

Application of Response Surface Optimization technique for Optimizing the Fin Size and Geometry of IC-Engine Air-Cooled Fins

¹Arvind Hota, ²Abhishek Shukla

¹: Student, Mechanical Engineering, Shri Shankaracharya Engineering College, Bhilai (M.Tech. Scholar)

²: Asst. Professor, Department of Mechanical Engineering, Shri Shankaracharya Technical Campus (Shri Shankaracharya Engineering College, Bhilai)

ABSTRACT

Due to improper heat dissipation in IC-engine cooling devices may lead to poor performance of IC-engines. To overcome the problem of improper heat dissipation in IC-engines, fins are used in cooling application for augmenting heat dissipation from engine surfaces to the atmosphere. Current research is based on the objective to conduct thermal analysis of IC-engine fins using Finite Element Analysis and to find out the effect of design parameters on heat dissipation by generating contours of temperature. The CAD model of IC engine fins is developed in ANSYS design modeler and response surface optimization technique is used for optimising the design parameters. The critical range of values of each design parameters are determined for which temperatures and heat flux are minimum or maximum. The sensitivity plot is also determined for each design parameter which shows the percentage and effect of each variable for output variables (temperature and heat flux). The results obtained from this work shows that the IC engines with rectangular fin shape is the most significant shape for enhancing heat dissipation rate. The Minimum Temperature obtained when flat rectangular IC-engine fins are used. And the results obtained by Response Surface Optimization shows that the Optimum Minimum Temperature is obtained at the flat rectangular IC-engine fins.

Keywords: Engine Fins, response surface optimization, Finite Element analysis

1. INTRODUCTION:

While working In an IC-engine, very high temperatures were attained as a result of burning of fuel in the engine; so it is necessary to lower the temperature of IC-engine by dissipating heat to the surrounding by means of external fins situated on the engine. IC-engine fins are used for heat dissipation from the engine to the surrounding. The heat dissipation takes place by means of Conduction and Convection. Conduction takes place from the inner surface of the combustion chamber of IC-engine to the fin surfaces and Convection takes place from the fin surfaces to the atmosphere. Hence, the cooling of engines thoroughly depends upon the shape and size of fins. The IC-engine fins may be of different shapes and sizes as per the requirement of the heat dissipation rate. In this research, fins of following types are considered for obtaining the best possible results of maximum heat dissipation viz. flat cylindrical fins, flat oval fins and flat rectangular fins. The modeling and analysis of fins are done using ANSYS.

2. LITERATURE REVIEW:

Sujan Shrestha, Nitesh Kumar Yadav and Suman Bikram Bam (2019) in their research states that their work is useful to recognize the better geometry and material for the fins for higher heat dissipation rate and engine cooling. In this research they had considered general materials like gray cast iron for engine block. The components are designed by using SOLIDWORKS and analysis is done by ANSYS. After simulation they found that the ANSYS value of heat flux = 151020 W/m² and the Obtained value of heat flux = 137428.2 W/m² and the percentage error = 9 %. Finally they concluded that Grey cast iron has low thermal conductivity hence the heat transfer rate is comparatively very low, considering other metals cast iron can withstand high temperatures & the cost is less compared. So it is mainly used in I. C Engine cylinder. [3]

Akash M Vyas, Ruchir Parikh and Dr. Umang Patdiwala (2018) conducted a study on improvement of heat transfer rate on various types of cooling fins by changing cylinder fin geometry. Aluminium is selected as a fin material for their analysis by ANSYS. They had created four Tetrahedral 3D model of circular Fin, rectangular fin, Serrated strip Fin and Serrated strip taper Fin having Static Temperature = 25 °C & Wind speed = 40 Km/hr as constants. From their research they concluded that the serrated strip fin geometry provide gives the effective solution. In their simulation they found that, minimum temperature distribution of serrated strip fin is 29 % less than the rectangular fin and 3.7 % less than the circular fin. By comparing simulation result for surface heat transfer, it is clearly observed that heat transfer enhancement can be performed using same cylinder with different fin profile. [4]

Vijayakumar P, Sathyamoorthy G and Velavan R (2017) in their research aim to enhance the performance of I.C engine, in order to change the fin materials and geometry. In this attempt they study and analyze the internal combustion engine fins for maximizing the performance by considering different geometrical profile, fin material, and variable fin length for weight reduction. Also an attempt has been made to decrease the engine heat transfer. They calculated the Heat transferred by the fins from Newton's formula, $Q_f(in) = \eta_f * A_s * h_{co} * (T_b - T_{\infty})$ Watts. Cast iron, Aluminum alloy, Alusil and Duralumin materials were taken into consideration for analysis. Fins are analyzed with different fin profiles, fin materials, variable fin profile and with minimal cooling conditions for an air cooled diesel engine of 5 HP. From the investigation, it is observed that Trapezoidal profile or Stepped rectangular

profile adoption will result in material saving and increases in performance. By using aluminum alloy as an alternative fin material for cast iron, performance of fins is increased about 7% with reduction in fin length is experienced, which in turn results in engine compactness and reduction in fin weight. [1]

Das et. Al. (2021) in their research had modelled different fins by using AUTODESK FUSION 360, and then meshing and post-processing were done using ANSYS WORKBENCH. The results (plots of temperature and heat flux distribution) obtained for various case studies had been analyzed and compared which showcased that the slotted circular fin geometry having higher fin thickness (3 mm) was the preferred fin geometry compared to other types of fin. They concluded that the Rectangular fin with 2 mm thickness with slot have higher heat transfer rate then with rectangular and cylindrical fins without slots of same thickness. [5]

Polidas Varalakshmi and M. Lavakumar (2015) in their research created a 3D parametric model of cylinder with Trapezoidal fin, Elliptical fin and Triangular fin bodies model in modeling software Pro/Engineer and analyzed the cylinder fins using LM13 material and also using AL356 which has 150 to 179W/m-K thermal conductivity. In this research, Steady state thermal analysis was done on the fins to determine Temperature Distribution, Total Heat flux and Directional Heat flux that are caused by thermal loads that do not vary over time. Analysis is conducted by varying material. The material used for the fin bodies are LM13 which has thermal conductivity of 0.28cal/cm²/0C at 250 c. [2]

Deepak Tekhre and Jagdeesh Saini (2017) in their research studied different literature surveys that how heat transfer through extended surfaces and the heat transfer coefficient affected by changing cross-section this study is useful to know the better geometry and material for the fins for better engine cooling. From their study they explore that there is huge scope of designing cooling fins for air cooled engines. This can improve heat dissipation from engine which can be achieved by changing fin geometry, fin material. Thermal analysis of cooling fin can easily be done by CFD on ANSYS while the model could be prepared on any modeling software like Creo. In which the thermal analysis of the super meshed model take place very accurately. This study also tells that CFD analysis is better than the theoretical analysis of the model. It also says that in present time Aluminium alloys like AL6061, 6063 are used at the large scale for the manufacturing of cooling fins of IC engines and they shows better thermal conductivity than the conventional steel alloys. From their detailed study of the papers they concluded that the geometry and cross section area of the fin is the most important criteria that decides the efficiency of the cooling fin. For increasing the cross section area making holes on the surfaces of fins also increases the heat rejection from fins faster than the plan rectangular fin. Increasing the hole size also improves the heat dissipation up to a limit as the hole size increases the minimum temperature on the fin gets reduced. Heat transfer coefficient depends on the time, space, flow condition and the fluid properties. They also founded that change in environmental condition causes great change in heat transfer coefficient and in its efficiency. [6]

Mukesh Kumar Singh and Prof. H. S. Sahu (2020) in their paper reviews the recent researches that were performed in heat sinks by considering various parameters and methods. They studied that the heat transfer effectiveness of fins with literature survey to identify the previous works that have been performed by mathematical, analytical and numerical methods with optimizing

profiles, materials and process parameters, this survey paper segmented and clustered the detail description of internal combustion engine fins. Slotted fins, Helical Fins, Rectangular Fins and a total 10 fins types were studied from different research papers with different investigation methods. They concluded that more improvements could be made by considering the materials like graphene and aluminum foam and Fins with different profiles of perforations should be used and would be analyzed for more improvement in heat transfer. Also Pin fins with slanted edge would be employed in heat sink which would increase the heat transfer rate because slanted edge have capability to converge the flow, due to this effective cooling would be done. [7]

Mulukuntla Vidya Sagar and Nalla Suresh (2017) in their research stated that they analyse the thermal properties like Directional Heat Flux, Total Heat Flux and Temperature Distribution by varying Geometry(Circular, Rectangular),material(Aluminium Alloy, Magnesium Alloy) and thickness of Fin (3mm,2mm) of an approximately square cylinder model prepared in SOLIDWORKS-2013 which is imported into ANSYS WORKBENCH-2016 for Transient Thermal analysis with an Average Internal Temperature and Stagnant Air-Simplified case as Cooling medium on Outer surface with reasonable Film Transfer Coefficient as Boundary Conditions. They concluded that by using circular fin with material Aluminium Alloy is better since heat transfer rate of the fin is more. By using circular fins the weight of the fin body reduces compared to existing rectangular engine cylinder fin. [9]

N. Ashokkumar et. al. (2016) in their research paper had performed a Steady state heat transfer finite element analyses using ANSYS Workbench™ Version 14.5, utilizing 3- D models and heat transfer material properties of current engine fins Assemblies. ANSYS results from modified fins Assembly designs are compared to baseline geometry ANSYS results. Baseline cooling analyses are performed to validate the FEA models. The baseline results show the average temperature at the inner surface of the heat during normal operating conditions is approximately 23°C above the maximum technical limit of 423K. The baseline results are considered acceptable based on the conservative boundary conditions used in the FEA model. Fins Stack Assemblies which utilize fin optimization varies of cross section with internal grooves like half circle, Triangular, Trapezoidal, Square cross section with sliding taper cut-out arrays are also analyzed. Then comparing constant natural materials to take AL 6061, AL 200, CE17, CE17M it's considering take thermal distribution analysis in transient conditions to solving problems it's defined. [8]

3. PROBLEM IDENTIFICATION:

3.1 Problem Identification: Improper heat dissipation in IC-engine cooling devices may lead to poor performance or premature failure. To overcome this problem, the fins are used in cooling application for augmenting heat dissipation from engine surfaces to the atmosphere. In this research, Air cooled fins are taken under consideration and three types of air cooled fins are analysed in ANSYS 2021 R1 and compared with each other so as to obtain the best possible results. Now to optimize the results obtained by thermal analysis of IC-engine fins; Surface Response Optimization is done in ANSYS 2021 R1.

3.2 Objective of the Result: The objective of this research to enhance the heat dissipation rate from the IC-engine to the surrounding through augmented fins using ANSYS 2021 R1 are as follows:

1. To conduct thermal analysis of IC-engine fins using FEA.
2. To investigate the effect of shape & size design parameter on heat dissipation by generating contours of Temperature.
3. To investigate the effect of shape & size design parameter on heat dissipation by generating contours of Total Heat Flux.
4. To optimize the obtained result by Surface Response Optimization using ANSYS.

4. METHODOLOGY:

4.1 Methodology of the research: The methodology of this research work can be easily understood with the help of the following flow chart:

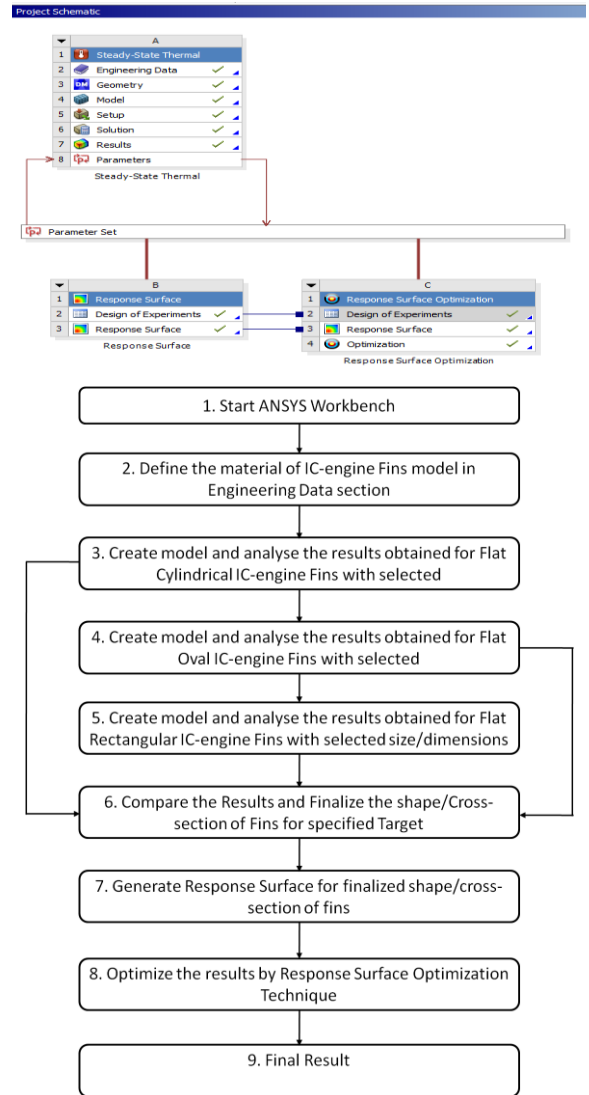

Figure 4.1: Methodology of the research

The structure, shape and size of the flat cylindrical fins are as follows:

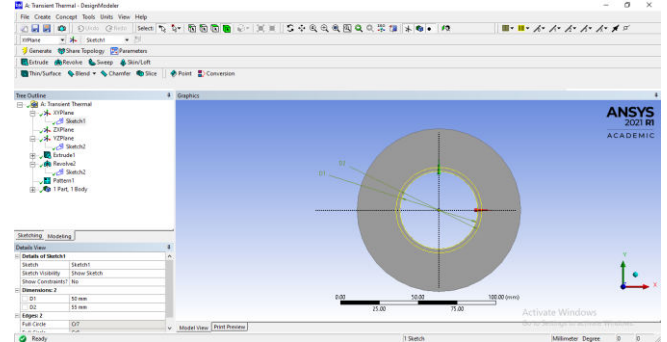

Figure 4.5 (a): Size of flat cylindrical fins

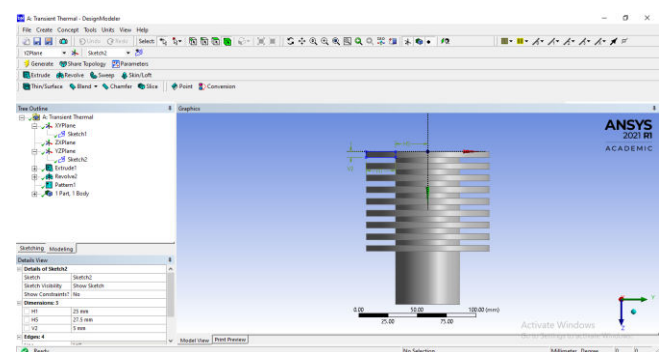

Figure 4.5 (b): Structure and shape of flat cylindrical fins

The structure, shape and size of the flat oval fins are as follows:

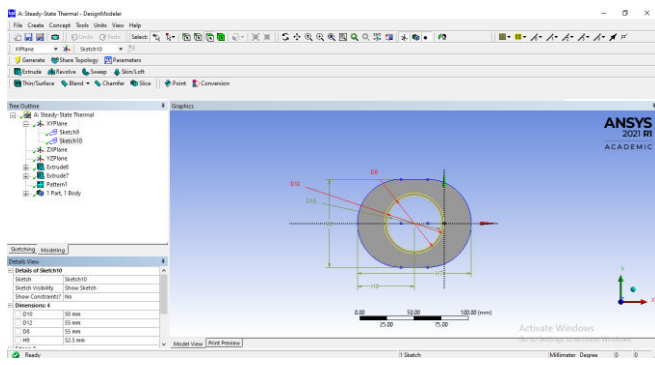

Figure 4.5 (c): Size of flat oval fins

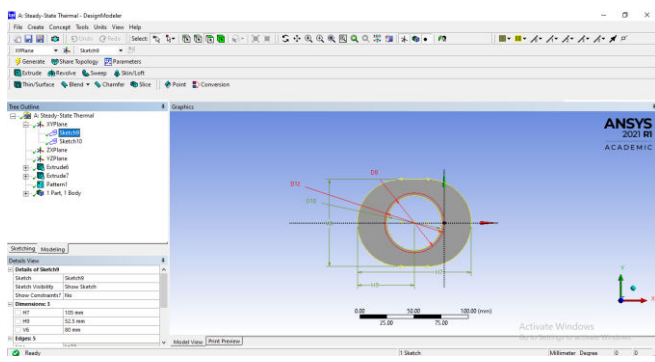

Figure 4.5 (d): Size of flat oval fins

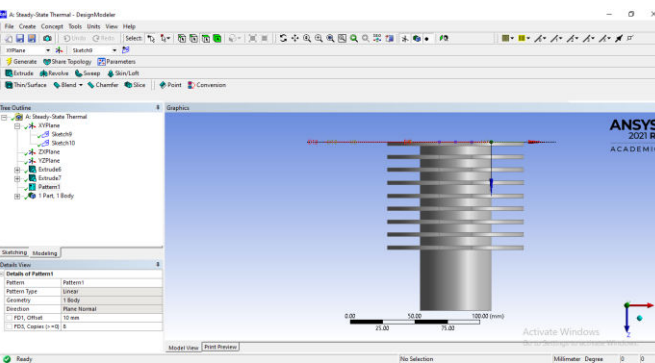

Figure 4.5 (e): Offset between flat oval fins

The structure, shape and size of the flat rectangular fins are as follows:

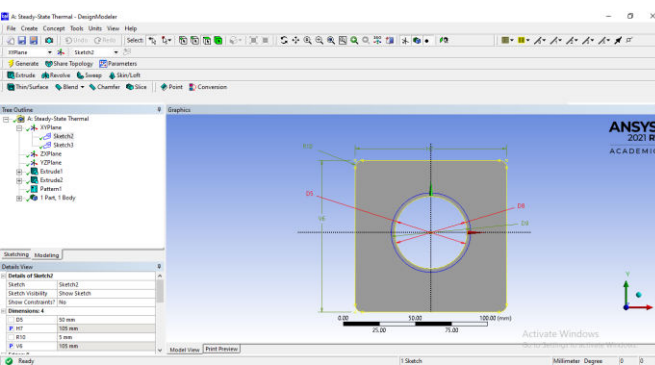

Figure 4.5 (f): Size of flat rectangular fins

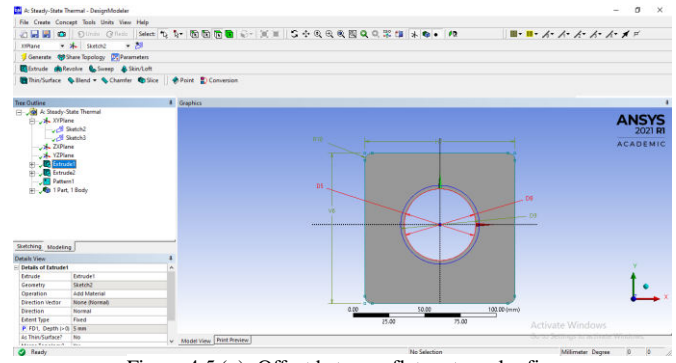

Figure 4.5 (g): Offset between flat rectangular fins

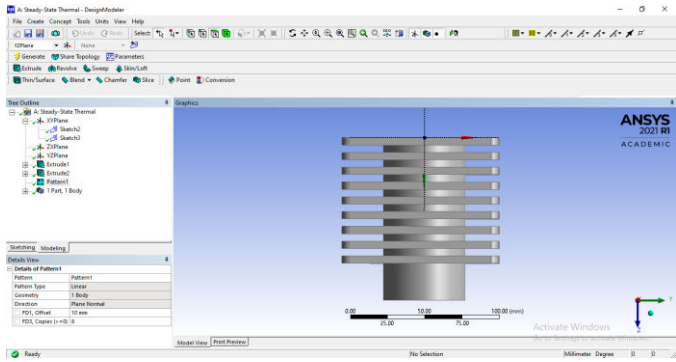

Figure 4.5 (h): Structure and shape of flat rectangular fins

5. RESULTS:

5.1 Steady State Thermal Analysis of IC-engine fins:

The steady state thermal analysis of IC-engine fins for air cooled engines is done in ANSYS 2021 R1 to find out the temperature distribution and total heat flux distribution from the engine to the surrounding through augmented fins of three types viz. flat cylindrical fins, flat oval fins and flat rectangular fins.

The steady state thermal analysis of flat cylindrical fins of air cooled IC-engines:

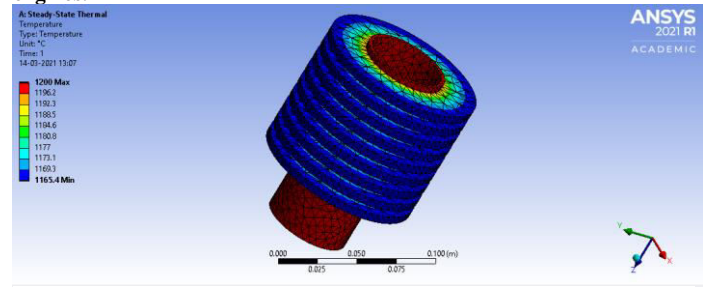

Figure 5.1: Temperature distribution plot of flat cylindrical fins of an air cooled IC-engines

From figure 5.1 the maximum temperature of 1200 °C is applied at the surface of the combustion chamber of an air cooled IC-engine represented by red colour and the minimum temperature of 1165.4 °C is obtained at the end surface of flat cylindrical fins represented by blue colour. The temperature varies from maximum to minimum in between the surface of combustion chamber of engine to end surface of fins.

The steady state thermal analysis of flat oval fins of air cooled IC-engines:

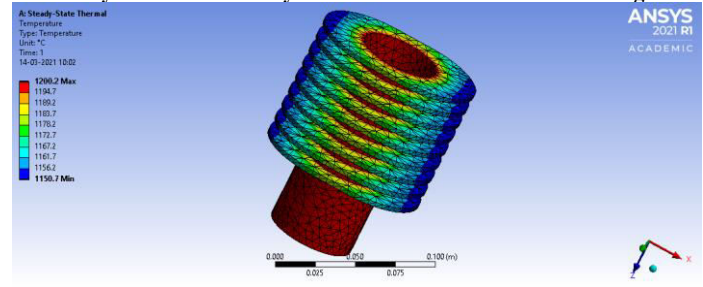

Figure 5.2: Temperature distribution plot of flat oval fins of an air cooled IC-engines

From figure 5.2 the maximum temperature of 1200.2 ° C is obtained at the surface of the combustion chamber of an air cooled IC-engine represented by red colour and the minimum temperature of 1150.7 ° C is obtained at the end surface of flat oval fins in major axis represented by blue colour and temperature of 1178.2 ° C is obtained at the end surface of flat oval fins in minor axis represented by light green colour. The temperature varies from maximum to minimum in between the surface of combustion chamber of engine to end surface of fins.

The steady state thermal analysis of flat rectangular fins of air cooled IC-engines:

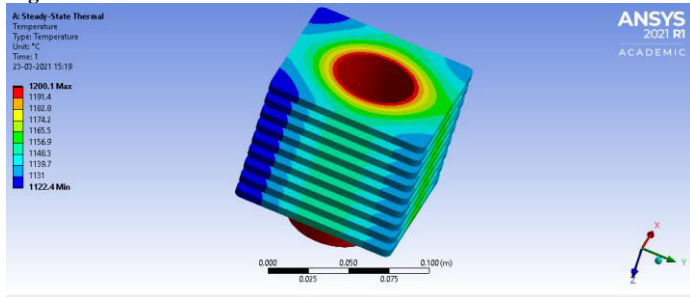

Figure 5.3: Temperature distribution plot of flat rectangular fins of an air cooled IC-engines

From figure 5.3 the maximum temperature of 1200.1 ° C is obtained at the surface of the combustion chamber of an air cooled IC-engine represented by red colour and the minimum temperature of 1122.4 ° C is obtained at the corners of flat rectangular fins represented by blue colour. The temperature varies from maximum to minimum in between the surface of combustion chamber of engine to corners of fins along the surface.

Maximum and Minimum temperature and total heat flux of the three types of fin is as following:

Table 5.4: Minimum and Maximum Temperature and Total Heat Flux of three types of fins:

Fin Type	No. of Fins used	Width of Fin	Thickness of Fin	Offset distance between Fins	Temperature (in ° C)	
					Min.	Max.
Flat Cylindrical Fin	9	25 mm dia.	5 mm	10 mm	1165.4	1200
Flat Oval Fin	9	25 mm dia. (max.)	5 mm	10 mm	1150.7	1200.2
Flat Rectangular Fin	9	25 mm	5 mm	10 mm	1122.4	1200.1

From the above Table 5.4; considering same number of fins, same width of fins, same thickness of fins and same offset distance between fins; following results were obtained:

1. The shape or cross-section of fin used for maximum heat dissipation should be flat rectangular fin type.
2. The minimum and maximum temperatures obtained at flat rectangular fin are 1122.4 ° C and 1200.1 ° C respectively.

Now, Response Surface is generated for flat rectangular IC-engine fins to determine the response surface and sensitivity of the output parameters. For this; Design of Experiments is done and following values are obtained from ANSYS:

Table 5.5: Tabulated data of Design of Experiments

Table of Schematic B2: Design of Experiments (Central Composite Design 1 Auto Defined)						
A	B	C	D	E	F	
Name	P1 - FinLength (mm)	P2 - FinWidth (mm)	P3 - FinThickness (mm)	P4 - Temperature Minimum (C)	P5 - Temperature Maximum (C)	
1	105	105	5	1122.4	1200.1	
2	105	105	5	1122.4	1200.1	
3	105	105	5	1097.6	1200.1	
4	105	105	5	1123	1200.1	
5	105	105	5	1108.8	1200.1	
6	105	105	5	1115.8	1200.1	
7	105	105	5	1127.8	1200.1	
8	96.463	96.463	4.5935	1118.3	1200.1	
9	113.54	96.463	4.5935	1097.2	1200.1	
10	96.463	113.54	4.5935	1108.8	1200.1	
11	113.54	113.54	4.5935	1087.2	1200.1	
12	96.463	96.463	5.4065	1127.9	1200.1	
13	113.54	96.463	5.4065	1109.4	1200.1	
14	96.463	113.54	5.4065	1119.6	1200.1	
15	113.54	113.54	5.4065	1100.6	1200.1	

Table 5.5 shows the generated tabulated data of design of experiments in ANSYS. In this data, 15 points were generated for four output parameters with three input parameters.

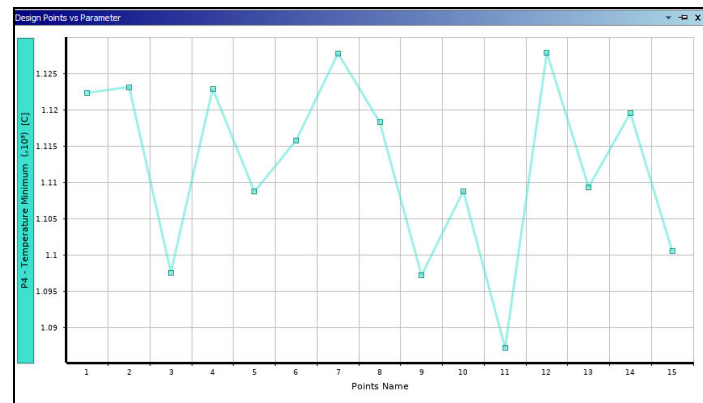

Figure 5.4: Design Points Vs. Parameter chart for Minimum Temperature

Above figure shows the Chart between design points Vs. Minimum temperature output parameter. The minimum temperature is obtained at design point 11.

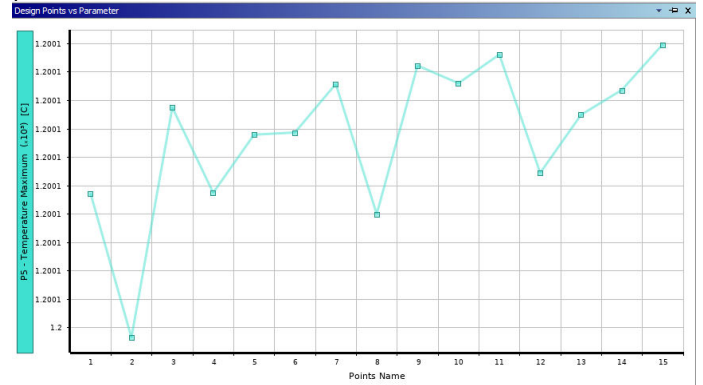

Figure 5.5: Design Points Vs. Parameter chart for Maximum Temperature

Above figure shows the Chart between design points Vs. Maximum temperature output parameter. The maximum temperature is obtained at design point 15.

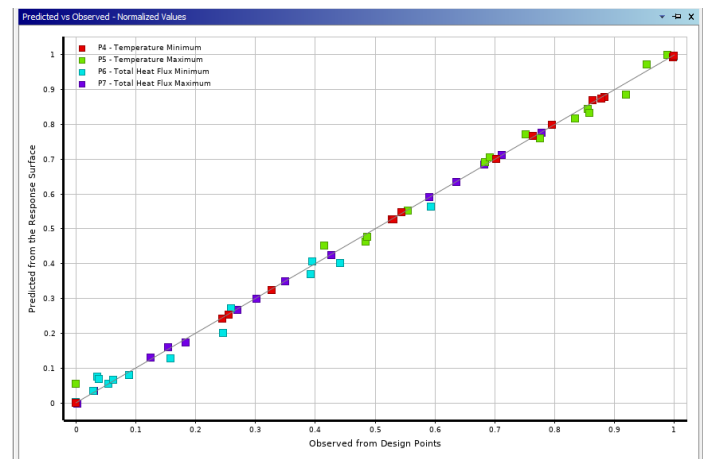

Figure 5.6: Goodness of Fit of Design of Experiment

Above figure shows the Goodness of Fit of Design of Experiment by ANSYS. The figure shows that maximum points were good enough.

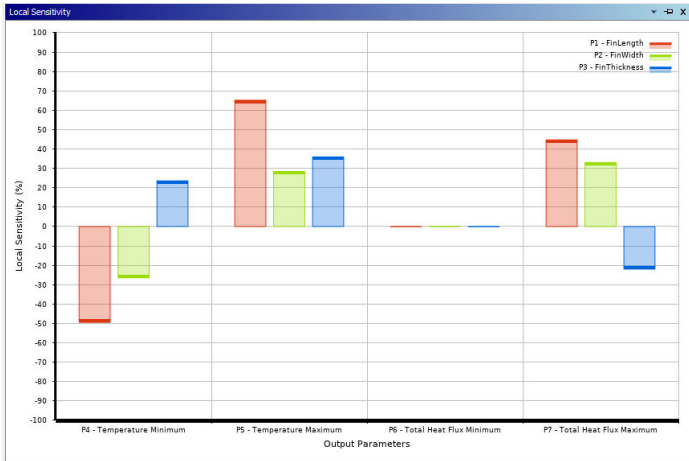

Figure 5.7: Local Sensitivity Bar Chart of Design of Experiments

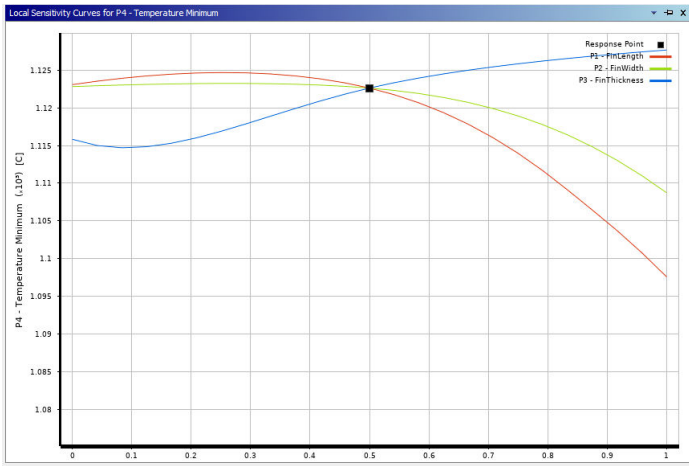

Figure 5.8: Local Sensitivity Curves of Design of Experiments

Now, Response Surface is generated by applying Response Surface to the flat rectangular IC-engine fins. The results generated by applying Response Surface to the flat rectangular IC-engine fins to obtain minimum temperature from the IC-engine combustion chamber to the fins are as follows:

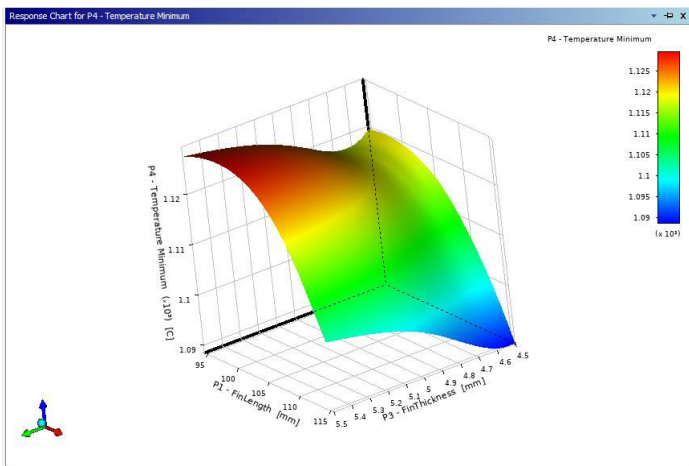

Figure 5.9: Response Surface (Fin Thickness Vs. Fin Length Vs. Minimum Temperature)

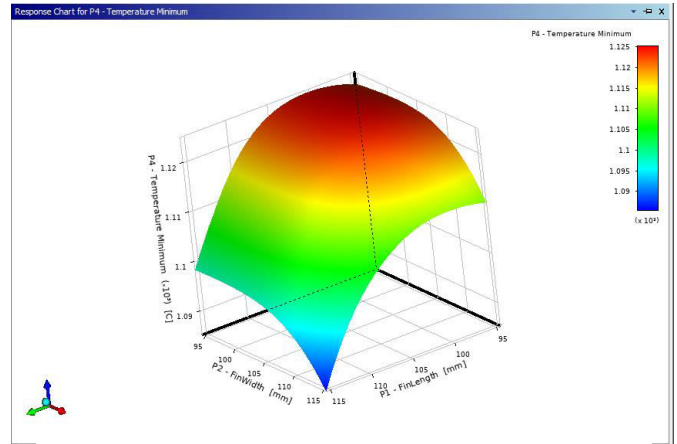

Figure 5.10: Response Surface (Fin Width Vs. Fin Length Vs. Minimum Temperature)

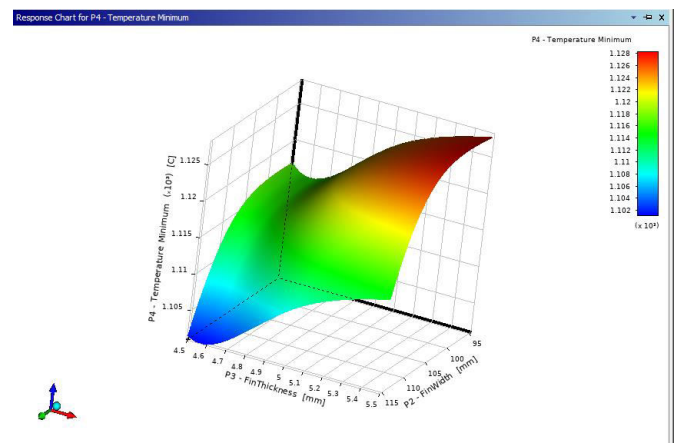

Figure 5.11: Response Surface (Fin Width Vs. Fin Thickness Vs. Minimum Temperature)

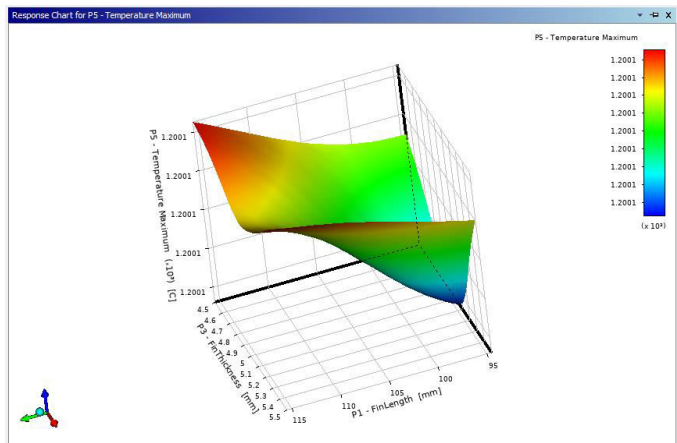

Figure 5.12: Response Surface (Fin Thickness Vs. Fin Length Vs. Maximum Temperature)

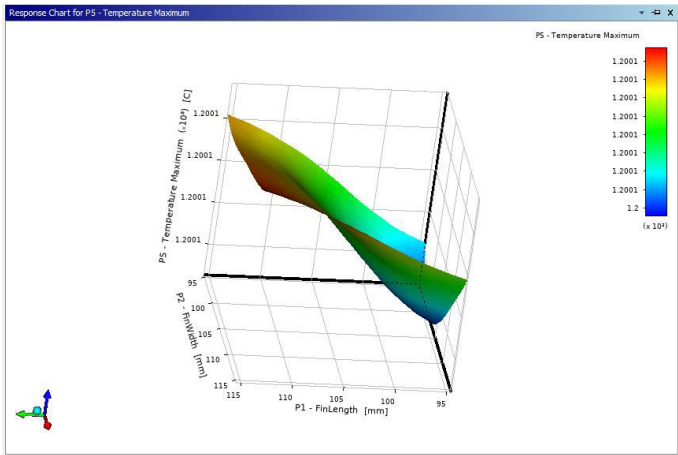

Figure 5.13: Response Surface (Fin Width Vs. Fin Length Vs. Maximum Temperature)

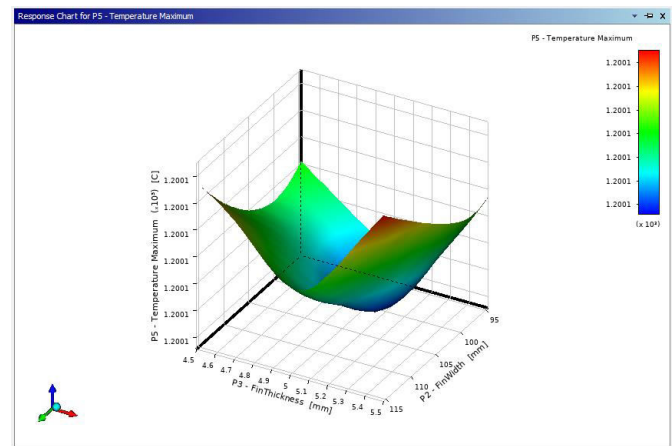

Figure 5.14: Response Surface (Fin Width Vs. Fin Thickness Vs. Maximum Temperature)

Now, Response Surface Optimization to obtain optimum minimum temperature in fins is done to optimize the results obtained by applying response surface to flat rectangular IC-engine fins.

Table 5.6: Candidate Points obtained by Response Surface Optimization

A	B	C	D	E	F	G	H
Reference	Name	P1 - FinLength (mm)	P2 - FinWidth (mm)	P3 - FinThickness (mm)	P4 - Temperature Minimum (C)	Parameter Value	P5 - Temperature Maximum (C)
1	Reference	115.48	115.49	4.5115	1075.2	-0.01%	1200.1
2	Candidate Point 1	115.5	115.46	4.537	1075.2	-0.01%	1200.1
3	Candidate Point 2	115.5	115.41	4.5186	1075.3	0.00%	1200.1
4	Candidate Point 3	115.5	115.41	4.5186	1075.3	0.00%	1200.1
5	my	105	105	5	1122.6	4.40%	1200.1
6	my (EvenFeet)	105	105	5	1122.4	4.38%	1200.1

Form the above table 5.6, the best candidate point obtained is Candidate Point 3 because there is no variation or 0 % variation from reference data. Hence Following result is obtained from the above table 5.6:

- Optimized Fin Length of Flat Rectangular Fins = 115.5 mm
- Optimized Fin Width of Flat Rectangular Fins = 115.41 mm
- Optimized Fin Thickness of Flat Rectangular Fins = 4.5186 mm
- Minimum Temperature = 1075.3 °C
- Maximum Temperature = 1200.1 °C

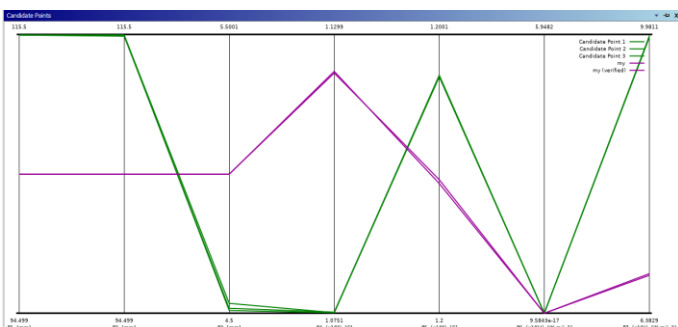

Figure 5.15: Candidate Point chart obtained from Response Surface optimization

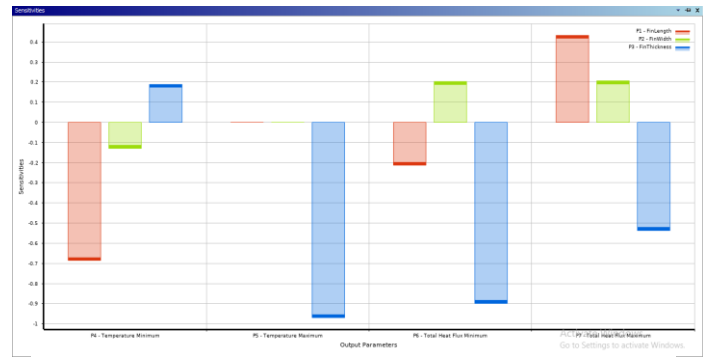

Figure 5.16: Sensitivity Chart generated by Response Surface Optimization

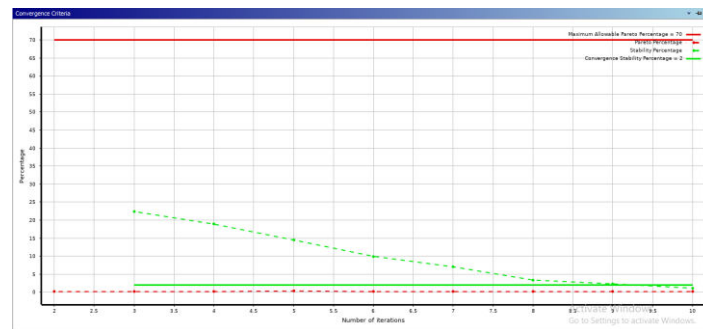

Figure 5.17: Convergence Criteria Chart generated by Response Surface Optimization

6. REFERENCES:

- Vijaykumar P, S. G. (2017). Experimental Analysis of Fins to Enhance the Performance of I.C Engines. *Journal of Chemical and Pharmaceutical Sciences* , 381-385.
- Polidas Varalakshmi, M. L. (2015). Steady State Thermal Analysis of Engine Cylinder Fin by Changing Geometry and Material. *International Journal & Magazine of Engineering, Technology, Management and Research* , 1605-1612.
- Sujan Shrestha, N. K. (2019). ANALYSIS OF HEAT TRANSFER THROUGH FINS OF IC ENGINE. *ResearchGate* , 1-11.
- Akash M Vyas, R. P. (2018). Analysis of I.C. Engine Fins for Effective Cooling Performance. *IJSTE - International Journal of Science Technology & Engineering* , 5 (1), 16-21.
- A. N. Mohan Das et. al. (2021). Transient thermal analysis of different types of IC engine cylinder fins by varying thickness and introducing slots. *Journal of Mechanical Engineering Research* , 12 (1), 1-18.
- Deepak Tekhre, J. S. (2017). Design Modification and Thermal Analysis of IC Engine Fin – A Review. *IJIRST –International Journal for Innovative Research in Science & Technology* , 4 (1), 57-60.
- Mukesh Kumar Singh, P. H. (2020). A Review on Internal Combustion Engine Fins. *International Journal of Engineering Research & Technology (IJERT)* , 9 (08), 802-804.
- N.Ashokkumar et. al. (2016). Design and Analysis of Engine Fins. *International Journal of Innovative Research and Creative Technology* , 2 (2), 34-39.
- Mulukuntla Vidya Sagar, N. S. (2017). Thermal Analysis of Engine Cylinder with Fins by using ANSYS Workbench. *International Journal of Engineering Research & Technology (IJERT)* , 6 (06).
- Sanjay Kumar Sharma and Vikas Sharma: “Maximizing The Heat Transfer Through Fins Using CFD As A Tool.” *International Journal of Recent advances in Mechanical Engineering (IJMECH)* Vol.2, No.3, August 2013.

11. Prof. Arvind S. Sorathiya, Hiren P. Hirpara, Prof. Dr. P.P. Rathod: "An Effect of Different Parameters of Fins on Heat Transfer of IC Engine." *IOSR Journal of Mechanical and Civil Engineering (IOSR-JMCE)*, Volume 11, Issue 3 Ver. I (May-Jun. 2014).
12. HongbinYan, ShangshengFeng, TianjianLu, GongnanXie: "Experimental and numerical study of turbulent flow and enhanced heat transfer by cross-drilled holes in a pin-finned brake disc." *International Journal of Thermal Sciences* 118 (2017) 355-366.
13. Prof. Arvind S. Sorathiya, Manankumar B. Joshi, Prof. (Dr.) Pravin P. Rathod: "Heat Transfer Augmentation of Air Cooled 4 stroke SI Engine through Fins." *IJREAT International Journal of Recent advances in Engineering & Advanced Technology*, Volume 2, Issue 1, Feb-Mar, 2014.
14. Mohsin A. Ali and Prof. (Dr.) S.M Kherde: "Design Modification and Analysis of Two Wheeler Engine Cooling Fins by CFD." *International Journal of Science, Engineering and Technology Research (IJSETR)*, Volume 4, Issue 2, February 2015.
15. Abhishek Mote, Akshay Choukse, Atharva Godbole, Dr. Pradeep Patil, Avinash Kumar Namdeo: "Analysis of Heat transfer through fins of an IC Engine using CFD." *International Research Journal of Engineering and Technology (IRJET)*, Volume: 03, Issue: 04, Apr-2016.
16. Sanjay Kumar Sharma and Vikas Sharma: "Maximizing The Heat Transfer Through Fins Using CFD As A Tool." *International Journal of Recent advances in Mechanical Engineering (IJMECH)* Vol.2, No.3, August 2013.