

Intelligent Water Quality and Water Supply Management System for Smart City using PIC

Mr.R.N.Kadu¹, Priya Bargal², Pratiksha Bobade³, Komal Wani⁴

¹Prof. Dept. of Electronics and Telecommunication Engineering, Pravara Rural Engineering college, Loni, India

^{2,3,4}Students, Dept. of Electronics and Telecommunication Engineering, Pravara Rural Engineering college, Loni, India

Abstract - During the past decade, water needs have increased unpredictably in India. Increasing demand of water supply has become a major challenge for the world. Wasteful usage of water, climatic changes and Urbanization has further depleted the resource. Conservation and management of the resource must be given utmost importance. In this paper, we present an IoT design for water monitoring and control approach which supports internet based data collection on real time bases. The system addresses new challenges in the water sector -flow rate measuring and the need for a study of the supply of water in order to curb water wastage and encourage its conservation. We also measure the quality of water distributed to every household by deploying pH and conductivity sensors. The traditional water metering systems require periodic human intervention for maintenance making it inconvenient and often least effective. For shortcoming of the existing models of ubiquitous usage of wireless systems for smart quality monitoring we communicate data wirelessly.

Key Words: Water Quality Detection, IOT web server, Water Supply Management, PH Sensor, RTC.

1. INTRODUCTION

Water is an important resource for all the livings on the earth. In that, some people are not getting sufficient amount of water because of unequal distribution. We can use this approach so that everyone gets the equal amount of water. It is also used to avoid the wastage of water during the distribution period. In the previous method, the employee will go to that place and open the valve for a particular duration, then again the employee will go to the same place and close the valve, it is waste of time. The proposed system is fully automated. Here human work and time are saved. To ensure the safe supply of drinking water the quality should be monitored in real time for that purpose new approach IOT (Internet of Things) based water quality monitoring has been proposed. In this project, we will implement the design of IOT base water quality monitoring system that monitors the quality of water in real time. This system consists some sensors which measure the water quality parameter. The real-time monitoring of water resources information will benefit the water resources management department and the public. The primary concept of real-time IOT based water resources information system is to provide comprehensive and accurate information. The system is developed through defining some explicit water resource parameters then, Water level and flow parameter are defined for water measure & management, followed by a

sensor network for water resources information monitoring is constructed based on IOT.

Water quality is affected by both point and non-point sources of pollution, which include sewage discharge, discharge from industries, run-off from agricultural fields and urban run-off. Other sources of water contamination include floods and droughts and due to lack of awareness and education among users. The need for user involvement in maintaining water quality and looking at other aspects like hygiene, environment sanitation, storage and disposal are critical elements to maintain the quality of water resources.

1.2. LITERATURE REVIEW

[1] **Intelligent Water System for Smart Cities Hitachi Review Vol. 61 (2014), Fumio Mizuki Kazuhiro Mikawa, Dr. Eng. Hiromitsu Kurisu**, Japan is rich in water resources with little experience of water shortages. Internationally, however, examples can be seen both of locations where lack of water is a physical phenomenon and where it is an economic one, and it is predicted that water shortages will become more severe as populations rise and become more concentrated in the urban areas. Effective ways of supplying water to afflicted cities include production of water by seawater desalination and use of recycled water, and there is a need to manage the overall circulation of water around the city efficiently. To provide smart cities with water infrastructure systems, Hitachi is promoting its intelligent water system concept for integrating water treatment systems with information and control systems for the efficient utilization of recycled water.

[2] **Intelligent Water Quality and Water Supply Management System for Smart City using ARM Mr.D. B Rane¹, Shital Ghuge², Payal Chaudhari ³, Pooja Tejimkar⁴**, During the past decade, water needs have increased unpredictably in India. Increasing demand of water supply has become a major challenge for the world. Wasteful usage of water, climatic changes and Urbanization has further depleted the resource. Conservation and management of the resource must be given utmost importance. In this paper, we present an IoT design for water monitoring and control approach which supports internet-based data collection on real time bases. The system addresses new challenges in the water sector -flow rate measuring and the need for a study of the supply of water in order to curb water wastage and encourage its conservation. We also measure the quality of water distributed to every household by deploying pH and

conductivity sensors. The traditional water metering systems require periodic human intervention for maintenance making it inconvenient and often least effective. For shortcoming of the existing models for a ubiquitous usage of wireless systems for smart quality monitoring and communicate data wirelessly.

[3]Jayti Bhatt,Jignesh Patoliya entitled “Real Time Water Quality Monitoring System”. This paper describes to ensure the safe supply of drinking water the quality should be monitored in real time for that purpose new approach IOT (Internet of Things) based water quality monitoring has been proposed. In this paper, we present the design of IOT based water quality monitoring system that monitor the quality of water in real time. This system consists some sensors which measure the water quality parameter such as pH, turbidity, conductivity, dissolved oxygen, temperature. The measured values from the sensors are processed by microcontroller and these processed values are transmitted remotely to the core controller that is raspberry pi using Zigbee protocol. Finally, sensors data can view on internet browser application using cloud computing.

2. PROPOSED SYSTEM

To ensure the safe supply of drinking water the quality should be monitored in real time for that purpose new approach IOT (internet of thing) based water quality monitoring has been proposed .in this project; we will implement the design of IOT base water quality monitoring system that monitors the quality of water in real time. This system consist some sensor which measure the water quality parameter.

The real time monitoring of water resource information will benefit the water resource information will benefit the water resource management department and the public. The primary concept of real time IOT based water resource information system is to provide comprehensive and accurate information.

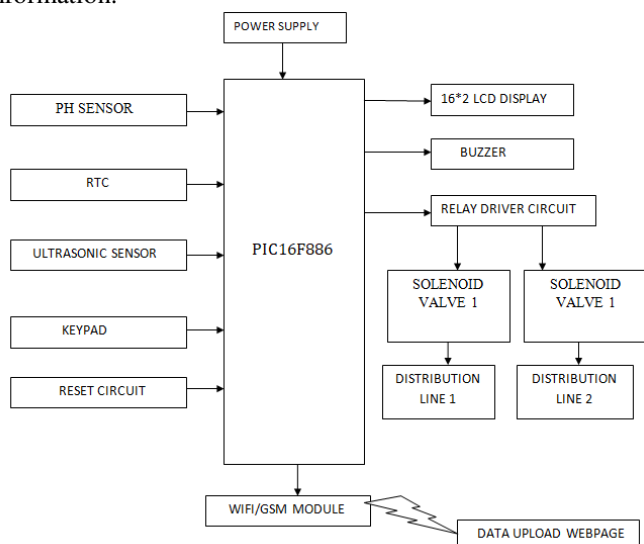

Fig -1: Block Diagram

2.1 PIC 16F886 MICROCONTROLLER:

This powerful yet easy-to-program (only 35 single word instructions) CMOS FLASH-based 8-bit microcontroller packs Microchip's powerful PIC® architecture into a 28 pin package. The PIC16F886 features 256 bytes of EEPROM data memory, self-programming, an ICD, 2 Comparators, 11 channels of 10-bit Analog-to-Digital (A/D) converter, 1 capture/compare/PWM and 1 Enhanced capture/compare/PWM functions, a synchronous serial port that can be configured as either 3-wire Serial Peripheral Interface (SPI™) or the 2-wire Inter-Integrated Circuit (I²C™) bus and an Enhanced Universal Asynchronous Receiver Transmitter (EUSART). All of these features make it ideal for more advanced level A/D applications in automotive, industrial, appliances or consumer applications.



Fig -2: PIC16F886

2.2 Ultrasonic Sensor:

The ultrasonic sensor is success is due to its high reliability. Versatile in for object detection and level measurement, these sensors operate with extreme precision due to their high reliable sound wave technology. Ultrasonic HC-SR04 is an ultrasonic ranging module that provides 2 cm to 400 cm non-contact measurement function. The ranging accuracy can reach to 3mm and effectual angle is $< 15^0$ It can be powered from a 5V power supply. The HC-SR04 ultrasonic sensor uses SONAR to determine the distance of an object just like the bats do. It offers excellent non-contact range detection with high accuracy and stable readings in an easy-to-use package from 2 cm to 400 cm or 1” to 13 feet.



Fig -3: Ultrasonic Sensor

2.3 Relay Driver Circuit:

A relay driver circuit is a circuit which can drive, or operate, a relay so that it can function appropriately in a circuit. The driven relay can then operate as a switch in the circuit which can open or close, according to the needs of the circuit and its operation. Since DC and AC voltages operate differently, to build relay drivers for them requires slightly different setup. We will also go over a generic relay driver which can operate from either AC or DC voltage and operate both AC and DC relays. Now that we're using a transistor to drive the relay, we can use considerably less power to get the relay driven. Because a transistor is an amplifier, we just have to make sure that the base lead gets enough current to cause a larger current to flow from the emitter of the transistor to the collector. Once the base receives sufficient power, the transistor will conduct from emitter to collector and power the relay.

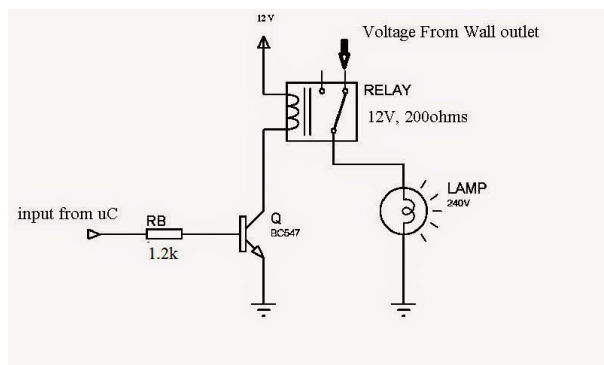

Fig -4: Relay Driver Circuit

2.4. GSM module:

This GSM modem has a SIM800A chip and RS232 interface while enables easy connection with the computer or laptop using the USB to Serial connector or to the microcontroller using the RS232 to TTL converter. Once you connect the SIM800 modem using the USB to RS232 connector, you need to find the correct COM port from the Device Manger of the USB to Serial Adapter. Then you can open Putty or any other terminal software and open a connection to that COM port at 9600 baud rate, which is the default baud rate of this modem. Once a serial connection is open through the computer or your microcontroller you can start sending the AT commands.



Fig -5: GSM Module

2.5. LCD display:

A 16x2 LCD means it can display 16 characters per line and there are 2 such lines. In this LCD each character is displayed in 5x7 pixel matrix. This LCD has two registers, namely, Command and Data. The command register stores the command instructions given to the LCD. A command is an instruction given to LCD to do a predefined task like initializing it, clearing its screen, setting the cursor position, controlling display etc. The data register stores the data to be displayed on the LCD.

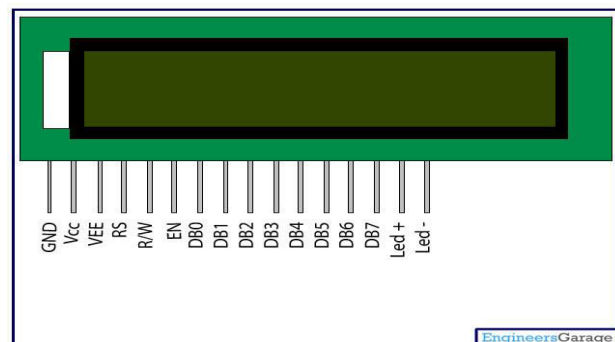

Fig -6: LCD Display

2.6. PH Sensor:

In PH SENSOR Here comes an analog pH meter, specially designed for Arduino controllers and has built-in simple, convenient and practical connection and features. It has an LED which works as the Power Indicator, a BNC connector and PH2.0 sensor interface. You can just connect the pH sensor with BNC connector, and plug the PH2.0 interface into any analog input on Arduino controller to read pH value easily.



Fig -7: PH Sensor

2.7. RTC PCF8563:

There is so many Real Time Clock (RTC) Module available in the market like DS1307 & DS3231. But when it comes to power consumption, their power consumption is a little higher which can drain the battery quickly in case if we are going with battery-powered device applications. So a Real time clock module whose power consumption is extremely less is PCF8563 Module. This module is also an I2C module.

The PCF8563 is a CMOS Real-Time Clock (RTC) and calendar optimized for low power consumption. A programmable clock output, interrupt output, and a voltage-low detector is also provided. All addresses and data are transferred serially via a two-line bidirectional PC-bus. The maximum bus speed is 400 kbit/s.

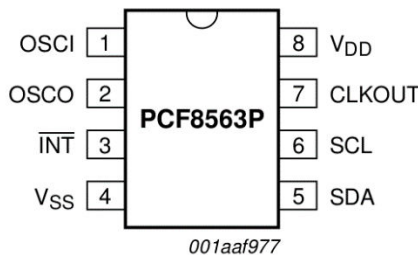

Fig -8: RTC

2.6. IOT:

“The Internet of Things (IoT) is a system of interrelated computing devices, mechanical and digital machines, objects, animals or people that are provided with unique identifiers and the ability to transfer data over a network without requiring human-to-human or human-to-computer interaction.”

Things are either sensors or actuators. A sensor is something that tells us about our environment. Think of a temperature sensor, or even the GPS receiver on your mobile phone. Actuators are something that you want to control, things like thermostats, lights, pumps, and outlets. The “Internet of Things” brings everything together and allows us to interact with our things. For example, you could have your thermostat control itself based on where you’re located.

2.7. Things Speak Basics:

ThingSpeak is an application platform for the Internet of Things. ThingSpeak allows you to build an application around data collected by sensors. Features of ThingSpeak include real-time data collection, data processing, visualizations, apps, and plugins.

At the heart of ThingSpeak is a ThingSpeak Channel. A channel is where you send your data to be stored. Each channel includes 8 fields for any type of data, 3 location fields, and 1 status field. Once you have a ThingSpeak Channel you can publish data to the channel, have ThingSpeak process the data, and then have your application retrieve the data.

3. RESULT:

Here we successfully implemented “Intelligent Water Quality & Water Supply Management System for Smart City”. We successfully measure PH of water. And distribute water according to real time clock. Also we successfully upload data over IOT. Following Pictures shown our actual hardware and IOT web page.

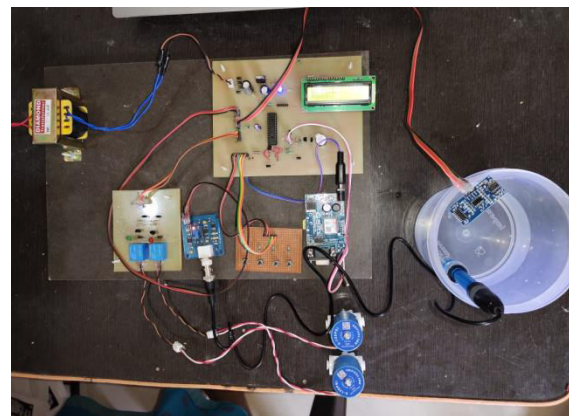

Fig -9: hardware of System

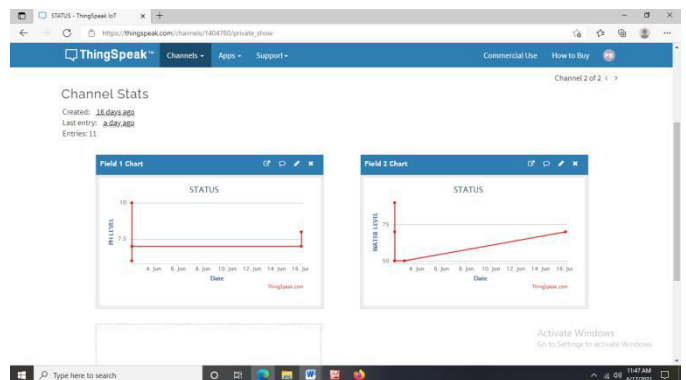

Fig -10: IoT web page

4. CONCLUSIONS

Using this system secure and continuous monitoring is possible no need. To go on field for monitoring so manual work has reduced it makes system more efficient, reliable, low cost and accurate we can Data monitored from anywhere controlling is possible from a remote server it is Economical in development.

Here we successfully implemented “Intelligent Water Quality & Water Supply Management System for Smart City”. We make actual prototype model of this system. This system consists of PIC18F886 as controller which gets input from different sensors to check water quality and level. All parameter are display on LCD display and send that parameter over IOT using GSM module.

ACKNOWLEDGEMENT

We take this opportunity to thank our project guide, Mr. R.N. Kadu for his guidance and support throughout the course duration. His efforts to clear our concepts and to help us code the entire algorithm were valuable for the development of this project. His role as a project Guide helped us to meet all our deadlines.

REFERENCES

[1]Baum-Haley, Melissa et al. (2014, March). Landscape Irrigation Best Management Practices. Fall Church, VA: Irrigation Association and American Society of Irrigation Consultants. Retrieved from www.nciclb.org/wp-content/uploads/2017/08/Best-Management-Practices.pdf.

[2]Bill Gauley, P.Eng., Principal, Gauley Associates Ltd. (2017, February). Water Savings and Financial Benefits Associated with SingleFamily Package Graywater Systems. Chicago, IL: Alliance for Water Efficiency. Retrieved from .

[3]Crook, James. (2004). Innovative Applications in Water Reuse: Ten Case Studies. Boston, MA: WaterReuse Association. Retrieved from watereuse.org/wp-content/uploads/2015/10/WRA-101.pdf.

[4]Crook, James. (2007). Innovative Applications in Water Reuse and Desalination Case Studies 2. Alexandria, VA: WaterReuse Association (WRA). Retrieved from watereuse.org/wpcontent/uploads/2015/10/WRA-103.pdf.

[5]Environmental Working Group (EWG) &Northeastern University Social Science Environmental Health Research Institute (SSEHRI). (2017, June). Mapping a Contamination Crisis: Toxic fluorinated chemicals in tap water and at industrial or military sites. Retrieved from www.ewg.org/interactivemaps/2017_pfa/index.php.

[6] Jing M, “The design of wireless remote monitoring system of water supply based on GPRS”, IEEE International Symposium on Computer Science and Society (ISCCS), (2011), pp.29-31.