

## REVIEW PAPER ON ROBOT FOR HOSPITAL

Neelu Singh <sup>\*1</sup>, Pravin Matlane <sup>\*2</sup>, Divya Bawankar <sup>\*3</sup>, Nehal Borkar <sup>\*4</sup>, Krunali Rarokar <sup>\*5</sup>,  
Prof. Pankaj Shende <sup>\*6</sup>

Department of Electronics Engineering, K. D. K. College of Engineering Nagpur, Maharashtra, India.

### ABSTRACT

*As the hospital are facing so many issues, the hospital robots allows the patients to experience the impact of robot technology but also benefits the hospital by reducing the risk of infection. This project describes in hospital how to control a robot using mobile through Bluetooth communication, some features about Bluetooth technology, components of the mobile and robot. We present a review of robots controlled by mobile phone via moving the robot upward, backward, left and right side by the android application such as Arduino, Bluetooth. We are using Arduino software to interface the module of Bluetooth. According to commands received from android phone the robot motion can be controlled. We derived easy solutions to provide a framework for hospital robots with very low cost but with computation and sensing capabilities provided by the android phone that is used as a control device. This robot perform many task and multifunctional that's why it can be referred as one man army.*

**Keywords:** Arduino Uno, multifunctional, COVID-19, UV-disinfection, Bluetooth communication

### I. INTRODUCTION

In this world, the healthcare industry is facing considerable pressure to improve accessibility, efficiency and cost structures while striving to sustain the quality of health service delivery and

many more things. Providing healthcare to a rapidly aging population while using few resources has

become a key challenge of this century in industrialized countries. As COVID-19 spreads all over the worlds, hospitals are in very bad condition, Surfaces contaminated with viruses. Thus, policy-makers and citizens have high expectations that technology innovations might solve or at least minimize aspects of this problems.

To minimize the risks and to support COVID-19 fights we have designed a UV light cleaner & multifunctional robot which performs different operations they are floor cleaning, hand sanitizer and food delivery which is very helpful to the hospital and small clinic. The project aims to designing a Robot that can be operated using Android mobile phone. The controlling of the Robot is done wireless through smart phone using the Bluetooth feature present in it. Here in the project the smart phone is used as a remote control for operating the Robot. The controlling device of all the system is a Arduino Uno. In achieving the multi task the controller is loaded with a program written using 'C++' language.

### II. EXISTING WORK

#### 1. Android application based Bluetooth controlled robotic car[1]

A journal on "android application based Bluetooth controlled robotic car" researched by Ayan Maity, Avijit Paul, Priyanka Goswami, Ankan Bhattacharya published on International Journal of Intelligent Information Systems in 2017 showed a detail about android application based bluetooth robotic car with short and clear view writing. This project describes how to control a robot using mobile through Bluetooth communication, some features about Bluetooth technology, components of the mobile and robot. They present a review of robots controlled by mobile phone via moving the robot upward,

backward, left and right side by the android application such as Arduino, Bluetooth. Bluetooth has changed how people use digital device at home or office, and has transferred traditional wired digital devices into wireless devices. This paper gives us an idea of making these multifunctional robot from the idea of bluetooth controlled robotic car.

## **2. Next-Generation UV: Evaluation of a Robotic Ultraviolet-C Room Disinfection Device[2]**

Another paper on "Next-Generation UV: Evaluation of a Robotic Ultraviolet-C Room Disinfection Device" authored by Jennifer Cadnum, BS.1;

Christina Piedrahita, BS2; Annette Jenson, BSMT(ASCP)SM, CIC2; J. Itty Mathew, MLS3 and Curtis J. Donskey published in 2017 basically focused on Uvc light decontamination. In these literature A robotic UV-C device programmed to automatically navigate the room. Here they compared the efficacy of a standard UV-C room disinfection device operated in one location and a robotic, UV-C device with 3 adjustable lamps that automatically navigates around the patient room to minimize distance from the device and shadowing. the robotic device operated in a stationary position was as effective as the standard device against organisms in close proximity to the device (~2–3 feet from the device), but significantly less effective at greater distances. This is effective in reducing contamination at sites throughout the room. Whole room ultraviolet-c disinfection has been widely studied throughout this literature.

## **3. Low cost Indoor navigation System for Food Delivery Robot Based on Multi-Sensor Information Fusion[3]**

Several systems are being proposed everyday by researchers and students. Yunlong Sun , Lianwu Guan , Zhanyuan Chang 2, Chuanjiang Li and Yanbin Gao's " Low cost Indoor navigation System for Food Delivery Robot Based on Multi-Sensor Information Fusion" published by College of Automation, Harbin Engineering University, Harbin 150001, China; in 2019. Introduces the current situation of service robots at home and abroad and extends to the food delivery machine. The meal delivery robot positioning system consists of a combination of UWB positioning and odometer

positioning systems. This paper presents a meal delivery robot with positioning and navigation control based on the fusion of information from multiple sources or technologies, namely UWB positioning, an odometer, a low-cost gyroscope accelerometer, and an electronic compass. This establish the kinematics model of the delivery robot. To improve the positioning accuracy and stability effectively, they fuse the positioning results of the UWB system with those of odometer and a dead reckoning algorithm. The algorithm used for the fusion is an extended Kalman filter (EKF) fusion algorithm, which is suitable for discrete systems in the presence of Gaussian white noise. The designed robot can move along the preset path without the need for laying a navigation track. From this paper we have take an idea of food delivery robot. As, the hospitals are facing labour shortage issue thats why, the food delivery robot is beneficial.

## **4. Robotics Utilization for Healthcare Digitization in Global COVID-19 Management[4]**

Considering the current disastrous situation, robots are well suited for caring for the well-being of COVID-19 patients thus replacing or at least sharing the workload of the medical staff in hospitals under oversaturated conditions. This paper describes the evolving role of robotics in healthcare and allied areas with special concerns relating to the management and control of the spread of the novel coronavirus disease 2019 (COVID-19). The prime utilization of such robots is to minimize person-to-person contact and to ensure cleaning, sterilization and support in hospitals and similar facilities such as quarantine. This will result in minimizing the life threat to medical staff and doctors taking an active role in the management of the COVID-19 pandemic. The intention of the present research is to highlight the importance of medical robotics in general and then to connect its utilization with the perspective of COVID-19 management so that the hospital management can direct themselves to maximize the use of medical robots for various medical procedures. This is despite the popularity of telemedicine, which is also effective in similar situations. The basic thing is, the recent achievement of the Korean and Chinese health sectors in obtaining active control of the

COVID-19 pandemic was not possible without the use of state of the art medical technology.

### III. PROPOSED DIAGRAM

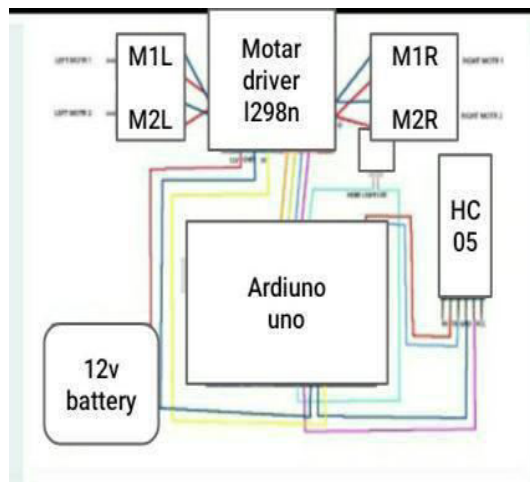

Figure 1: Block diagram of the proposed system

The robot has 4 dc motor which will run by motor driver. We are using one Arduino uno which will interface with motor driver. To operate the robot by wireless we are using HC05 Bluetooth module which is wireless Bluetooth module having range up to 35 feet's Or 10 meter which is connected to motor driver. Then the ultraviolet c light lamp is place in front side of robot which kill the germs and viruses. For cleaning the surface we have place one dc motor which connects to the cleaning thing And the robot has trolley which helps to provide necessary things to patient.

### VI. CONCLUSION

From this literature survey we have seen that the robots are utilized in hospital for either providing service like medicine or food delivery or cleaning or uv disinfecting purpose. In above literature robots performed the single work at a time. This robots are very costly & time consuming. That's why we derived simple solutions to provide a structure for hospital with very low cost but with high figuring and sensing capabilities provided by the smart phone that

is used as a control device. This robot performs multifunctions like uv cleaning, food delivery, sanitizing & floor cleaning. This robot is time saving. This robot provides the contact free service, hence it can be used in hospitals, small clinics to maintain a safe distance. As covid-19 pandemic is going on, this robot will be very beneficial in our normal life and will bring much needed innovation in this fast changing world of technology.

### V. REFERENCES

1. Ayan Maity, Avijit Paul, Priyanka Goswami, Ankan Bhattacharya. Android Application Based Bluetooth Controlled Robotic Car. International Journal of Intelligent Information Systems. Vol. 6, No.5,2017,pp.6266.doi:10.11648/j.ijis.20170605.12
2. Next-Generation UV: Evaluation of a Robotic Ultraviolet-C Room Disinfection Device oct 2017 by Jennifer Cadnum, BS.1; Christina Piedrahita, BS2; Annette Jencson, BSMT(ASCP)SM, CIC2; J.
3. Design of a Low-Cost Indoor Navigation System for Food Delivery Robot Based on Multi-Sensor information Fusion by Yunlong Sun 1, Lianwu Guan 1,\* , Zhanyuan Chang 2,\* , Chuanjiang Li 2 and Yanbin Gao 1. Sensors 2019, 19, 4980; doi:10.3390/s19224980.
4. Zeashan Hameed Khan 1, Afifa Siddique 2, Chang Won Lee 3. Robotics utilization for healthcare digitization in global COVID-19 management. Int. J. Environ. Res. Public Health 2020, 17, 3819.
5. Itty Mathew, MLS3 and Curtis J. Donskey Taylor, R.H.; Kazanzides, P.; Fischer, G.S.; Simaan, N. Medical Robotics and Computer-Integrated Interventional Medicine; Elsevier: Amsterdam, The Netherlands, 2020; pp. 617–672.
6. Bouteraa, Y.; Ben Abdallah, I.; Ghommam, J. Task-space region-reaching control for medical robot manipulator. Comput. Electr. Eng. 2018, 67, 629–645, doi:10.1016/j.compeleceng.2017.02.004.

7. Zhang Y., Lu M. A review of recent advancements in soft and flexible robots for medical applications. *Int. J. Med. Robot. Comput. Assist. Surg.* 2020;16 doi: 10.1002/rcs.2096.
8. Huang, C.; Wang, Y.; Li, X.; Ren, L.; Zhao, J.; Hu, Y.; Zhang, L.; Fan, G.; Xu, J.; Gu, X.; et al. Clinical features of patients infected with 2019 novel coronavirus in Wuhan, China. *Lancet* 2020, 395, 497–506, doi:10.1016/s0140-6736(20)30183-5.
9. Balasubramanian, S.; Chenniah, J.; Balasubramanian, G.; Vellaipandi, V. The era of robotics: Dexterity for surgery and medical care: Narrative review. *Int. Surg.* 2020, 7, 1317, doi:10.18203/2349-2902.isj20201057.
10. Vänni, K.J.; Salin, S.E.; Kheddar, A.; Yoshida, E.; Ge, S.S.; Suzuki, K.; Cabibihan, J.-J.; Eyssele, F.; He, H. A Need for Service Robots Among Health Care Professionals in Hospitals and Housing Services. *Appl. Evolut. Comput.* 2017, 10652, 178–187, doi:10.1007/978-3-319-70022-9\_18.