

THERMOSTAT MODEL FOR CONTROLLING A COOLING SYSTEM

¹Prof .A. R. Mankar, ²Prof. Y. N. Chopkar, ³Kunal D. Nishad

¹Prof. A.R. Mankar, Guru Nanak Institute of Technology, Heat & Power

²Prof. Y. N. Chopkar, Guru Nanak Institute of Technology, Heat & Power

³Kunal D. Nishad, Guru Nanak Institute of Technology, Heat & Power

ABSTRACT – This paper proposes Thermostatic Model for Controlling a cooling system model scheme to provide temperature set-points to thermostatic controlled cooling units in CNC machines We can use it where the temperature of material should be maintain between Lower and higher value. . The control problem is formulated as a convex programming problem to minimize the overall operating cost of the system. Temperatures are estimated by reduced order observers and evaporation temperature is regulated by an algorithmic suction pressure control scheme. The method is applied to a validated simulation benchmark. The results show that even with the thermostatic control valves, there exists significant potential to reduce the operating cost. View less This is a research topic and more development is required in this project.

Key Words: Temperature sensor, Controlling unit, Relay, LCD, Pump.

1. INTRODUCTION

There is a large variety of thermostat models on the market with functionality for various mechanisms and fields. In the present paper we considered thermostat models used for cooling systems and therefore we developed a practical, easy to use thermostat prototype which can be adjusted for systems in aimed area. One of the primary advantages this model brings is that it can be programmed in accordance with the application is designed for by the means of Arduino board and software. Through the programme the prototype can be updated according to the requirements of the application it is used for. As a novelty it was introduced parameter hysteresis used as a lower limit for the cooling system. Once data uploaded on Arduino board, all thermostat needs is a 12V power supply.

The thermostat is a component frequently used in systems that need cooling or heating like heating stations, boilers, refrigerators, automobile engines and many other devices and mechanisms. In the present paper we designed and developed a thermostat model that can be used for different cooling systems. For prototype build-up there were used electronic components and software needed for thermostat programming [1], [11], [14]. Base component is Arduino UNO board which uses programming interface Arduino IDE 1.8.7. A sensor detects the temperature and this value is compared to a Set Point established in the

programme. If the measured value is higher than the Set Point Arduino UNO board sends an impulse USING PIN 8 to the transistor which actuates upon the cooling system. The cooling process works until temperature value reaches the hysteresis value set by the programme.

2. LITERATURE SURVEY

Many existing system for temperature monitoring and controlling generally uses micro-controller ATMEL 89C51 (μc 8051). It does the same job by using additional devices. The microcontroller-controlled system contains essentially four parts, i.e., the process, the analog to digital converter, the control algorithm, and the clock. The times when the measured signals are converted to digital form are called the sampling instants; the time between successive samplings is called the sampling period and is denoted by h . The output from the process is a continuous time signal. The output is converted into digital form by the A – D converter. The conversion is done at the sampling times. Problem Associated With Existing System Many existing system for temperature monitoring and controlling generally uses micro-controller ATMEL 89C51 (μc 8051). Due to using micro controller 8051 the process of making whole device becomes not only very complex but also difficult and tedious. For operation it requires A-D converter, external clock, microcontroller development board. Consequently, the problems are as follows:-

- a) It takes comparatively more time to process.
- b) It requires additional devices for operation.
- c) It requires external clock.
- d) Programming for microcontroller 8051 is difficult.
- e) For programming it requires development system.

Liu Peng, Fu Danni, Jiang Shengqian and Wang Mingjie presented a paper on A Movable Indoor Air Quality Monitoring System. This paper provides an intelligent movable indoor environment monitoring system based on Arduino's control using various sensors to detect air quality, which has been designed to simulate users' indoor route and detect air quality real-time to help acquire indoor air condition exactly [3].

Sherin Abraham and Xinrong Li presented paper on Cost-effective wireless sensor network system for indoor air quality monitoring applications. In this paper, they presented a low-cost indoor air quality monitoring wireless sensor network system developed using Arduino, XBee modules, and micro gas sensors. The system that they have developed is capable of collecting six air quality parameters from different locations simultaneously [4].

Gianpiero Einaudi and Walter Mortara presented a paper on Engine cooling electronic control system. An electronic control system has been developed to control the heat exchange in the engine, so as to maintain the engine structure temperature at full- power levels, whatever the operating conditions. This paper discusses the system design criteria and provides a description of the tests made on engine and vehicle [5]

. Research Methodology to be Employed:

Proposed system will have 6 building components.

1. Power supply 12Volt
2. Controller board (arduino Uno /Nano)
3. Temperature sensor
4. Relay
5. Pump
6. LCD display

Fig.:Diagram of project models

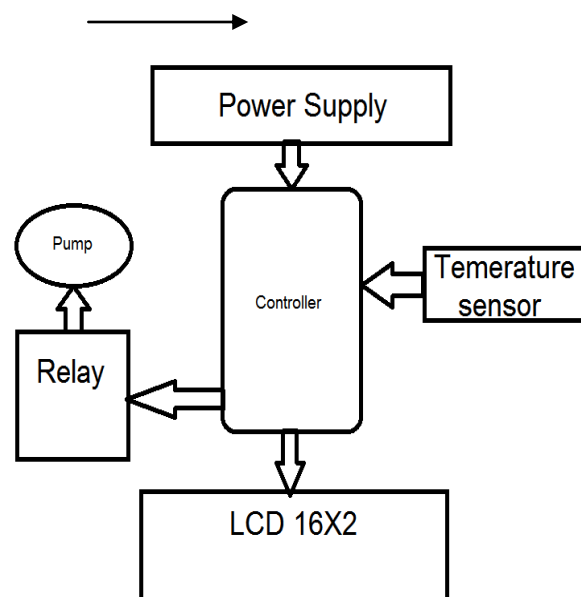

3. PROBLEM DEFINATION:

Most CNC machine tools have a coolant delivery system designed to handle a limited range of applications. In the real world, however, your setups can be extremely varied so you need lots of options for getting coolant to cutting edge. No single nozzle will work for all applications. Thats why we have engineered a An automatic coolant nozzle control for CNC machines using Microcontrollers

An automatic coolant nozzle control for CNC machines using Microcontrollers is designed with servo motors which are controlled using joystick for better accuracy adjustment of water coolant nozzles on BFW CNC machine for different shapes and lengths.

4. OBJECTIVES:

The main objective of the project is to provide controlled cooling system for heating material with help of coolant controller.

1. To increase life of CNC tool.
2. To automate the process of using coolant

METHODOLOGY:

As soon as we connect power supply the welcome message will be there on LCD. Meanwhile the temperature sensor will be initialized.

Current temperature value will be shown on LCD display.

Comparing with the threshold temperature value we will decide whether to on or off the coolant pump.

SCOPE:

1. It could be used for any machine where the coolant is required to perform job.
2. Smart Thermostat for coolant dispenser system
3. It could be used for automobile engine or any heating chamber to maintain temperature.

3. CONCLUSIONS

There are currently many different hybrid-electric system designs utilizing clean diesel engines, alternative fuel engine, gas turbine or fuels cells conjunction with batteries. There are even some new technology concept in the development stage that is solar panel with battery with out using the any kind of fuel. Us of two different of energy sources define a hybrid.

There is one of the battery alternate vehicles to fulfill the today's requirement. After 10 or 20 years crises must become at that time we must think of this alternative machines. It basically based on solar plus battery which makes it different from the others in the field of the today's required to reduced the pollution.

It's the better option with less vibration, low cost, low maintenance or totally less emission as compare to the other machines.

ACKNOWLEDGEMENT

I am over helmed in all humbleness and gratefulness to acknowledge my depth to all those who have to put helped me put these ideas, I am exchange of ideas generates the new object to work in a better way whenever a person in helped and cooperated by others his heart is bound to pay gratitude and obligation to my couligs to do this wonderful project on the “**THERMOSTAT MODEL FOR CONTROLLING A COOLING SYSTEM**”, which also helped me in doing a lot of Research and I came to know about so many things. I am really thankful to them.

REFERENCES

- 1) Samuel Ndueso John, Charles Ndujiuba, Oladeinde Ifedayo Oluwaseyi, Ibeanu Charity Onyinye, “Design and Implementation of a Microprocessor based Temperature Controller with Real Time Display”, International Conference Comp., Energy, Net. , Robotics and Telecom, pp.14-18, 2012.
- 2) Yang Cao, Chaochao Zhong, Kaiwen Qiu, “Design and Experiment About Temperature

Control System Of Sealing Machine Based On Fuzzy PID”, 8 th International Conference on Intelligent Human-Machine Systems and Cybernetics, pp. 308-311, 2016 IEEE.

- 3) James S. McDonald, “Temperature Control Using a Microcontroller: An Interdisciplinary Undergraduate Engineering Design Project”, 1997 Frontiers in Education Conference, pp. 1620-1624, 1997 IEEE.
- 4) Hitu Bansal, Dr. Lini Mathew, Ashish Gupta, “Controlling of Temperature and Humidity for an Infant Incubator Using Microcontroller”, International Journal of Advanced Research in Electrical and Electronics and Instrumentation Engineering, vol. 4, no. 6, pp. 4975-4982, June 2015.
- 5) Nwankwo Nonso Prince , Alumona Theophilus , Onwuzulike Daniel .A., Nwankwo Vincent, “Design and Implementation of Microcontroller based Automatic Fan Speed Regulator (Using Temperature Sensor)”, International Journal of Engineering Research and Management (IJERM), vol. 01, no.5, pp. 202-208, August 2014..
- 6) Aakanksha Pimpalgaonkar, Mansi Jha, Nikita Shukla, Kajol Asthana, “A Precision Temperature Controller using Embedded System”, International Journal of Scientific and Research Publications, vol.3, no.12, pp.1-3, December 2013
- 7) A. L. Amoo, H. A. Gud, H. A. Sambo, T. L. G. Soh, “Design and Implementation of a Room Temperature Control System: Microcontroller-Based”, IEEE Trans. Energy Conservation , 2014.
- 8) S. V. Devika, Sk. Khamuruddeen, Sk. Khamurunnisa, J. Thota and K. Shaik, Arduino Based Automatic Plant Watering System, IJARCSSE, vol 4, issue 10, pp. 449-456, 2014.
- 9) J. J. Roldán, G. Joossen, D. Sanz, J. del Cerro and A. Barrientos, Mini-UAV Based Sensory System for Measuring Environmental Variables in Greenhouses, Sensors, vol 15, pp. 3334-3350, 2015.

- 10) Arduino; Unsigned Long Data Type Reference Sheet, <https://www.arduino.cc/en/Reference>