

# Design and Implementation of Grid Interfacing System for Renewable Energy Sources

S Kranthi Kumar<sup>1</sup>, Pekala Vanitha<sup>2</sup>, Pasagadugula Komali<sup>3</sup>

G Krishna Siva Naga Tarun<sup>4</sup> Mulli Sai Bhargavi<sup>5</sup> Rongali Dinesh<sup>6</sup>

Associate Professor, Department of EEE, Raghu Engineering College, Visakhapatnam, A.P, India.<sup>1</sup>

B. Tech Scholar, Department of EEE, Raghu Engineering College, Visakhapatnam, A.P, India.<sup>2,3,4,5,6</sup>

## ABSTRACT

*This paper presents an advanced control architecture for a standalone, single-phase micro grid system designed to enhance power quality and ensure frequency stability under diverse operating conditions. The proposed system facilitates the seamless integration of a governor-less micro-hydro turbine, driven by a two-winding self-excited induction generator (SEIG), alongside a wind-powered permanent magnet brushless DC (PMBLDC) generator, a solar photovoltaic (PV) array, and a battery energy storage system (BESS).*

*An Adaptive Sliding Mode Control (ASMC) algorithm is implemented to estimate reference source currents, enabling precise regulation of the micro grid's voltage and frequency while effectively mitigating harmonic distortion. Furthermore, a secondary sliding mode control mechanism is employed to maintain real-time energy balance by estimating the system's reference real power, ensuring that the BESS compensates for fluctuations in wind, hydro, and solar generation. To address non-linear load disturbances and improve power quality, a fuzzy logic controller is integrated to suppress harmonic currents. The robustness of the proposed control strategy is validated through comprehensive simulation studies in the MATLAB/Simulink environment, demonstrating consistent grid voltage and frequency stability during sudden load transitions and variable intermittent power penetration.*

**KEYWORDS:** Adaptive Sliding mode controller, micro grid, Renewable energy sources.

## I. INTRODUCTION

The benefits of an integration of renewable energy sources like wind, solar and micro-hydro with BESS (Battery Energy Storage System) are currently well recognized. The function of micro grid as controlled

entities explores the possibility of coordinating standalone renewable energy sources so that they behave as a single producer of electrical energy to avail the full advantages of renewable energy resources in a consistent and manageable way. The energy balance and system parameters control are the key features of the micro grid. In order to achieve proper integration of renewable energy sources (RES), the development of effective frequency and voltage control scheme is essentially desired [1] - [2]. The concept of micro grid is most interesting for successful dealing with the challenges in the integration of renewable energy sources [3]. A micro grid is having capability to operate in both standalone and grid tied modes operation depending upon the design of suitable control scheme [9] - [10]. The various derived forms of the micro grid such that virtual power plant, cognitive micro grid and active distribution system can be studied as a main constituent of smart grid [4] - [8]. In grid tied micro grid, the main grid supplies the deficit power and absorbs the surplus power in a grid tied micro grid in order to maintain power balance which in turn regulates the system frequency. Whereas, in a standalone micro grid, the balance of active and imaginary powers, is achieved using controlling the flow of power among different components of the micro grid [9] - [10]. An IEEE standard for interconnection of distributed energy sources are given in [11]. The voltage, frequency, real and imaginary powers are the main system variables required to control the operation of the micro grid [11]. BESS allows the large scale integration of intermittent energy sources [12].

The adaptive sliding mode control (ASMC) eliminates all possibilities of overshoot and undershoot problem in DC link voltage of the VSC which reduces the required size of DC link capacitor and BESS. The proposed control reduces the size required for DC link capacitor connected across the BESS. The proposed control never allows the increase of DC link voltage above the maximum float charge voltage that increases



AC voltage is estimated and generated using frequency estimation and phase shifting (FEPS) block [18]. The micro grid AC voltage may be expressed as,

$$v_p = V_t \sin \omega t$$

$$v_q = V_t \cos \omega t \tag{2}$$

Where  $v_p$  is the instantaneous AC voltage,  $V_t$  is the amplitude and  $\omega$  is the angular frequency of the micro grid AC voltage. The in-phase and quadrature unit templates of micro grid AC voltage are derived as,

$$u_q = \frac{v_q}{V_t} \text{ and } u_p = \frac{v_p}{V_t} \tag{3}$$

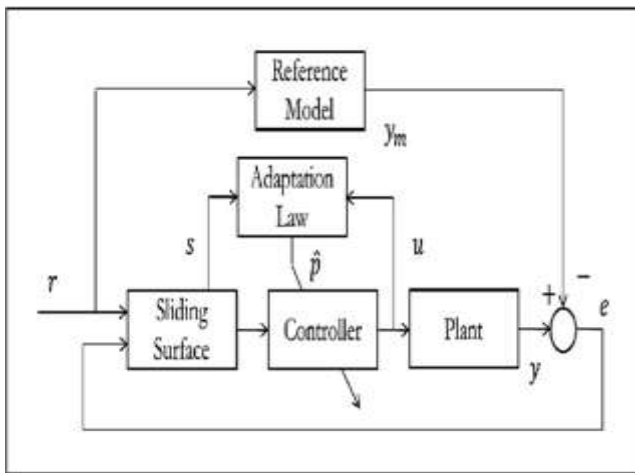

Fig2.2: Adaptive Sliding Mode Controller

An Adaptive control system automatically compensates for variation in system dynamics. By adjusting the control characteristics so that the overall system performance remains the same or rather maintained at optimum level.

The in-phase part of reference source current is responsible for frequency control of the system and power balance among SEIG, PMLDC generator, solar PV-array, battery and the load. In proposed ASMC control algorithm, an adaptive filter is used to extract the amplitude of fundamental active and reactive power constituents of load current. The proposed control algorithm is a combination of two control loops. First loop controls its voltage by injecting an adjustable reactive power and other loop maintains active power balance among various energy elements in the micro grid.

**III.SIMULATION DESIGN AND RESULTS:**

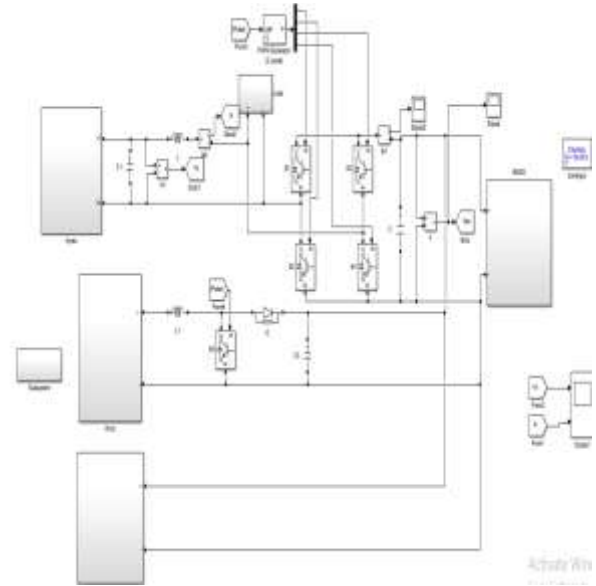

Fig3.1a) Simulation Design

Dynamic Performance Of Proposed Micro Grid:i) Dynamic Performance of Proposed Micro grid at a Step Change in Solar Insolation Level

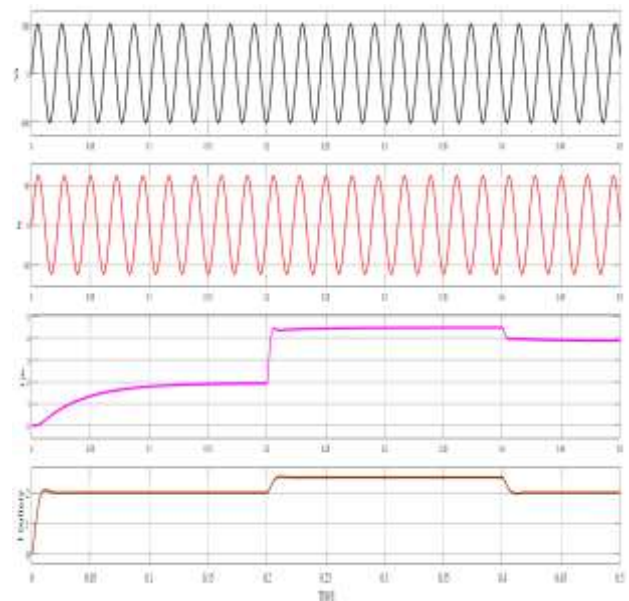

Fig 3.2(a) Dynamic Performance of the Vs, Is, Ipv and Ibattery, While the system is following a step increase and decrease in Insolation Level

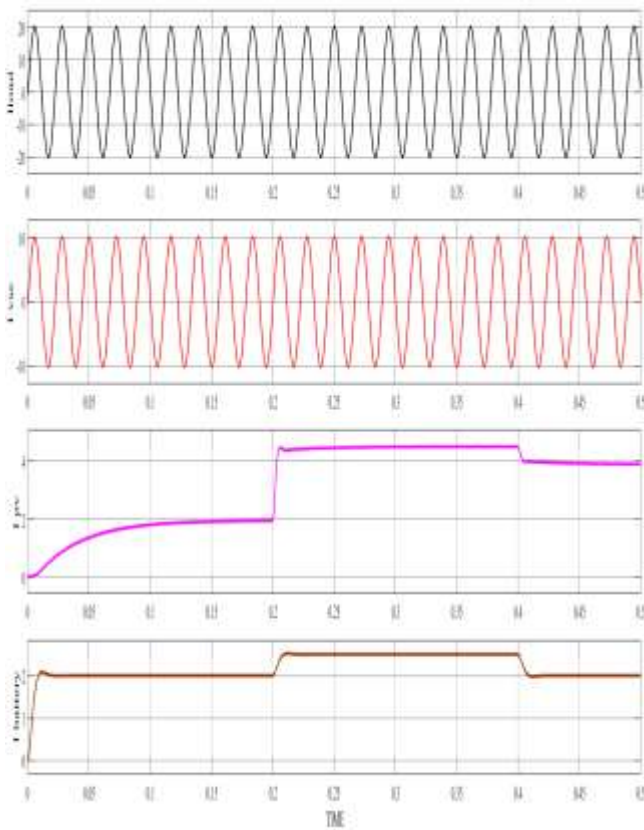

Fig 3.2(b) Dynamic Performance of the  $I_{load}$ ,  $I_{vsc}$ ,  $I_{pv}$  and  $I_{battery}$ , While the system is following a step increase

The dynamic performance of the system voltage, SEIG current, solar PV-array current and battery current while the system is following a step decrease in insolation level, are demonstrated in . It is observed from test results shown that the step decrease in insolation level causes a decrease the solar PV-array current with the same slope and it subsequently decreases the battery current but it does not disturb the system AC voltage, load current or system frequency. The battery current goes from charging to discharging mode in order to regain the power balance in the system as shown in Fig. Test results show that the system frequency and voltage are maintained constant during this dynamic condition.

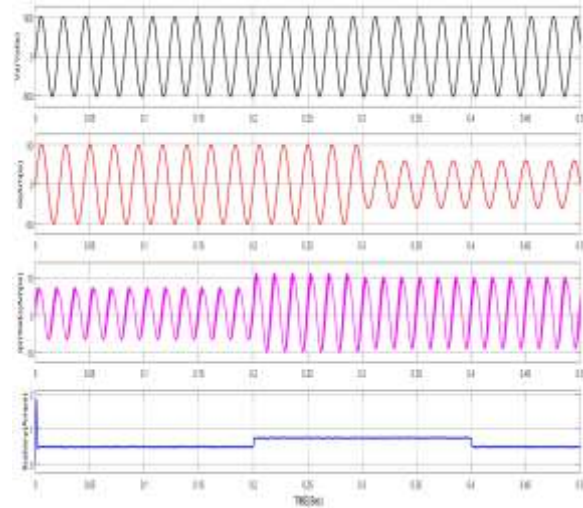

Fig 3.3 Dynamic Response of  $V_s$ ,  $I_s$ ,  $I_{pmbldc}$ ,  $I_{battery}$ , while the system is following a step increase and decrease in wind speed

## CONCLUSION

The adaptive sliding mode control algorithm for voltage and frequency control of standalone single-phase micro grid has been implemented. The proposed SEIG based standalone micro grid has integrated three main renewable sources including micro-hydro, solar PV, and wind energy. Test results have proven that the ASMC algorithm has been effective and has good control of the Microgrid voltage and frequency. The proposed control algorithm has also improved the power quality of the microgrid under linear and nonlinear loads and also ensures the optimum utilization of BESS and renewable energy sources. To reduce the harmonics of the system Fuzzy Logic Controller is introduced to the and the results are Compared with MATLAB/SIMULINK environment.

## REFERENCES:

- [1]. P. Dondi, D. Bayoumi, C. Haederli, D. Julian, and M. Suter, "Network integration of distributed power generation," *J. of Power Sources*, vol.106, no. 1–2, pp. 1–9, 2002.
- [2]. J. P. Lopes, N. Hatzargyriou, J. Mutale, P. Djapic, and N. Jenkins, "Integrating distributed generation into electric power systems: A review of drivers, challenges and opportunities," *Electric Power Syst. Research*, vol. 77, no. 9, pp. 1189–1203, 2007.
- [3]. N. Hatzargyriou, H. Asano, R. Iravani, and C. Marnay, "Microgrids," *IEEE Power Energy Mag.*, vol. 5, no. 4, pp. 78–94, Jul./Aug. 2007.

- [4]. N. Ruiz, I. Cobelo, and J. Oyarzabal, "A direct load control model for virtual power plant management," *IEEE Trans. Power Syst.*, vol. 24, no. 2, pp. 959–966, May 2009.
- [5]. H. Morais, P. Kádár, M. Cardoso, Z. A. Vale, and H. Khodr, "VPP operating in the isolated grid," in *Proc. IEEE Power and Energy Soc. General Meet.*, 2008, pp. 16.
- [6]. D. Pudjianto, C. Ramsay, and G. Strbac, "Virtual power plant and system integration of distributed energy resources," *IET Renew. Power Gener.*, vol. 1, no. 1, pp. 10–16, Mar. 2007.
- [7]. A. Molderink, V. Bakker, M. G. C. Bosman, J. L. Hurink, and G. J. M. Smit, "Management and control of domestic smart grid technology," *IEEE Trans. Smart Grid*, vol. 1, pp. 109–119, Sep. 2010.
- [8]. D. Pudjianto, C. Ramsay, and G. Starbac, "Microgrids and virtual power plants: Concepts to support the integration of distributed energy resources," in *Proc. Inst. Mech. Engineers, Part A: J. Power and Energy (IMEchE)*, 2008, vol. 222, pp. 731741.
- [9]. H. Karimi, H. Nikkhajoei, and M. R. Iravani, "Control of an electronically-coupled distributed resource unit subsequent to an islanding event," *IEEE Trans. Power Del.*, vol. 23, no. 1, pp. 493–501, Jan. 2008.
- [10]. F. Katiraei, M. R. Iravani, and P. W. Lehn, "Microgrid autonomous operation during and subsequent to islanding process," *IEEE Trans. Power Del.*, vol. 20, no. 1, pp. 248–257, Jan. 2005.
- [11]. IEEE Standard for Interconnecting Distributed Resources with Electric Power Systems, 2003, IEEE Std. 1547.
- [12]. R. Zamora and A. K. Srivastava, "Controls for microgrids with storage: Review, challenges, and research needs," *Renewable and Sustainable Energy Reviews*, vol. 14, no. 7, pp. 2009–2018, Sep. 2010.
- [13]. A. Hajimiragha and M. R. D. Zadeh, "Practical aspects of storage modeling in the framework of microgrid real-time optimal control," in *Proc. IET Conf. on Renewable Power Generat. (RPG)*, Sep. 2011, pp. 93–98.
- [14]. F. Blaabjerg, R. Teodorescu, M. Liserre, and A. V. Timbus, "Overview of control and grid synchronization for distributed power generation systems," *IEEE Trans. Ind. Electron.*, vol. 53, no. 5, pp. 1398–1409, Oct. 2006.