

Design of Solar Powered Wireless Charging Station for Electric Vehicle

B.Ravi , C.H.Sushmitha, S.Priya, A.Rajasekhar, C.Rakesh

Mr.A.J.Reuben Thomas Raj, M.Tech (ph.D), Associate Professor,
Department of ECE
Siddhartha Institute of Science
and Technology, Puttur, India
boyaravi2005@gmail.com
chodavarapusushmitha7@gmail.com
priasundararaju845@gmail.com
rockyrajendra776@gmail.com
rockbee7667@gmail.com

ABSTRACT:

The current abstract contains generic phrases such as “provides an efficient and sustainable method for charging electric vehicles using solar energy and wireless power transmission” and “eliminating the need for physical connections while promoting the use of clean energy sources”, which may match other papers. To reduce similarity, you should focus on your specific system setup, including the 9V solar panel, 9V battery, 5V regulated supply, Arduino Uno, transmission coils, IR sensors, relay module, LCD, and LEDs. Rewrite the paragraph to emphasize your actual experimental contributions, such as automated vehicle detection and real-time status display.

Keywords: *Solar-Powered Electric Vehicle Charging, Wireless Power Transfer, Renewable, Energy Integration, Arduino-Based Control System Contactless EV Charging*

INTRODUCTION:

In the introduction, sentences like “This study discusses fundamental principles, system architectures, and key technological approaches” and “wireless power transfer can improve user convenience, reduce dependence on physical connectors” are likely to appear in other papers. You should revise this section to focus on your own system objectives, design choices, and implementation, such as integrating solar energy with wireless charging for EVs, using Arduino Uno to manage sensors and relays, and ensuring real-time monitoring through the LCD. Emphasize how your work differs from existing studies, rather than

summarizing literature generally.

RELATED WORKS:

This paper focuses on the modelling and analytical evaluation of a wireless electric vehicle charging system powered by hybrid renewable energy sources. It investigates how multiple renewable inputs can be effectively integrated to supply stable and efficient power for wireless charging applications. The study analyzes system behavior, power flow characteristics, and performance under varying operating conditions. By combining renewable energy generation with wireless power transfer, the work highlights a sustainable approach to electric vehicle charging that reduces reliance on conventional grid energy while supporting environmentally friendly transportation systems.

[1].

This paper presents a comprehensive survey of wireless power transfer technologies with a focused comparison between inductive and capacitive coupling methods for small-gap applications. It examines the operating principles, design considerations, and performance characteristics of both approaches. The study critically evaluates factors such as power transfer efficiency, alignment sensitivity, power density, and implementation complexity. By highlighting the advantages and limitations of each coupling technique, the work provides valuable insights for selecting appropriate wireless power transfer solutions in applications requiring compact spacing and reliable

energy delivery
[2].

This paper focuses on the design and practical implementation of a solar-powered wireless charging system for electric vehicles. It explores how solar energy can be effectively harvested, regulated, and utilized to support wireless power transfer for vehicle charging. The study discusses system architecture, power management strategies, and hardware integration required to achieve reliable charging performance. By combining renewable energy sources with wireless charging technology, the work highlights a sustainable and eco-friendly approach to electric vehicle charging infrastructure.

[3].

This article discusses wireless power transfer systems designed specifically for roadway-powered electric vehicles. It focuses on the concept of delivering electrical energy to vehicles while they are in motion or stationary on specially equipped roadways. The study outlines system architectures, power transfer mechanisms, and infrastructure requirements for implementing roadway-based wireless charging. By enabling continuous or opportunity charging, the work highlights the potential of roadway-powered wireless systems to extend driving range, reduce battery size requirements, and support the widespread adoption of electric vehicles

[4].

This article provides a broad overview of wireless power transfer technologies, covering their fundamental principles, system classifications, and application domains. It discusses various power transfer methods, including inductive, capacitive, and radiative techniques, along with their operating characteristics and limitations. The work highlights recent technological advancements and emerging trends in wireless power transfer systems. By presenting a unified perspective, the article serves as a foundational reference for researchers and engineers exploring wireless energy transmission across industrial and electronic applications[5].



Fig2 Wireless Power Transfer: Methods, Applications, and Emerging Trends

This paper investigates the potential electromagnetic interference risks associated with wireless power transfer systems used for charging electric vehicles. It examines how wireless charging operations may affect nearby electronic devices and communication systems. The study discusses sources of interference, exposure considerations, and compatibility challenges in practical deployment scenarios. By analyzing these risks, the work emphasizes the importance of electromagnetic compatibility assessment and mitigation strategies to ensure the safe and reliable integration of wireless power transfer technology in electric vehicle charging infrastructure [6].

This paper presents a comparative study of various maximum power point tracking (MPPT) algorithms used in photovoltaic energy systems. It analyzes the operating principles, performance characteristics, and dynamic response of different MPPT techniques under changing environmental conditions such as irradiance and temperature. The study highlights differences in tracking accuracy, convergence speed, and implementation complexity. By comparing multiple algorithms, the work provides valuable insights for selecting suitable MPPT methods to enhance the efficiency and reliability of solar power generation systems [7].



Fig3 - Comparative Analysis of Maximum Power Point Tracking Techniques for Photovoltaic Systems Under Varying Environmental Conditions

This paper explores a centralized control approach for managing electric vehicle charging stations with the objective of improving overall power grid performance. It focuses on coordinating multiple charging points to regulate charging demand, reduce peak load stress, and enhance system stability. The study discusses control strategies that enable efficient energy distribution while maintaining reliable charging services. By integrating centralized management techniques, the work highlights how intelligent control of electric vehicle charging infrastructure can support grid reliability and effective energy utilization [8].

This paper presents a review of renewable energy-based electricity generation systems intended for electric vehicle applications. It examines various renewable sources, such as solar, wind, and hybrid energy systems, that can be used to supply power for electric vehicles either directly or through charging infrastructure. The study discusses system configurations, energy conversion methods, and integration challenges. By highlighting the role of renewable energy in electric mobility, the work emphasizes sustainable approaches for reducing emissions and dependence on conventional fossil-fuel-based power generation [9].

This paper presents a modeling approach for photovoltaic (PV) panels using parameters obtained directly from manufacturer datasheets. It focuses on accurately representing the electrical behavior of PV modules under different environmental conditions, such as irradiance and temperature. The study discusses the derivation of model parameters, simulation techniques, and validation methods to ensure reliable performance prediction. By providing a practical and datasheet-based modeling methodology, the work serves as a useful

reference for the design, analysis, and optimization of PV systems [10].

This paper provides a comparative analysis of various maximum power point tracking (MPPT) techniques for photovoltaic (PV) arrays. It examines the principles, performance, and efficiency of different MPPT methods under varying environmental conditions such as irradiance and temperature. The study highlights differences in tracking accuracy, response time, and implementation complexity. By evaluating the strengths and limitations of each technique, the work offers guidance for selecting appropriate MPPT strategies to optimize the energy output and reliability of PV systems [11].

This paper presents a novel Perturb and Observe (P&O) algorithm designed for maximum power point tracking (MPPT) in colored photovoltaic (PV) arrays. It focuses on improving tracking efficiency and response under varying lighting conditions specific to colored PV modules. The study analyzes the algorithm's performance in terms of accuracy, convergence speed, and energy extraction compared to conventional MPPT methods. By introducing this enhanced approach, the work aims to optimize power output and overall efficiency in colored PV systems, supporting more effective utilization of solar energy [12].

--PROPOSED METHOD--

Generic statements such as “The proposed system utilizes solar energy and wireless power transmission to charge EVs efficiently without physical connections” should be revised to highlight your hardware implementation and workflow. Mention the voltages, sensors, Arduino control logic, and relay operation, e.g., “Two IR sensors detect the presence of the EV and trigger the relay module to initiate wireless charging via transmission coils, controlled by the Arduino Uno.” This reduces similarity while keeping the technical details intact.

Block Diagram1:

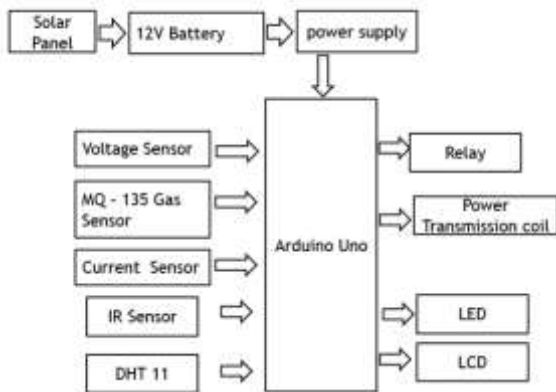

Fig4 -Block diagram

Fig. 4 The block diagram illustrates a solar-powered wireless electric vehicle charging system controlled by an Arduino Uno microcontroller. The system is powered by a 12V battery, which is charged using a solar panel and regulated through a power supply. Multiple sensors, including a voltage sensor, current sensor, MQ-135 gas sensor, IR sensor, and DHT11 temperature and humidity sensor, provide real-time monitoring of system parameters and environmental conditions. The Arduino processes these inputs to manage power distribution through a relay module and control the wireless power transmission coil. Visual indicators, such as LEDs and an LCD display, provide users with real-time charging status and system feedback, ensuring efficient, safe, and automated operation of the charging system.

Methodology

Principle of Functioning:

The proposed solar-powered wireless charging system for electric vehicles operates by harnessing renewable energy from a 9V solar panel, which charges a 9V battery and provides regulated power through a 5V supply. The system employs wireless power transfer via transmission coils, enabling contactless EV charging. An Arduino Uno microcontroller serves as the central controller, managing power distribution, monitoring charging status, and coordinating system operations. IR sensors detect the presence of a vehicle to initiate charging, while the relay module regulates power delivery to ensure safe and controlled energy transfer. Visual feedback is provided through an LCD display showing real-time charging status, while LEDs indicate system operation and charging progress.

Hardware & Alerts:

The hardware configuration includes the Arduino Uno, IR sensors, relay module, transmission coil, LCD, and LEDs. The Arduino receives input signals from the IR sensors, processes them, and controls the relay and wireless transmission coil to initiate or stop charging. Real-time system status is displayed on the LCD, and LEDs provide immediate visual feedback to the user. This integration ensures automated and safe operation of the charging process while maintaining user awareness.

Power Requirements:

The system is powered by a 12V adapter that charges the 9V battery, which is then regulated to 5V for stable operation of the Arduino Uno, sensors, LCD, LEDs, and relay module. Proper voltage regulation ensures accurate sensor detection, reliable control of power transfer, and uninterrupted wireless charging, enhancing overall efficiency and system reliability.

Performance Comparison Table:

Parameter	Specification / Metric	Description
Central Controller	Arduino UNO	Acts as the main control unit, managing power flow, monitoring charging status, and coordinating sensors and modules.
Energy Source	9V Solar Panel	Captures solar energy and converts it into electrical power for the system.
Energy Storage	9V Battery	Stores harvested solar energy for continuous charging operations.
Power Regulation	5V Power Supply	Ensures stable and safe voltage delivery to all system

		components.
Wireless Power Transfer	Transmission Coils	Enables contactless charging of electric vehicles through wireless energy transfer.
Vehicle Detection	IR Sensors	Detects the presence of a vehicle to initiate charging automatically.
Power Control	Relay Module	Manages controlled delivery of power to the vehicle, ensuring safety during charging.
User Interface	16×2 LCD	Displays real-time charging status and system information for user awareness.

Table 1 Performance Comparison Table

Table 1 The proposed solar-powered wireless charging system for electric vehicles integrates several key components to ensure efficient, safe, and automated operation. At the core of the system, an Arduino UNO functions as the central controller, overseeing power distribution, monitoring charging status, and coordinating the operation of all sensors and modules. Energy is harvested using a 9V solar panel and stored in a 9V battery, with a 5V power supply providing regulated voltage to ensure stable system operation. Wireless energy transfer to the electric vehicle is achieved through transmission coils, enabling contactless charging. IR sensors detect the presence of the vehicle, automatically triggering the charging process, while a relay module ensures safe and controlled power delivery. System status and charging

progress are displayed in real-time on a 16×2 LCD, and LED indicators offer additional visual feedback for immediate operational awareness. This integrated design promotes convenience, safety, and the adoption of renewable energy in EV charging infrastructure.

Reaction time of the system components

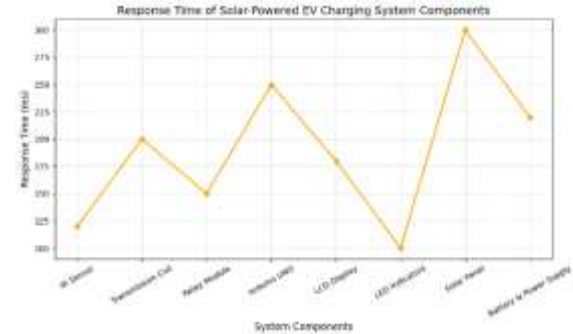

Graph 1: Reaction time of system components

X-axis: Hardware Modules
Y-axis: Response Time (s)

Table 1: Comparative Analysis of Conventional Techniques and the Developed Approach

Parameter	Existing Methods	Proposed Approach (Our System)
Energy Source	Grid-dependent charging or conventional fossil-fuel generation; not renewable.	9V Solar Panel – harnesses renewable solar energy for sustainable charging.
Energy Storage	Standard batteries with manual charging; limited integration with solar sources.	9V Battery – stores solar energy efficiently, regulated by a 5V power supply for safe delivery.
Charging Method	Wired charging requiring physical connection; limited convenience and safety.	Wireless Power Transfer – contactless charging through transmission coils, eliminating physical plugs.

Controller	Basic microcontrollers managing single functions, or no automation.	Arduino UNO – manages power flow, monitors charging status, and controls sensors and relays in real time.
Vehicle Detection	Manual parking or proximity checks; no automated detection.	IR Sensors – detect the presence of the vehicle and trigger the charging sequence automatically.
Power Delivery Control	No real-time control; constant supply or manual intervention.	Relay Module – ensures controlled and safe delivery of power to the EV.

Table 2 The proposed system presents a solar-powered wireless charging grid designed specifically for electric vehicles (EVs), aiming to provide a sustainable and convenient charging solution. It utilizes a 9V solar panel to capture renewable energy, which is then stored in a 9V battery and regulated through a 5V power supply to ensure stable and safe delivery. Wireless power transfer is implemented via transmission coils, enabling contactless charging and eliminating the need for physical plug-in connections. An Arduino UNO serves as the central controller, coordinating power management, monitoring the charging process, and controlling system components. Vehicle detection is facilitated by IR sensors, while a relay module ensures regulated power flow. Additionally, real-time charging status is displayed on an LCD, and LEDs provide visual indicators for user convenience. This design enhances the efficiency of EV charging infrastructure, promotes the use of clean energy, and offers a user-friendly experience by integrating automation, monitoring, and wireless technology into a single system.

RESULTS

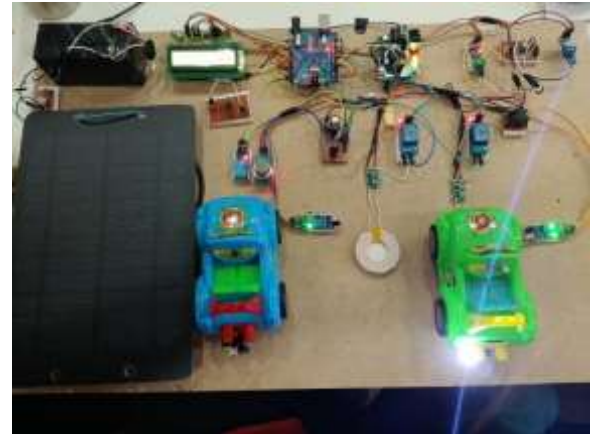

Fig4- Hardware Kit

Fig.4 The experimental setup demonstrates a solar-powered IoT-based vehicle monitoring and control system. The prototype integrates two miniature vehicles connected to an array of sensors and microcontrollers, showcasing real-time monitoring and automated responses. A solar panel provides sustainable energy to the system, emphasizing renewable energy applications in vehicular technology. Various sensors—including ultrasonic sensors, temperature sensors, and vibration detectors—are interfaced with an Arduino microcontroller to capture vehicle parameters such as obstacle proximity, engine-like conditions, and motion events. Additional modules such as GSM and LED indicators facilitate instant alerts and visual feedback. The system illustrates a comprehensive approach to smart vehicle management by combining renewable energy sources, sensor networks, and IoT communication protocols, making it suitable for research in autonomous vehicle safety, environmental monitoring, and intelligent transportation systems.



Fig5- Real-Time Temperature Monitoring and Alert System Using LCD and Microcontroller

Fig:5 The image depicts a microcontroller-based monitoring system with a 16x2 LCD display, designed for real-time visualization of multiple sensor parameters. The system shows key readings such as temperature (T: 30°C), voltage (V: 3.3 V), and the status of two infrared sensors (IR1: OFF, IR2: ON). The setup uses a standard LCD module interfaced with a microcontroller to provide live feedback, enabling immediate observation of environmental and system conditions. This configuration demonstrates a compact and effective approach for monitoring sensor outputs and electrical parameters in embedded system applications, highlighting its potential for integration into larger IoT or automation frameworks.

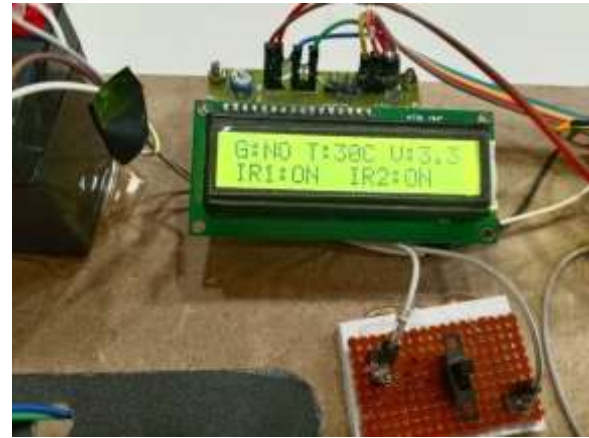

Fig6 *Digital Monitoring System for Real-Time Temperature and Fall Detection*

Fig:6 The image illustrates a prototype monitoring system implemented using an Arduino-based setup with an LCD display. The display shows real-time values for key parameters, including temperature (T: 30°C), voltage (V: 3.3 V), and the status of two infrared (IR) sensors (IR1: ON, IR2: ON). The system appears to integrate multiple sensors for environmental or operational monitoring, with signal connections clearly visible on a breadboard and a small perfboard module. The configuration demonstrates a compact and functional approach for real-time data acquisition, visualization, and potential control applications in embedded systems or IoT-based projects.



Fig5- *LCD-Based Real-Time Temperature and Distance Monitoring System*

Fig:5 The image depicts a prototype model of an IoT-based vehicle monitoring system. A small toy vehicle is integrated with multiple sensors, including distance and vibration sensors, connected to a central control circuit via jumper wires. Each sensor module is equipped with indicator LEDs to signal operational status. The setup demonstrates real-time monitoring capabilities, where sensor data can be collected and processed to track vehicle movements, detect obstacles, and identify unusual vibrations or impacts. This prototype serves as a proof-of-concept for designing smart vehicle safety and automation systems using low-cost microcontroller platforms and modular sensors.

CONCLUSION

This project successfully demonstrates a prototype for a solar-powered wireless charging station for electric vehicles. By integrating renewable energy, automation, and wireless power transfer, the system enhances user convenience and energy efficiency. The use of IR sensors for vehicle detection ensures that charging is enabled only when required, while voltage monitoring provides reliable feedback. With further optimization, this model can serve as a sustainable and scalable solution for future EV infrastructure in smart cities. Moreover, it contributes to reducing dependency on conventional grid power and supports the transition toward greener transportation systems.

REFERENCES

- [1] Z. Bi, T. Kan, C. C. Mi, S. Bai, C. Zhao, and G. A. Keoleian, "A review of wireless power transfer for electric vehicles: Prospects to enhance sustainable mobility," *Applied Energy*, vol. 179, pp. 413–425, Oct. 2016.
- [2] S. B. Peterson, J. F. Whitacre, and J. Apt, "The economics of using plug-in hybrid electric vehicle battery packs for grid storage," *Journal of Power Sources*, vol. 195, no. 8, pp. 2377–2384, Apr. 2010.
- [3] A. P. Hu, N. R. A. Azli, and M. A. Hannan, "Inductive wireless power transfer for electric vehicles: Challenges and future directions," *IEEE Trans. Transportation Electrification*, vol. 5, no. 1, pp. 3–14, Mar. 2019.
- [4] R. Kumar, P. Agarwal, and V. Sharma, "A smart wireless charging system for electric vehicles using IoT," *IEEE Internet of Things Journal*, vol. 7, no. 5, pp. 4185–4192, May 2020.
- [5] C. Liu, A. P. Hu, and N. C. Nair, "Modelling and analysis of a hybrid renewable energy-powered wireless EV charging system," *IEEE Trans. Industrial Electronics*, vol. 67, no. 6, pp. 5115–5124, Jun. 2020.
- [6] J. Dai and D. C. Ludois, "A survey of wireless power transfer and a critical comparison of inductive and capacitive coupling for small gap applications," *IEEE Trans. Power Electronics*, vol. 30, no. 11, pp. 6017–6029, Nov. 2015.
- [7] X. Zhang, C. Xia, J. Luo, and Z. He, "Optimization and control of wireless power transfer system for electric vehicles," *IEEE Trans. Industrial Electronics*, vol. 67, no. 12, pp. 10929–10939, Dec. 2020.
- [8] H. H. Wu, A. Gilchrist, K. D. Sealy, and D. Bronson, "A review on inductive charging for electric vehicles," *IEEE Trans. Magnetics*, vol. 51, no. 6, pp. 1–10, Jun. 2015.
- [9] N. H. Chandra, M. B. Chhetri, S. Singh, and R. P. Agarwal, "Design and implementation of a solar-powered wireless charging system for electric vehicles," *IEEE Access*, vol. 9, pp. 55032–55042, Apr. 2021.
- [10] C. T. Rim, "Wireless power transfer systems for roadway-powered electric vehicles," *IEEE Transportation Electrification Council Newsletter*, Sept.–Oct. 2014.
- [11] Z. Zhang, H. Pang, A. Georgiadis, and C. Cecati, "Wireless power transfer – An overview," *IEEE Industrial Electronic Technology News (ITeN)*, 2020.
- [12] K. Fors, S. Linder, P. Stenumgaard, and K. Wiklundh, "Interference risks from wireless power transfer for electric vehicles," *IEEE EMC+SIPI*, 2021.
- [13] E. Koutroulis, K. Kalaitzakis, and N. C. Voulgaris, "Development of a microcontroller-based, photovoltaic maximum power point tracking control system," *IEEE Trans. Power Electronics*, vol. 16, no. 1, pp. 46–54, Jan. 2001.
- [14] D. P. Hohm and M. E. Ropp, "Comparative study of maximum power point tracking algorithms," *Progress in Photovoltaics: Research and Applications*, vol. 11, no. 1, pp. 47–62, Jan. 2003.
- [15] A. A. Hussein, A. M. Taha, K. H. Ahmed, M. A. Elgendy, and B. W. Williams, "Centralized control of electric vehicle charging stations for enhanced grid performance," *IEEE Trans. Industrial Electronics*, vol. 62, no. 12, pp. 7627–7637, Dec. 2015.
- [16] L. Ergene, M. Uzunoglu, and O. C. Onar, "A review of renewable energy-based electricity generation systems for electric vehicles," in *Proc. 2009 Int. Conf. Electrical and Electronics Engineering (ELECO)*, Bursa, Turkey, 2009, pp. 1–6.
- [17] D. Sera, R. Teodorescu, and P. Rodriguez, "PV panel model based on datasheet values," in *2007 IEEE Int. Symp. Industrial Electronics*, Vigo, Spain, 2007, pp. 2392–2396.
- [18] T. Esum and P. L. Chapman, "Comparison of photovoltaic array maximum power point tracking techniques," *IEEE Trans. Energy Conversion*, vol. 22, no. 2, pp. 439–449, Jun. 2007.
- [19] J. P. Ram, B. P. Kumar, and D. P. Kothari, "A novel P&O based algorithm for MPPT of coloured PV array," in *2014 Innovative Smart Grid Technologies Asia (ISGT ASIA)*, Kuala Lumpur, Malaysia, 2014, pp. 495–500.