

Development of Self-Regulating Irrigation System

Naresh Bhaiswar¹, Gaurav Kantode², Harshwardhan Bambal³, Harsh Bhagat⁴, Sakshi Chacherkar⁵,
Ansh Baisware⁶, Sarang Rahate⁷

¹ Research Scholar / Supervisor, Department of Mechanical Engineering, Priyadarshini College of Engineering, Nagpur, India

²⁻⁷ Undergraduate Students, Department of Mechanical Engineering, Priyadarshini College of Engineering, Nagpur, India

Abstract - The increasing demand for efficient water management in agriculture has led to the development of intelligent irrigation systems. This paper presents a self-regulating irrigation system that automates water supply based on real-time soil and environmental conditions. The system utilizes soil moisture, temperature, and humidity sensors to continuously monitor field parameters. A microcontroller processes the sensor data and compares it with predefined threshold values to control irrigation through a water pump and solenoid valve. The system operates only when required, thereby minimizing water wastage and reducing human intervention. Experimental analysis demonstrates that the system responds rapidly to variations in soil moisture and maintains optimal conditions for crop growth. The integration of environmental parameters enhances decision-making accuracy and overall system efficiency. The proposed system is cost-effective, reliable, and suitable for small and medium-scale agricultural applications. It contributes to sustainable farming practices by optimizing water usage and improving productivity.

Key Words: Irrigation System, Soil Moisture Sensor, Automation, Arduino, Smart Agriculture, Water Management.

1. INTRODUCTION

Agriculture is crucial for the growth and development of various economies worldwide, especially those that have a considerable percentage of their citizens engaged in agriculture. Water management is one of the essential elements that significantly affect the output of agricultural activities. Some of the common irrigation techniques include flood and spray irrigation. These methods cause the wastage of water through excess use, evaporation, and leakage.

In recent times, with the decreasing availability of water sources and erratic weather conditions, the requirement of an advanced irrigation system has become inevitable. The existing methods of irrigation are highly dependent on manual control and often tend to lead to either under-watering or over-watering of crops, which results in poor crop production. Thus, intelligent systems are required to optimize the irrigation process as per the changing environment.

Due to the development of sensing technologies, microcontrollers, and automation, an advanced irrigation system has been devised. With the help of such systems, one can monitor factors such as soil moisture, humidity, and temperature in real-time and make decisions accordingly with respect to irrigation processes.

The irrigation system developed in this study revolves around automation of the irrigation process based on real-time sensor data acquisition. In particular, such an irrigation system utilizes a microcontroller for processing sensor input and

controlling other hardware components like water pumps and solenoid valves. Such a system allows minimizing the need for human labor and makes irrigation more precise.

2. LITERATURE REVIEW

Efficient irrigation techniques have become the focus of many studies owing to the rising need for water conservation in agriculture. Irrigation techniques like flood, furrow, and basin irrigation were popular owing to their simplicity and cheapness. Nevertheless, these techniques have various shortcomings; first, water distribution is not even; second, they use too much water; third, they heavily depend on human labor. In addition, there is heavy loss of water through evaporation and runoff.

In order to tackle these problems, automated irrigation systems were developed that incorporate sensors, controllers, and actuators to control the irrigation process. These automated systems make use of soil moisture sensors that monitor the soil for moisture level. When the soil moisture falls below a certain level, irrigation takes place. This leads to efficient irrigation and better yields. Unfortunately, earlier automated irrigation systems lacked adaptability in changing environments.

Recent innovations have brought about sensor-controlled irrigation methods that take into account several environmental factors including temperature, humidity, and soil moisture. This technology enables improved decision-making based on actual data analysis, thus leading to increased accuracy in irrigation processes and reduced instances of water waste.

Moreover, IoT-powered smart irrigation systems have been adopted widely because of the remote management feature offered by these systems. Users are able to manage irrigation systems via mobile devices as well as cloud computing systems. However, some drawbacks associated with these irrigation systems include higher costs and dependence on steady internet connections.

Even with all the advancements made, there remain some areas that require further consideration. The majority of current irrigation technologies concentrate more on measuring soil moisture alone without the inclusion of other environmental conditions. Another problem lies in making use of such a technology that is costly, complicated to implement, and not scalable. Thus, an affordable and scalable irrigation system should be developed.

3. METHODOLOGY

The methodology adopted in the research work revolves around the development of an intelligent irrigation system, which is able to make decision autonomously according to environmental conditions. The methodology entails the use of sensors, embedded systems, and control techniques in order to

optimize the process. In contrast to regular irrigation systems, which follow predetermined schedules, the irrigation system being developed follows a variable schedule according to the needs of the field.

The intelligent irrigation system has been designed by adopting a feedback control system, which depends upon the input given from the environment for controlling the output of the system. This methodology will ensure the responsiveness of the system, as well as ensure that irrigation occurs when required and no unnecessary irrigation takes place.

3.1 SYSTEM DESIGN APPROACH

The system has been designed by combining various hardware components to form an integrated system, which can be used for automatic irrigation. It is designed in such a way that it is simple, reliable, and economical so that it can be implemented effectively in agriculture. The sensors have been installed in the soil and the surrounding environment to collect data, whereas the microcontroller has been programmed to process the data collected.

The system has been designed using a modular approach so that it can be easily modified and upgraded according to the needs of agriculture. All the components have been assigned specific tasks so that the system operates effectively.

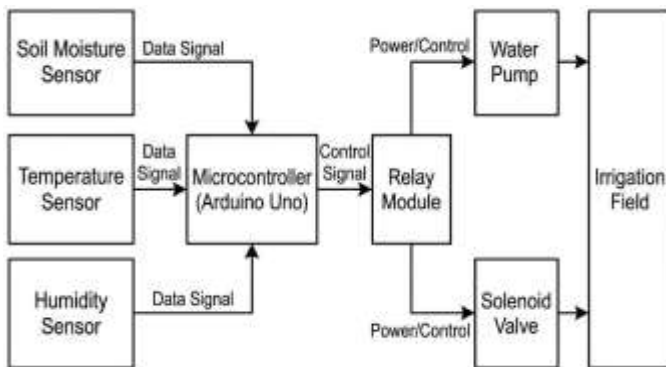

Fig -1: Block Diagram of Self-Regulating Irrigation System

The block diagram represents the overall architecture of the self-regulating irrigation system. It shows the interaction between sensors, microcontroller, and actuators for automated irrigation control.

3.2 SENSOR-BASED DATA ACQUISITION

Accurate data acquisition is fundamental to the proper functioning of the irrigation system. The sensors continuously monitor key parameters such as soil moisture, temperature, and humidity, which directly influence irrigation requirements. The placement of sensors plays a crucial role in ensuring reliable readings, especially the soil moisture sensor, which must be positioned within the root zone of the crops.

The collected data reflects real-time environmental conditions and provides the necessary input for decision-making. Continuous monitoring enables the system to detect even minor changes in soil moisture levels, ensuring timely irrigation. This real-time data acquisition improves the precision of the system and helps maintain optimal soil conditions for plant growth.

3.3 DATA PROCESSING AND INTELLIGENT DECISION MAKING

The microcontroller will then analyse the data generated from the sensors and transform the data into useful information. This will involve matching the readings of the sensors to predetermined threshold levels that will indicate the ideal soil moisture content. The process of decision-making will depend on the logic built into the system.

The adoption of intelligent decision-making helps to optimize the irrigation process through ensuring water is provided only when necessary. Over-irrigation and under-irrigation are prevented using such technology, thus making the irrigation system more efficient. Environmental changes will also not affect the irrigation process.

3.4 CONTROL AND ACTUATION MECHANISM

The control mechanism is responsible for executing the decisions made by the microcontroller. It involves the use of a relay module to control high-power devices such as the water pump and solenoid valve. The relay acts as an intermediary, allowing safe operation of electrical components.

When irrigation is required, the microcontroller sends a signal to activate the relay, which in turn starts the water pump and opens the solenoid valve. Once the desired soil moisture level is achieved, the system automatically stops irrigation. This automated control ensures precise water delivery and efficient system operation.

3.5 ALGORITHMIC IMPLEMENTATION

The system operates based on a continuous monitoring algorithm that ensures real-time responsiveness. The algorithm begins with system initialization, followed by sensor data acquisition and comparison with threshold values. Based on the result, appropriate control actions are taken.

The cyclic nature of the algorithm allows the system to operate continuously without interruption. This ensures that the irrigation process is always aligned with current environmental conditions. The algorithm is simple yet effective, making the system reliable and easy to implement.

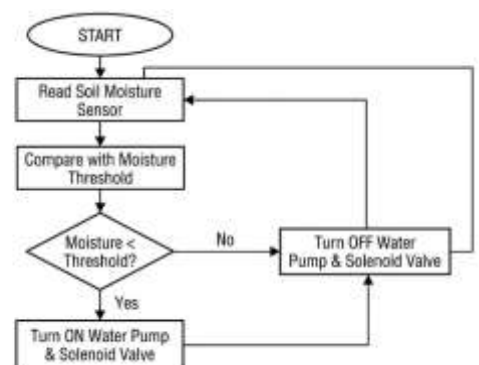

Fig -2: Flowchart of Irrigation Control Algorithm

The flowchart illustrates the decision-making process of the irrigation system based on soil moisture levels. It depicts how the system automatically turns irrigation ON or OFF.

3.6 CALIBRATION AND SYSTEM VALIDATION

Calibration is essential to ensure that sensor readings are accurate and consistent. The system is calibrated under different soil conditions to determine appropriate threshold values for irrigation. Proper calibration improves the accuracy of decision-making and enhances system performance.

Testing is conducted under various environmental conditions to evaluate system reliability and responsiveness. The results confirm that the system performs effectively in maintaining soil moisture levels and responds quickly to changes in environmental parameters. This validation ensures that the system is suitable for practical agricultural applications.

3.7 METHODOLOGICAL SIGNIFICANCE

The proposed methodology offers a practical solution to the challenges associated with traditional irrigation systems. By combining real-time monitoring with automated control, the system ensures efficient water usage and improved crop productivity. The methodology is designed to be scalable and adaptable, making it suitable for different types of agricultural environments.

Furthermore, the system promotes sustainable farming practices by conserving water resources and reducing energy consumption. The integration of multiple sensors enhances the accuracy of the system, while the use of simple control logic ensures ease of implementation. Overall, the methodology provides a balanced approach between performance, cost, and reliability.

4. COMPONENT SELECTION AND IMPLEMENTATION

The implementation of the self-regulating irrigation system involves the careful selection and integration of hardware components to achieve efficient and automated irrigation. The system is designed by considering factors such as accuracy, reliability, cost-effectiveness, and compatibility among components. The overall architecture combines sensing, processing, and actuation units, which work together to monitor environmental conditions and control water supply accordingly. This integrated approach ensures that the system operates smoothly and delivers optimal performance under varying agricultural conditions.

The microcontroller serves as the core component of the system, acting as the central processing unit that manages all operations. It receives input signals from various sensors, processes the data, and generates appropriate control signals for irrigation. The use of a programmable microcontroller allows flexibility in system design and enables easy modification of control logic based on different requirements. Its ability to perform real-time data processing ensures quick response to changes in soil and environmental conditions, making the system highly efficient and reliable.

The soil moisture sensor plays a crucial role in determining the irrigation requirement by measuring the water content present in the soil. It operates by detecting changes in electrical properties, which vary with moisture levels. The sensor continuously sends data to the microcontroller, allowing it to assess whether irrigation is needed. Proper placement of the sensor within the root zone is essential for accurate readings, as it directly reflects the moisture available to plants. This component significantly contributes to reducing water wastage and maintaining optimal soil conditions.

In addition to soil moisture sensing, environmental parameters such as temperature and humidity are also monitored to enhance decision-making. Temperature affects the rate of evaporation, while humidity influences the retention

of moisture in the soil. By incorporating these parameters, the system gains a more comprehensive understanding of environmental conditions, leading to more precise irrigation control. This multi-parameter monitoring improves system efficiency and ensures that irrigation is aligned with actual crop requirements.

The actuation mechanism of the system includes a relay module, water pump, and solenoid valve, which work together to control the flow of water. The relay module acts as an interface between the microcontroller and high-power devices, enabling safe switching operations. When irrigation is required, the microcontroller activates the relay, which in turn starts the water pump and opens the solenoid valve. Once the desired moisture level is achieved, the system automatically stops the irrigation process, ensuring precise water delivery and energy efficiency.

The successful implementation of the system depends on proper integration of all components and reliable system configuration. Sensors are connected to the input ports of the microcontroller, while actuators are controlled through output signals via the relay module. Adequate power supply and proper wiring are maintained to ensure safe operation and avoid system failures. After integration, the system is tested under different conditions to validate its performance. The results demonstrate that the system operates effectively, providing automated and efficient irrigation with minimal human intervention.

Table -1: Component Specifications

Component	Specification	Function
Arduino Uno	ATmega328P, 5V	Processing and control unit
Soil Moisture Sensor	Capacitive type	Measures soil moisture
DHT11 Sensor	Temp & Humidity sensor	Measures environmental conditions
Relay Module	5V, Single channel	Controls pump and valve
Water Pump	12V DC	Supplies water
Solenoid Valve	12V DC	Controls water flow

The table presents the list of hardware components used in the irrigation system along with their specifications and functional roles. It includes key elements such as the microcontroller, sensors, relay module, water pump, and solenoid valve. Each component is selected based on compatibility, efficiency, and reliability for system operation. The specifications help in understanding the technical configuration of the system. Overall, the table provides a clear overview of how different components contribute to the working of the irrigation system.

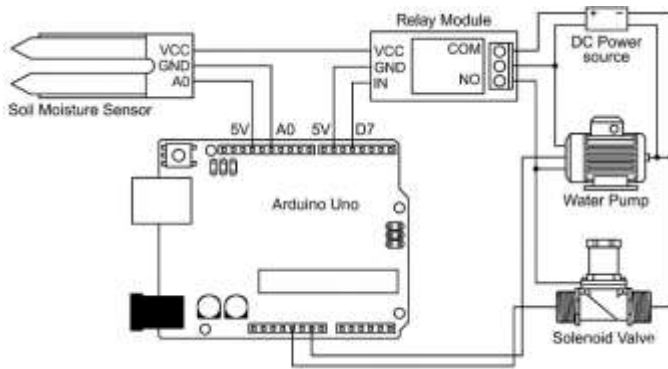

Fig -3: Hardware Setup of Irrigation System

The hardware diagram shows the interconnection of sensors, Arduino Uno, relay module, water pump, and solenoid valve forming the complete irrigation system. It illustrates how sensor inputs are processed by the microcontroller to control water flow automatically through actuators.

5. RESULTS AND DISCUSSION

The performance of the self-regulating irrigation system was evaluated through a series of experiments conducted under different soil moisture and environmental conditions. The system was tested to analyze its response, accuracy, and efficiency in maintaining optimal soil moisture levels. The experimental setup included sensors placed in the soil and environment, along with a microcontroller-based control unit connected to a water pump and solenoid valve. The observations were recorded systematically to assess system behavior under real-time conditions.

The results indicate that the system responds effectively to variations in soil moisture levels. When the moisture content drops below the predefined threshold, the system activates irrigation automatically. Conversely, when the soil moisture reaches the desired level, the system turns off the irrigation process. This demonstrates the ability of the system to operate autonomously and maintain soil moisture within the required range, thereby preventing both over-irrigation and under-irrigation.

Table -2: Experimental Data of Soil Moisture, Temperature and Irrigation Status

Time (min)	Soil Moisture (%)	Temperature (°C)	Irrigation Status
0	35	25	OFF
5	32	26	OFF
10	28	27	OFF
15	24	28	ON
20	30	29	ON
25	36	30	OFF

The table presents recorded values of soil moisture, temperature, and irrigation status over time. It is used to analyze system behavior under different conditions.

The graphical analysis of soil moisture versus time shows a gradual decrease in moisture due to natural factors such as evaporation and plant absorption. Once the moisture level falls below the threshold value, irrigation is triggered, resulting in a rapid increase in soil moisture. This behavior confirms that the system is capable of detecting critical moisture levels and responding promptly. The graph clearly illustrates the effectiveness of the control mechanism in maintaining soil conditions.

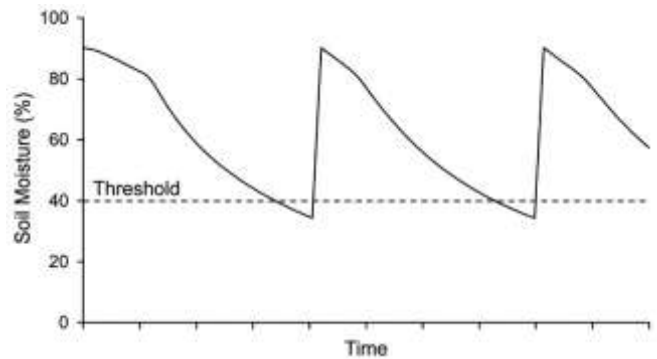

Fig -3: Soil Moisture vs Time

The soil moisture sensor measures the water content present in the soil. It provides real-time data to determine the need for irrigation.

The irrigation status versus time graph further validates system performance by showing clear ON and OFF states corresponding to soil moisture conditions. The irrigation system remains inactive when the moisture level is above the threshold and activates only when necessary. This controlled operation ensures efficient water usage and eliminates unnecessary irrigation cycles, contributing to resource conservation.

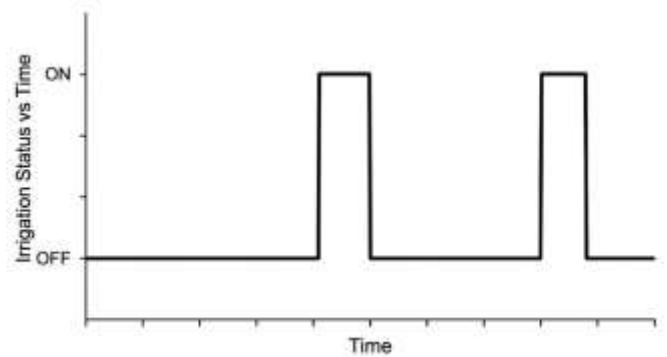

Fig -4: Irrigation Status vs Time

This graph represents the ON and OFF states of the irrigation system over time. It shows that irrigation is activated only when moisture falls below the threshold.

The analysis of temperature variation with respect to time indicates that increasing temperature leads to faster depletion of soil moisture due to higher evaporation rates. The system adapts to these changes by triggering irrigation more frequently under high-temperature conditions. The inclusion of environmental parameters such as temperature and humidity enhances the decision-making capability of the system and improves overall performance.

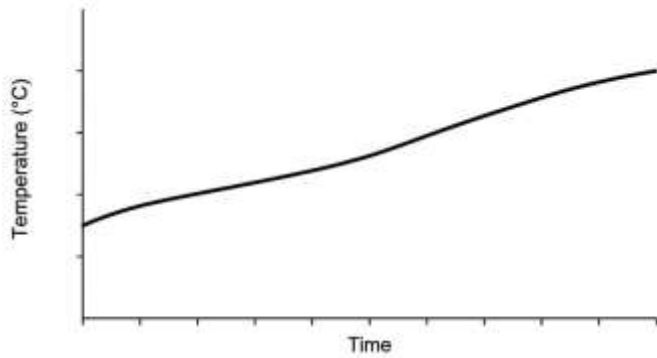

Fig -5: Temperature vs Time

The graph shows how temperature changes over time during observation. It helps analyse the effect of temperature on soil moisture and irrigation needs.

Overall, the experimental results demonstrate that the proposed system is efficient, reliable, and capable of maintaining optimal soil moisture levels under varying environmental conditions. The system reduces water wastage, minimizes manual intervention, and ensures consistent irrigation performance. The findings confirm that the developed irrigation system is suitable for practical implementation in modern agricultural practices.

Table -3: System Performance Analysis

Parameter	Observation
Response Time	Fast (Immediate activation)
Water Efficiency	High (No wastage observed)
Accuracy	High (Threshold-based control)
Automation Level	Fully Automatic
Reliability	Consistent performance

The table summarizes the overall performance of the irrigation system. It highlights efficiency, accuracy, and reliability of the system.

6. CONCLUSION

The present study successfully demonstrates the design and implementation of a self-regulating irrigation system based on real-time monitoring of soil and environmental parameters. The system effectively utilizes sensors, a microcontroller, and automated control mechanisms to regulate irrigation according to actual field requirements. By operating on a threshold-based control strategy, the system ensures that water is supplied only when necessary, thereby reducing wastage and improving efficiency.

The experimental results confirm that the system responds quickly to variations in soil moisture and maintains optimal conditions for crop growth. The integration of temperature and humidity parameters further enhances the accuracy and adaptability of the system under different environmental conditions. The automated operation significantly reduces human intervention and ensures consistent performance.

Overall, the proposed system provides a cost-effective, reliable, and efficient solution for modern irrigation practices. It contributes to sustainable agriculture by optimizing water usage and improving crop productivity. The system is particularly suitable for small and medium-scale farming applications and has the potential for further enhancement through advanced technologies.

ACKNOWLEDGEMENT

The authors express their sincere gratitude to Mr. Naresh Bhaishwar, Research Scholar, for his valuable guidance, continuous support, and encouragement throughout the development of this work. His expertise and insights played a significant role in the successful completion of the project.

REFERENCES

- Samawi, V. W. (2021). Smcsis: An iot based secure multi-crop irrigation system for smart farming. *International Journal of Innovative Computing, Information and Control*, 17(4), 1225-1241.
- García, L., Parra, L., Jimenez, J. M., Lloret, J., & Lorenz, P. (2020). IoT-based smart irrigation systems: An overview on the recent trends on sensors and IoT systems for irrigation in precision agriculture. *Sensors*, 20(4), 1042.
- Sharma, V., Kaur, G., Chhabra, V., & Kashyap, R. (2025). Smart irrigation systems in agriculture: An overview. *Computers and Electronics in Agriculture*, 239, 111008.
- Obaideen, K., Yousef, B. A., AlMallahi, M. N., Tan, Y. C., Mahmoud, M., Jaber, H., & Ramadan, M. (2022). An overview of smart irrigation systems using IoT. *Energy Nexus*, 7, 100124.
- Gupta, S., Chowdhury, S., Govindaraj, R., Amesho, K. T., Shangdiar, S., Kadhila, T., & Iikela, S. (2025). Smart agriculture using IoT for automated irrigation, water and energy efficiency. *Smart Agricultural Technology*, 12, 101081.
- Zhang, Y., Wang, X., Jin, L., Ni, J., Zhu, Y., Cao, W., & Jiang, X. (2025). Research and development of an IoT smart irrigation system for farmland based on LoRa and edge computing. *Agronomy*, 15(2), 366.
- Mohiuddin, M., Islam, M. S., & Shanjida, S. (2024). Internet of Things (IoT)-Based Smart Agriculture Irrigation and Monitoring System Using Ubidots Server. *Engineering Proceedings*, 82(1), 99.
- Reddy, V. S., Harivardhagini, S., & Sreelakshmi, G. (2024). IoT and cloud based sustainable smart irrigation system. In *E3S Web of Conferences* (Vol. 472, p. 01026). EDP Sciences.
- Samawi, V. W. (2021). Smcsis: An iot based secure multi-crop irrigation system for smart farming. *International Journal of Innovative Computing, Information and Control*, 17(4), 1225-1241.
- Anitha, A., Sampath, N., & Jerlin, M. A. (2020, February). Smart irrigation system using Internet of Things. In *2020 international conference on emerging trends in information technology and engineering (ic-ETITE)* (pp. 1-7). IEEE.
- Sariki, R. K., Charishma, P. V. S., Moningi, R. K., Namana, M. S. K., Gandi, S. S. K., & Sathi, B. D. (2024, December). IoT-Based Smart Irrigation System with Cloud-Based Soil Monitoring. In *2024 2nd International Conference on Signal Processing, Communication, Power and Embedded System (SCOPES)* (pp. 1-4). IEEE.
- Gomathy, C. K., Vamsikumar, A., Karthik, B., & Purushothamreddy, A. (2021). The smart irrigation system using IoT. *Int. Res. J. Eng. Tech*, 8, 462-468.
- Radhika, R., Shobana, M., Balasaraswathi, V. R., Fancy, C., & Shamala, L. M. (2022, June). An automated irrigation system with movement and sound detection sensor for crop shielding. In *2022 7th International Conference on Communication and Electronics Systems (ICCES)* (pp. 38-44). IEEE.

14. Rathore, T., Gupta, D. K., & Kumar, N. (2023, May). Smart irrigation system using IoT. In 2023 Third International Conference on Secure Cyber Computing and Communication (ICSCCC) (pp. 605-610). IEEE.
15. Tephila, M. B., Sri, R. A., Abinaya, R., Lakshmi, J. A., & Divya, V. (2022, March). Automated smart irrigation system using IoT with sensor parameter. In 2022 international conference on electronics and renewable systems (ICEARS) (pp. 543-549). IEEE.
16. Patil, J. K., & Mandlik, V. S. (2025, October). Enhanced Soil Classification and Moisture Monitoring System Using Raspberry Pi 3B+ with IoT Integration. In 2025 IEEE DELCON-International Conference on Recent Smart Technologies in Engineering for Sustainable Development (pp. 1-5). IEEE.
17. Kumari, M., & Sah, A. K. (2021). IoT enabled smart irrigation system, monitoring and water harvesting in different soils. *International Journal of Engineering Research & Technology (IJERT)*, 10(3), 545-552.
18. Haq, M. A. (2024). Intelligent sustainable agricultural water practice using multi sensor spatiotemporal evolution. *Environmental Technology*, 45(12), 2285-2298.
19. Mezouari, A. E., Fazziki, A. E., & Sadgal, M. (2021). Towards smart farming through machine learning-based automatic irrigation planning. In *Smart sensor networks: Analytics, sharing and control* (pp. 179-206). Cham: Springer International Publishing.
20. ME, S. V. (2020). An IOT based smart irrigation system using soil moisture and weather prediction. *International Journal of Engineering Research & Technology (IJERT), ECLECTIC*.