

# HAND GESTURE CONTROL ROBO CAR USING MACHINE LEARNING

Mr. G V S BHARADWAJ<sup>1</sup>, U. Greeshma<sup>2</sup>, P. Badulla<sup>3</sup>, V. Vinod Kumar<sup>4</sup>, CH. MadhuSudhan<sup>5</sup>, V. Sravan kumar<sup>6</sup>

<sup>1</sup>Assistant Professor, Dept of ECE, PBR VITS, Kavali, Andhra Pradesh, India.

<sup>2,3,4,5,6</sup> Students of Department of Electronics and Communication Engineering,  
PBR Visvodaya Institute of Technology & Science, Kavali (Autonomous),  
SPSR Nellore (Dt.), Andhra Pradesh – 524201, India

\*\*\*

**Abstract** - The Hand Gesture Control Robo Car is an innovative system designed to enable contactless control through intuitive hand gestures. It addresses the limitations of traditional control methods by improving user convenience, accessibility, and safety. The system is built around a Raspberry Pi, which functions as the central processing unit. A camera captures real-time hand movements, and a machine learning model interprets these gestures into control commands. Commands such as forward, backward, left, right, and stop are accurately recognized. These instructions are transmitted to a motor driver to control the DC motors. This ensures smooth and precise movement of the robotic vehicle. The system also integrates a MEMS sensor to detect vibrations or abnormal conditions. In emergency situations, alerts are generated through audio, Email, or Telegram. Overall, the project demonstrates an efficient integration of machine learning and embedded systems for smart and safe robotic control.

**Key Words:** Hand Gesture Recognition, Machine Learning, Raspberry Pi, Robotic Car, Computer Vision, MEMS Sensor, Human–Machine Interaction.

\*\*\*

## 1. INTRODUCTION

Recent advancements in artificial intelligence, machine learning, and robotics have enabled the development of intuitive human–machine interaction systems. The Hand Gesture Control Robo Car allows users to control a robotic vehicle using simple hand movements, eliminating the need for traditional controllers such as buttons or joysticks. A camera or sensors capture real-time gestures, and machine learning algorithms recognize commands like forward, backward, left, and right, which are then converted into control signals for the car. This technology has wide applications in assistive systems, automation, and robotics, offering a more natural and contactless mode of interaction. It enhances user convenience, safety, and hygiene by reducing physical contact with devices. Overall, the Hand Gesture Control Robo Car demonstrates an effective integration of computer vision, machine learning, and embedded systems to create a smart, efficient, and user-friendly robotic control system.

## 2. LITERATURE SURVEY

**R1:** This project develops a gesture-controlled robotic car using machine learning for intuitive human–robot interaction with high accuracy. It also includes Bluetooth communication and a robotic arm for flexible operation.

**R2:** This work presents an AI-based robotic system for real-time object detection and autonomous navigation. It is designed for applications in logistics, automation, security, and healthcare.

**R3:** This study focuses on vision-based hand gesture recognition for natural human–robot interaction. It highlights key processes and challenges in improving accuracy and reliability.

**R4:** This paper introduces a YOLOv5s-based gesture recognition system for real-time vehicle control. It achieves high accuracy with low latency using Raspberry Pi and a web interface.

**R5:** This project develops a gesture-controlled smart wheelchair using deep learning on Jetson Nano. It improves mobility and independence for disabled individuals.

### 3. EXISTING SYSTEM

The existing model of the Hand Gesture Control Robo Car is mainly based on traditional control methods and basic gesture recognition techniques. Earlier systems relied on physical controllers such as joysticks, remote controls, or wired interfaces, which limited user convenience. Some approaches used sensors like accelerometers or wearable gloves to detect hand movements, requiring users to wear additional devices and reducing flexibility. Vision-based systems were also developed, but they often depended on simple rule-based algorithms, resulting in low accuracy and slow response times.

These systems also faced challenges in handling varying lighting conditions and complex backgrounds, affecting their performance and reliability. Communication methods like Bluetooth were used but had limited range and stability. Additionally, most existing models lacked advanced safety features such as accident detection and alert systems. Overall, these limitations made existing systems less efficient, less adaptable, and less user-friendly compared to modern machine learning-based solutions.

In addition to these drawbacks, many traditional systems lacked the ability to learn and improve over time, making them less adaptable to new environments and user behaviors. They were also limited in processing real-time data efficiently, which affected the smooth operation of the robo car. Furthermore, the absence of integration with modern technologies such as IoT and cloud-based monitoring restricted their potential for advanced applications and remote accessibility.

### 4. PROPOSED SYSTEM

The proposed system is designed to develop a Hand Gesture Control Robo Car using machine learning and computer vision techniques for intuitive and contactless operation. The system utilizes a Raspberry Pi as the central processing unit, which processes input from a camera to capture real-time hand gestures. MediaPipe is employed to detect and track hand landmarks, enabling accurate recognition of gestures such as forward, backward, left, right, and stop. These recognized gestures are then converted into control commands and transmitted to a motor driver, which controls the movement of DC motors for smooth navigation of the robotic car.

In addition to gesture-based control, the system incorporates safety features using MEMS sensors to detect abnormal conditions such as vibrations or accidents. Upon detecting an emergency or specific gesture, the system triggers alert mechanisms including audio notifications and messages via Email and Telegram to predefined contacts. The use of MediaPipe ensures high accuracy and low latency, while its modular architecture allows easy customization and integration. Overall, the proposed system offers a reliable, efficient, and user-friendly solution for robotic control, with potential applications in automation, assistive technologies, and advanced robotics.

Furthermore, the system is designed to be cost-effective and easily scalable, making it suitable for both academic and practical applications. Its modular design allows future enhancements such as integration with IoT platforms, voice control, or advanced AI models for improved gesture recognition. The flexibility and adaptability of the system make it capable of operating in various environments with minimal modifications. Hence, the proposed system represents a significant step toward the development of smart and intelligent robotic systems.

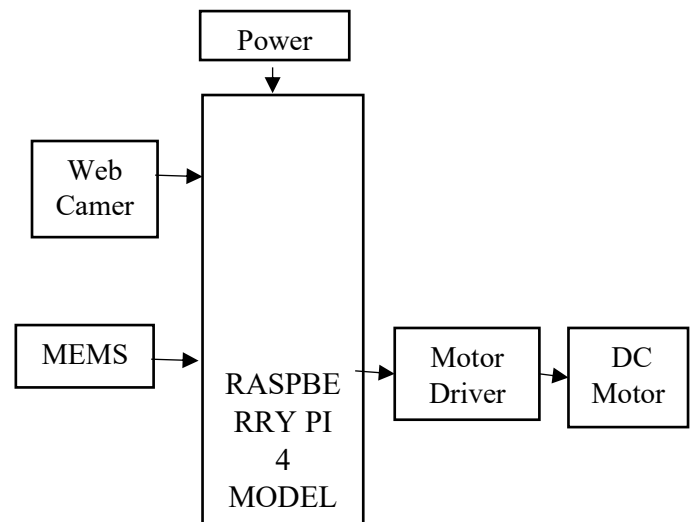

Fig 1: Block diagram of Hand Gesture Control Robo Car Using Machine Learning

## 5. IMPLEMENTATION AND RESULTS

The hardware setup of the Hand Gesture Control Robo Car is centered around a Raspberry Pi, which acts as the main processing unit. A web camera is connected to the Raspberry Pi to capture real-time hand gestures from the user. The captured video is processed to recognize gestures and convert them into control commands. A motor driver module is interfaced with the Raspberry Pi to control the DC motors attached to the wheels, enabling movement of the robotic car in different directions.



Fig 2: Hardware set up of proposed system

The system is powered by a battery supply, ensuring portability and continuous operation. All components are interconnected using wiring for power and signal transmission. Additional components such as a MEMS sensor can be integrated to detect vibrations or abnormal conditions for safety purposes. The entire setup is mounted on a chassis, forming a compact and efficient robotic system capable of gesture-based control.

In Figure 3 Gesture 1 represents the forward movement command of the robo car. In this gesture, the user typically moves their hand forward (away from the body) or shows an open palm facing outward.

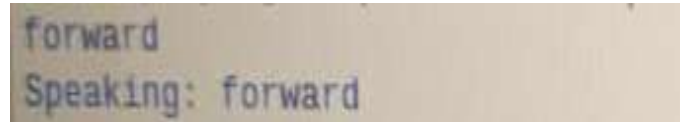

Fig 3: Robo Car Movement Directive

## 6. DISCUSSION

The Hand Gesture Control Robo Car project demonstrates an effective approach to intuitive and contactless human-machine interaction. By integrating computer vision and machine learning techniques, the system accurately recognizes hand gestures in real time and converts them into movement commands for the robotic car. The use of Raspberry Pi ensures compact design and efficient processing, while MediaPipe enhances gesture detection with high accuracy and low latency. This results in a smooth, user-friendly control system compared to traditional methods.

The project also improves safety and functionality through the inclusion of MEMS sensors and emergency alert features such as Email and Telegram notifications. However, performance may be affected by factors like poor lighting, complex backgrounds, and hardware limitations. Despite these challenges, the system shows strong potential for applications in automation, assistive technologies, and robotics. Future improvements can focus on increasing accuracy, reducing delays, and expanding gesture recognition capabilities.

## 7. CONCLUSION

The Hand Gesture Control Robo Car Using Machine Learning project successfully demonstrates an intelligent and contactless approach to robotic vehicle control by integrating real-time gesture recognition with embedded processing. By utilizing a Raspberry Pi and Media Pipe-based hand tracking, the system accurately interprets human gestures and converts them into precise motor control commands, ensuring smooth and responsive navigation. The addition of a MEMS-based accident detection mechanism and emergency gesture-triggered alerts further enhances the safety and practical applicability of the system. This project not only eliminates the dependency on conventional remote controllers but also promotes natural human-robot interaction, adaptability, and automation. Overall, the system proves to be efficient, user-friendly, and scalable, making it highly suitable for assistive robotics, smart surveillance, defense applications, and future AI-driven control systems.

## 8. REFERENCE

- [1] MobileNets: Efficient Convolutional Neural Networks for Mobile Vision Applications
- [2] A. G. Howard *et al.*, "MobileNets: Efficient Convolutional Neural Networks for Mobile Vision Applications," 2017.
- [3] ImageNet: A Large-Scale Hierarchical Image Database  
J. Deng, W. Dong, R. Socher, L.-J. Li, K. Li, "ImageNet: A Large-Scale Hierarchical Image Database," *Proc. IEEE CVPR*, 2009.
- [4] J. L. Raheja, R. Shyam, U. Kumar, P. B. Prasad, "Real-Time Robotic Hand Control using Hand Gestures," *Proc. Int. Conf. Machine Learning and Computing*, 2010.
- [5] P. B. Nayana, S. Kubakaddi, "Implementation of Hand Gesture Recognition Technique for HCI Using OpenCV," *Int. Journal of Recent Developments*, vol. 2, no. 5, pp. 17–21, 2014.
- [6] M. K. Ahuja, A. Singh, "Static Vision-Based Hand Gesture Recognition Using PCA," *Proc. IEEE Int. Conf. MOOCs, Innovation and Technology in Education (MITE)*, 2015.
- [7] L. Bretzner, I. Laptev, T. Lindeberg, "Hand Gesture Recognition Using Multi-Scale Colour Features and Particle Filtering," *Proc. IEEE Int. Conf. Automatic Face and Gesture Recognition*, 2002.
- [8] F. S. Chen, C. M. Fu, C. L. Huang, "Hand Gesture Recognition Using a Real-Time Tracking Method and Hidden Markov Models," *Image and Vision Computing*, vol. 21, no. 8, pp. 745–758, 2003.
- [9] A. K. Kyaw, J. J. Joseph, H. P. Truong, "Low-Cost Computing Using Raspberry Pi 2 Model B," 2017.
- [10] F. T. Liu, Y. T. Wang, H. P. Ma, "Handwriting Recognition Using Wearable 9-Axis Sensors," 2017.
- [11] R. Mardiyanto, H. Suryoatmojo, "Development of Hand Gesture Recognition Sensor Based on Underwater Remotely Operated Robots," 2017.
- [12] G. Marqués, K. Basterretxea, "Efficient Algorithms for Accelerometer-Based Wearable Hand Gesture Recognition Systems," *IEEE*, 2015.