

Improvement of Power Quality Using ANN Based Dynamic Voltage Restorer

Dr K Manoz kumar Reddy¹, Adabala Swamy², Sheik Mubaina³, Y B Vijay⁴, Y Pavan Sankar⁵

Associate Professor of EEE department, Aditya College of Engineering & Technology, Surampalem, A.P, India.¹

B.Tech Scholar, Aditya College of Engineering & Technology, Surampalem, A.P, India.^{2,3,4,5}

Abstract- *In the power system, power quality is a crucial issue that impacts customers and services. Numerous issues arise in the current electric power system as a result of the integration of renewable energy sources, smart grid systems, and the significant use of power electronics equipment. Harmonics, voltage sags, and swells have the potential to harm delicate equipment. These devices are vulnerable to changes in input voltage caused by interference with other system components. Power quality is therefore crucial for the dependable and secure operation of power systems in the modern era due to the development of conscious and costly electronic equipment. A potential Distribution Flexible AC Transmission System (D-FACTS) tool that is frequently used to overcome irregular voltage, current, or frequency issues in the distribution grid is the Dynamic Voltage Restorer (DVR). The voltage profile and a steady voltage on the load are preserved by injecting voltages into the distribution line. To demonstrate the efficacy of the DVR-based suggested strategy in reducing the distorted voltage caused by harmonics, simulations were carried out in MATLAB/Simulink. This project uses an Artificial Neural Network (ANN) controller to lower the total harmonic distortion. It has been observed that a smooth indemnified load voltage was achieved and that the suggested DVR-based approach successfully controlled voltage distortion.*

Index Terms—Dynamic voltage restorer (DVR), artificial neural networks (ANN), power quality, unit vector, voltage harmonics, voltage sag, voltage swells.

I. INTRODUCTION

POWER QUALITY problems in the present-day distribution systems are consigned in the literature due to the increased use of sensitive and demanding equipment such as communication chain, process industries, and decisive construction processes. Power quality problems like transients, sags, swells, also alternative distortions to the sinusoidal waveform of the supply voltage disturb the performance of these equipment pieces. Technologies like custom power devices are developed to provide protection in contrast to power quality complications. Custom power devices are usually of three categories like series-connected compensators known as dynamic voltage restorers (DVRs), shunt-connected compensators like distribution static

compensators, and a combination of series and shunt-connected compensators owns unified power quality conditioners. The DVR can regulate the load voltage from the problems like sag, swell, and harmonics in the supply voltages. Hence, it can defend the critical consumer loads from tripping and consequent losses. The custom power devices are advanced and inaugurated at consumer point to meet the power quality standards such as IEEE-519.

Voltage sags in an electrical grid are not always possible to avoid because of the finite clearing time of the faults that cause the voltage sags and the reproduction of sags from the transmission and distribution systems to the low-voltage loads. Voltage sags are the accepted reasons for discontinuance in production plants and for end-user equipment defects in general. In particular tripping of equipment in a production line can cause production blackouts and significant costs due to loss of production. One solution to this complication is to make the equipment itself more permissive to sags, either by intelligent control or by storing “ride-through” energy in the equipment. An alternative solution, on the contrary modifying each component in a plant to be progressive against voltage sags, is to install a plant wide incorruptible power supply system for longer power rupture or a DVR on the incoming supply to reduce voltage sags for shorter periods. DVRs can eradicate most of the sags and diminish the risk of load tripping for very deep sags, but their main defects are their standby losses, the equipment cost, and also the conservation scheme required for ensuing short circuits.

Many solutions and their complications using DVRs are announced, such as the voltages in a three-phase system are stabilized and an energy-optimized control of DVR is analyzed. Industrial examples of DVRs are given in, and distinct control methods are discussed for distant types of voltage sags. An observation of different topologies and control methods is presented for a DVR. The arrangement of a capacitor-supported DVR that assure sag, swell, distortion, or unbalance in the supply voltages is concluded. The execution of a DVR with the high-frequency-link transformer is explained. In this paper, the control and act of a DVR are endorsed with a reduced-rating Voltage-Source-Converter

(VSC) with ANN controller. The synchronous-Reference-Frame (SRF) theory is used for the regulation of the DVR.

II. OPERATION OF DVR

The schematic of a DVR-connected system is shown in Fig. 1(a). The voltage V_{inj} is inserted such that the load voltage V_{load} is constant in magnitude and is undistorted, although the supply voltage V_s is not constant in magnitude or is distorted.

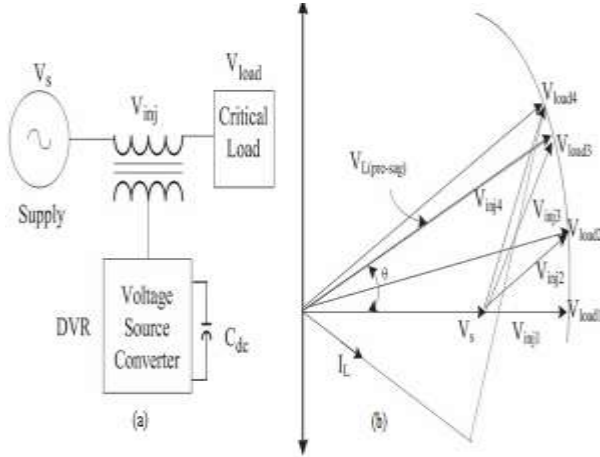

Fig. 1. (a) Basic circuit of DVR. (b) Phasor diagram of the DVR voltage injection schemes.

Fig. 1(b) shows the phasor diagram of different voltage injection schemes of the DVR. $V_L(\text{pre-sag})$ is a voltage across the critical load prior to the voltage sag condition. During the voltage sag, the voltage is reduced to V_s with a phase lag angle of θ . Now, the DVR injects a voltage such that the load voltage magnitude is maintained at the pre-sag condition. According to the phase angle of the load voltage, the injection of voltages can be realized in four ways. V_{inj1} represents the voltage injected in-phase with the supply voltage. With the injection of V_{inj2} , the load voltage magnitude remains same but it leads V_s by a small angle. In V_{inj3} , the load voltage retains the same phase as that of the pre-sag condition, which may be an optimum angle considering the energy source. V_{inj4} is the condition where the injected voltage is in quadrature with the current, and this case is suitable for a capacitor-supported DVR as this injection involves no active power.

However, a minimum possible rating of the converter is achieved by V_{inj1} . The DVR is operated in this scheme with a battery energy storage system (BESS). Fig. 2 shows a schematic of a three-phase DVR connected to restore the voltage of a three-phase critical load. A three-phase supply is connected to a critical and sensitive load through a three-phase series injection transformer.

The equivalent voltage of the supply of phase A v_{Ma} is connected to the point of common coupling (PCC) v_{Sa} through short-circuit impedance Z_{sa} . The voltage injected by the DVR in phase. A v_{Ca} is such that the load voltage v_{La} is of rated magnitude and undistorted. A three-phase DVR is connected to the line to inject a voltage in series using three single-phase transformers T_r . L_r and C_r represent the filter components used to filter the ripples in the injected voltage.

A three-leg VSC with insulated-gate bipolar transistors (IGBTs) is used as a DVR, and a BESS is connected to its dc bus.

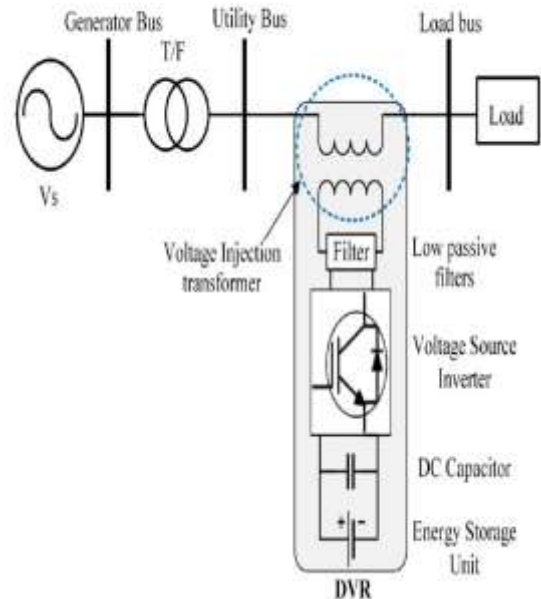

Fig2. Basic Configuration of DVR.

III. CONTROL OF DVR

The compensation for voltage sags using a DVR can be performed by injecting or absorbing the reactive power or the real power. When the injected voltage is in quadrature with the current at the fundamental frequency, the compensation is made by injecting reactive power and the DVR is with a self-supported dc bus. However, if the injected voltage is in phase with the current, DVR injects real power, and hence, a battery is required at the dc bus of the VSC. The control technique adopted should consider the limitations such as the voltage injection capability (converter and transformer rating) and optimization of the size of energy storage.

A. Control of DVR with BESS for Voltage Sag, Swell, and Harmonics Compensation

Fig. 3 shows a control block of the DVR in which the SRF theory with artificial neural networks (ANN) is used for reference signal estimation. The voltages at the PCC v_s and at the load terminal v_L are sensed for deriving the IGBTs' gate signals. The reference load voltage V^*_L is extracted using the derived unit vector. Load voltages (V_{La} , V_{Lb} , V_{Lc}) are converted to the rotating reference frame using abc-dqo conversion using Park's transformation with unit vectors ($\sin, \theta, \cos, \theta$) derived using a phase-locked loop as

$$\begin{bmatrix} v_{Lq} \\ v_{Ld} \\ v_{L0} \end{bmatrix} = \frac{2}{3} \begin{bmatrix} \cos \theta & \cos(\theta - \frac{2\pi}{3}) & \cos(\theta + \frac{2\pi}{3}) \\ \sin \theta & \sin(\theta - \frac{2\pi}{3}) & \sin(\theta + \frac{2\pi}{3}) \\ \frac{1}{2} & \frac{1}{2} & \frac{1}{2} \end{bmatrix} \begin{bmatrix} v_{Laref} \\ v_{Lbref} \\ v_{Lcref} \end{bmatrix}$$

(1)

Similarly, reference load voltages (V^*La, V^*Lb, V^*Lc) and voltages at the PCC v_S are also converted to the rotating reference frame. Then, the DVR voltages are obtained in the rotating reference frame as

$$v_{Dd} = v_{Sd} - v_{Ld} \tag{2}$$

$$v_{Dq} = v_{Sq} - v_{Lq} \tag{3}$$

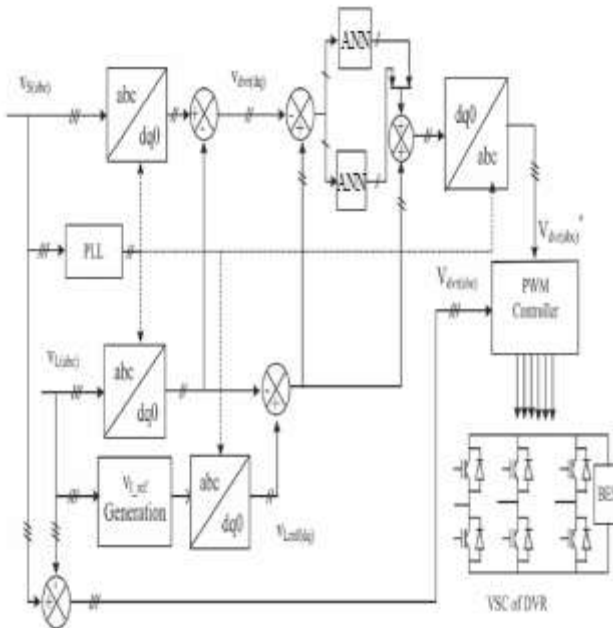

Fig. 3. Control block of the DVR that uses the Artificial neural network

The reference DVR voltages are obtained in the rotating reference frame as

$$v_{Dd}^* = v_{Sd}^* - v_{Ld} \tag{4}$$

$$v_{Dq}^* = v_{Sq}^* - v_{Lq} \tag{5}$$

The error between the reference and actual DVR voltages in the rotating reference frame is regulated using two artificial neural network (ANN) controllers. Reference DVR voltages in the abc frame are obtained from a reverse Park's transformation taking V^*Dd from (4), V^*Dq from (5), V^*D0 as zero as

$$\begin{bmatrix} v_{dvra}^* \\ v_{dvrb}^* \\ v_{dvrc}^* \end{bmatrix} = \begin{bmatrix} \cos \theta & \sin \theta & 1 \\ \cos(\theta - \frac{2\pi}{3}) & \sin(\theta - \frac{2\pi}{3}) & 1 \\ \cos(\theta + \frac{2\pi}{3}) & \sin(\theta + \frac{2\pi}{3}) & 1 \end{bmatrix} \begin{bmatrix} v_{Dq}^* \\ v_{Dd}^* \\ v_{D0}^* \end{bmatrix} \tag{6}$$

Reference DVR voltages ($v_{dvra}^*, v_{dvrb}^*, v_{dvrc}^*$) and actual DVR voltages ($v_{dvra}, v_{dvrb}, v_{dvrc}$) are used in a pulse width modulated (PWM) controller to generate gating pulses to a VSC of the DVR. The PWM controller is operated with a switching frequency of 10 kHz.

B. Control of Self-Supported DVR for Voltage Sag, Swell, and Harmonics Compensation

Fig. 4(a) shows a schematic of a capacitor-supported DVR connected to three-phase critical loads, and Fig. 4(b) shows a control block of the DVR in which the SRF theory is used for the control of self-supported DVR. Voltages at the PCC v_S are converted to the rotating reference frame using $abc-dq0$ conversion using Park's transformation. The harmonics and the oscillatory components of the voltage are eliminated using low pass filters (LPFs). The components of voltages in the d - and q -axes are

$$v_d = v_{d dc} + v_{d ac} \tag{7}$$

$$v_q = v_{q dc} + v_{q ac} \tag{8}$$

The compensating strategy for compensation of voltage quality problems considers that the load terminal voltage should be of rated magnitude and undistorted.

IV. Artificial neural networks (ANN)

Neural networks consist of a large class of different architectures. In many cases, the issue is approximating a static nonlinear, mapping $f(x)$ with a neural network $f_{NN}(x)$, where $x \in R^K$.

The most useful neural networks in function approximation are Multilayer Layer Perceptron (MLP) and Radial Basis Function (RBF) networks. Here we concentrate on MLP networks. A MLP consists of an input layer, several hidden layers, and an output layer. Node i , also called a neuron, in a MLP network is shown in Fig. 5. It includes a summer and a nonlinear activation function g .

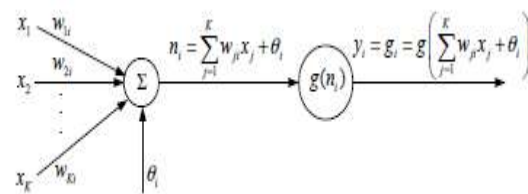

Fig.4. Single node in a MLP network.

The inputs x_1, \dots, x_k are multiplied by weights w_{ki} and summed up together with the constant bias term θ_i . The resulting n_i is the input to the activation function g . The activation function was originally chosen to be a relay function, but for mathematical convenience a hyperbolic tangent (\tanh) or a sigmoid function are most commonly used. Hyperbolic tangent is defined as

$$\tanh(x) = \frac{1 - e^{-x}}{1 + e^{-x}} \tag{9}$$

The output of node i becomes

$$y_i = g_i = g \left(\sum_{j=1}^K w_{ji} x_j + \theta_i \right) \tag{10}$$

Connecting several nodes in parallel and series, a MLP network is formed. A typical network is shown in Fig. 6.

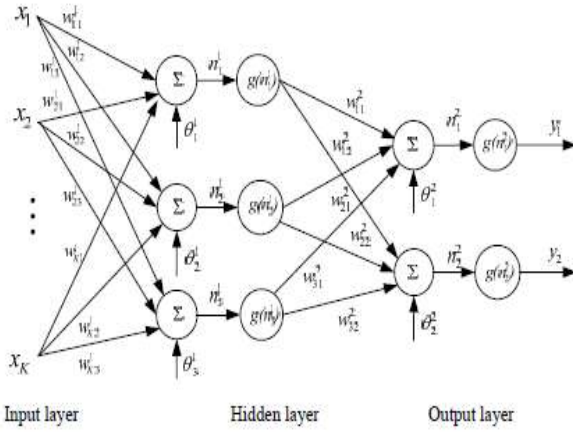

Fig. 5. A multilayer perceptron network with one hidden layer.

Here the same activation function g is used in both layers. The superscript of n , θ , or w refers to the layer, first or second. The output y_i , $i=1, 2$ of the MLP network becomes

$$y_i = g \left(\sum_{j=1}^s w_{ji} g \left(\sum_{k=1}^K w_{kj} x_k + \theta_j \right) + \theta_i \right) \tag{11}$$

From (3) we can conclude that a MLP network is a nonlinear parameterized map from input space $\mathbf{x} \in \mathbb{R}^x$ to output space $\mathbf{y} \in \mathbb{R}^m$ here ($m=3$). Activation functions g are usually assumed to be the same in each layer and known in advance. In the figure the same activation function g is used in all layers.

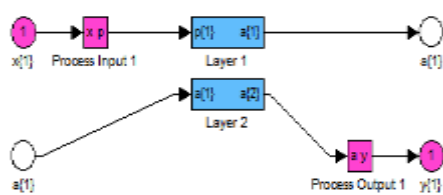

Fig. 6. Simulink structure of artificial neural network controller

V.SIMULATION RESULTS

A. PERFORMANCE OF THE DVR SYSTEM

The performance of the DVR is demonstrated for different supply voltage disturbances such as voltage sag and swell. Fig. 8 shows the transient performance of the system under voltage sag and voltage swell conditions. At 0.2 s, a sag in supply voltage is created for five cycles, and at 0.4 s, a swell in the supply voltages is created for five cycles. It is observed that the load voltage is regulated to constant amplitude under both sag and swell conditions. PCC voltages v_s , load voltages

v_L , DVR voltages v_C , amplitude of load voltage V_L and PCC voltage V_s , source currents i_s , reference load voltages v_{Lref} , and dc bus voltage v_{dc} are also depicted in Fig.7.

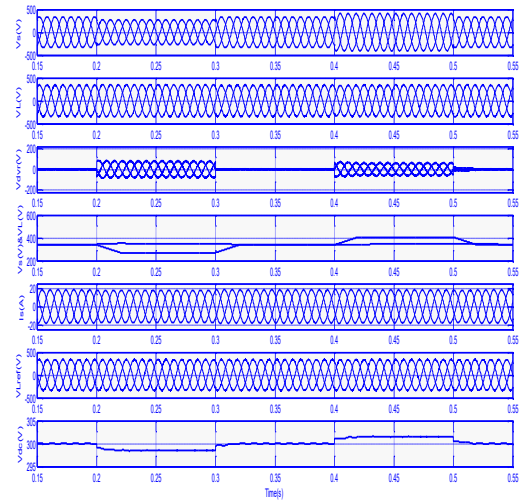

Fig. 7. Dynamic performance of DVR with in-phase injection during voltage sag and swell applied to critical load.

Table1: Comparison of Total Harmonic Distortion with PI and ANN controllers

	PI Controller THD	ANN Controller THD
Source Voltage	6.41%	5.89%
Source Current	1.02%	0.98%
Load Voltage	0.71%	0.57%

VI. CONCLUSION

The operation of a DVR has been demonstrated with an improved control technique using various voltage injection schemes. A comparison of the DVR's performance with different schemes has been performed. An ANN controller based VSC, including in this DVR. The reference load voltage has been predicted using the method of unit vectors, and control of DVR has been achieved, which minimizes voltage injection error. SRF theory is employed for estimating reference DVR voltages. It is concluded that voltage injection in phase with the PCC voltage. This power quality improvement and reduction in the THD in load voltage explain the effectiveness of the DVR based ANN control strategy used in this work.

REFERENCES

- [1] M. H. J. Bollen, *Understanding Power-Quality Problems—Voltage-Sags and Voltage-Interruptions*. New York, NY, USA: IEEE Press, 2000.
- [2] A. Ghosh and G. Ledwich, *Power Quality Enhancement Using Custom Power Devices*. London, U.K.: Kluwer, 2002.
- [3] M. H. J. Bollen and I. Gu, *Signal Processing of Power Quality Disturbances*. Hoboken, NJ, USA: Wiley-IEEE Press, 2006.
- [4] R. C. Dugan, M. F. McGranaghan, and H. W. Beaty, *Electric Power Systems Quality*, 2nd ed. New York, NY, USA: McGraw-Hill, 2006.
- [5] A. Moreno-Munoz, *Power Quality: Mitigation Technologies in a Distributed Environment*. London, U.K.: Springer-Verlag, 2007.
- [6] K. R. Padiyar, *FACTS Controllers in Transmission and Distribution*. New Delhi, India: New Age Int., 2007.
- [7] IEEE Recommended Practices and Recommendations for Harmonics Control in Electric Power Systems, IEEE Std. 519, 1992.
- [8] V. B. Bhavraju and P. N. Enjeti, "An active line conditioner to balance voltages in a three phase system," *IEEE Trans. Ind. Appl.*, vol. 32, no. 2, pp. 287–292, Mar./Apr. 1996.
- [9] S. Middlekauff and E. Collins, "System and customer impact," *IEEE Trans. Power Del.*, vol. 13, no. 1, pp. 278–282, Jan. 1998.
- [10] M. Vilathgamuwa, R. Perera, S. Choi, and K. Tseng, "Control of energy optimized dynamic voltage restorer," *in Proc. IEEE IECON*, 1999, vol. 2, pp. 873–878.
- [11] J. G. Nielsen, F. Blaabjerg, and N. Mohan, "Control strategies for dynamic voltage restorer compensating voltage sags with phase jump," *in Proc. IEEE APEC*, 2001, vol. 2, pp. 1267–1273.
- [12] A. Ghosh and G. Ledwich, "Compensation of distribution system voltage using DVR," *IEEE Trans. Power Del.*, vol. 17, no. 4, pp. 1030–1036, Oct. 2002.
- [13] A. Ghosh and A. Joshi, "A new algorithm for the generation of reference voltages of a DVR using the method of instantaneous symmetrical components," *IEEE Power Eng. Rev.*, vol. 22, no. 1, pp. 63–65, Jan. 2002.