

Integrated Traffic Control System for Emergency Vehicles

Dr.SP.Yadav

spyadav68@gmail.com

ECE Department,

Guru Nanak Institute of Technology,
Hyderabad

Vulle Manasa

vullemanasa2004@gmail.com

ECE Department,

Guru Nanak Institute of Technology,
Hyderabad

Sunkari Harini

harinisunkari05@gmail.com

ECE Department,

Guru Nanak Institute of Technology,
Hyderabad

Orsu Vamshi

vamshiorsu31@gmail.com

ECE Department,

Guru Nanak Institute of Technology,
Hyderabad

Abstract— The efficient movement of ambulances is crucial for timely response and effective emergency management in urban areas. However, congested road networks often impede their progress, leading to potentially life-threatening delays. It presents an innovative solution: an automated traffic system for emergency vehicles utilizing RF (Radio Frequency) modules. By harnessing RF technology, this system enables seamless communication and coordination between ambulances and the road infrastructure. Real-time vehicle identification, intelligent traffic management, and enhanced safety measures are key features of this system. By dynamically managing traffic flow, optimizing signal timings, and granting priority access to ambulances, the system minimizes response times while minimizing disruption to regular traffic. Moreover, the integration of RF modules paves the way for future advancements, including predictive routing and adaptive traffic management.

I. INTRODUCTION

Traffic congestion is an over-growing problem across world as increasing rate of population, automobiles usage which is proportional to it will also increases without any road infrastructure development. Due to this there will be a chance of high accumulation of vehicles at every traffic junction and during rush-hours it results in high congestion compared to normal times. Because of these situations which creates complexities for flow of emergency vehicles in busy hours and it raise to putting person who are having need of emergency vehicle into critical stage. So, to erase this issue a research on different technologies are done and explored in order to monitor emergency vehicle and control traffic flow introducing green corridor technique. As these technologies will have high maintenance and installation complexities etc.

II. LITERATURE SURVEY

Much of the research and work has been done In the field of INTEGRATED TRAFFIC CONTROL SYSTEM FOR EMERGENCY VEHICLES

Z. A. Shaikh, A. G. Umar, M. R. Hossain – An Intelligent Traffic Control System for Emergency

Vehicles (2018) .Proposed an intelligent traffic control system using sensors and real-time data to prioritize emergency vehicles.

A. Prasad, R. K. Jaiswal-Design and Implementation of Emergency Vehicle Priority System(2020). Developed a microcontroller-based emergency vehicle priority system for smart traffic lights.

M. A. Suh, M. H. Kwon, H. C. Choi – Emergency Vehicle Priority in Integrated Traffic Control Systems (2017). Studied integrated traffic control frameworks enabling emergency vehicle prioritization using centralized systems.

R. B. Sharma, V. G. Ramesh – A Smart Traffic Control System for Emergency Vehicle Management (2019) .Presented a smart traffic control solution utilizing IoT and GPS for efficient emergency vehicle routing.

P. T. R. Meena, P. S. A. Kumar – Dynamic Traffic Signal Control for Emergency Vehicle Prioritization (2016). Proposed dynamic traffic signal adjustment using real-time tracking for emergency vehicle movement.

S. K. Singh, A. Gupta – Emergency Vehicle Management using Vehicular Ad Hoc Networks (2021). Explored emergency vehicle coordination using Vehicular Ad Hoc Networks (VANETs) to reduce response time.

As an emergency vehicle approaches, its location is transmitted to a central server, which dynamically adjusts traffic signals to create a green corridor using predefined algorithms. Wireless communication ensures timely updates, while simulation tools are used to evaluate the system’s effectiveness in reducing response delays.

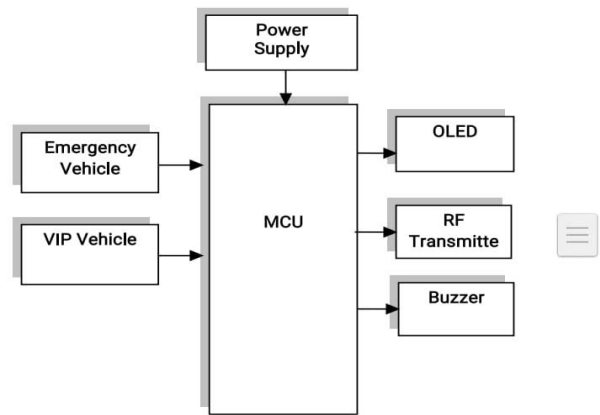

FIG 1 Block Diagram of Transmitter section

III. EXISTING SYSTEM

The existing traffic control system usually operates on fixed traffic signals that don’t prioritize emergency vehicles, causing delays during emergencies.

IV. PROPOSED SYSTEM

The proposed system integrates smart traffic control that automatically detects emergency vehicles and adjusts traffic signals to give them priority, ensuring quicker response times.

V. METHODOLOGY

The system integrates GPS-enabled emergency vehicles, real-time tracking, and intelligent traffic signals to prioritize emergency movement through intersections.

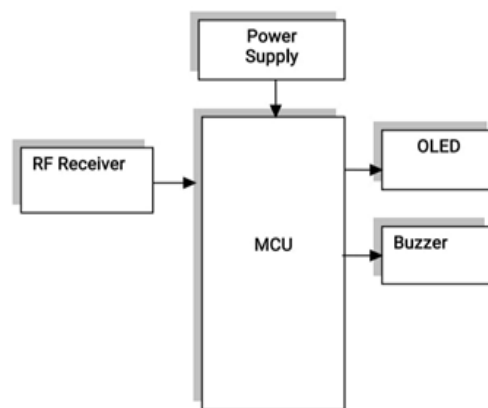

FIG 2 Block Diagram of Receiver section

Applications

Nearly 99 per cent of the processors manufactured end up in embedded systems. The embedded system market is one of the highest growth areas as these systems are used in very market segment- consumer electronics, office automation, industrial automation, biomedical engineering, wireless communication, data communication, telecommunications, transportation, military and so on.

VI. HARDWARE DETAILS

POWER SUPPLY

The power supply section is the section which provide +5V for the components to work. IC LM7805 is used for providing a constant power of +5V.

The ac voltage, typically 220V, is connected to a transformer, which steps down that ac voltage down to the level of the desired dc output. A diode rectifier then provides a full-wave rectified voltage that is initially filtered by a simple capacitor filter to produce a dc voltage. This resulting dc voltage usually has some ripple or ac voltage variation.

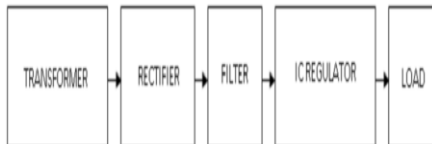

Transformer

Transformers convert AC electricity from one voltage to another with little loss of power. Transformers work only with AC and this is one of the reasons why mains electricity is AC.

Step-up transformers increase voltage, step-down transformers reduce voltage. Most power supplies use a step-down transformer to reduce the dangerously high mains voltage (230V in India) to a safer low voltage.

Voltage Regulators

Voltage regulators comprise a class of widely used ICs. Regulator IC units contain the circuitry for reference source, comparator amplifier, control device, and overload

protection all in a single IC. IC units provide regulation a single IC. IC units provide regulation of either a fixed positive voltage, a fixed negative voltage, or an adjustably set voltage. The regulators can be selected for operation with load currents from hundreds of milli amperes to tens of amperes, corresponding to power ratings from milli watts to tens of watts.

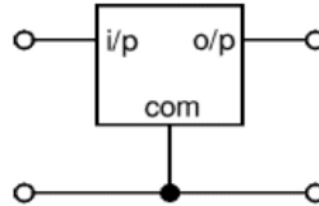

MICROCONTROLLER

The Raspberry Pi foundation changed single-board computing when they released the Raspberry Pi computer, now they're ready to do the same for microcontrollers with the release of the brand-new Raspberry Pi Pico. This low-cost microcontroller board features a powerful new chip, the RP2040, and all the fixin's to get started with embedded electronics projects at a stress-free price.



OLED (Organic Light Emitting Diodes)

OLED (Organic Light Emitting Diodes) is a flat light emitting technology, made by placing a series of organic thin films between two conductors. When electrical current is applied, a bright light is emitted. OLEDs are emissive displays that do not require a backlight and so are thinner and more efficient than LCD displays (which do require a white backlight).

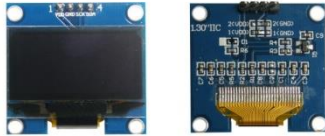

IR SENSOR

IR sensor is very useful if you are trying to make an obstacle avoider robot or a line follower. In this project we are going to make a simple IR sensor which can detect an object around 6-7 cm. IR sensor is nothing but a diode, which is sensitive for infrared radiation. This infrared transmitter and receiver is called as IR TX-RX pair.



RF TRANSMITTER

The function of a radio frequency (RF) transmitter is to modulate, up convert, and amplify signals for transmission into free space. An RF transmitter generally includes a modulator that modulates an input signal and a radio frequency power amplifier that is coupled to the modulator to amplify the modulated input signal.

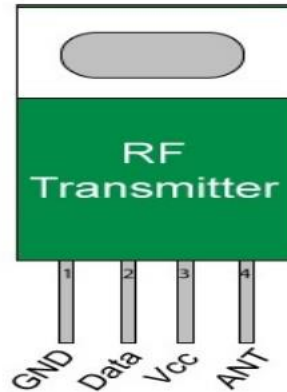

RF RECEIVER

The RF receiver receives an RF signal, converts the RF signal to an IF signal, and then converts the IF signal to a base band signal, which it then provides to the base band processor. As is also known, RF transceivers typically include sensitive components susceptible to noise and interference with one another and with external sources. The RF receiver is coupled to the antenna and includes a low noise amplifier, one or more intermediate frequency stages, a filtering stage, and a data recovery stage.

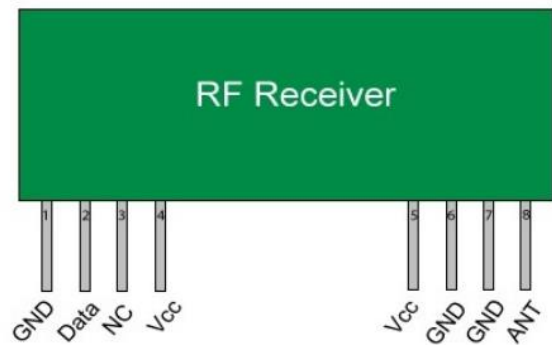

BUZZER

A [buzzer](#) or beeper is a signaling device, usually electronic, typically used in automobiles, household appliances such as a microwave oven, or game shows. It most commonly consists of a number of switches or sensors connected to a control unit that determines if and which button was pushed or a preset time has lapsed, and usually illuminates a light on the appropriate button or control panel, and sounds a warning in the form of a continuous or intermittent buzzing or beeping sound.

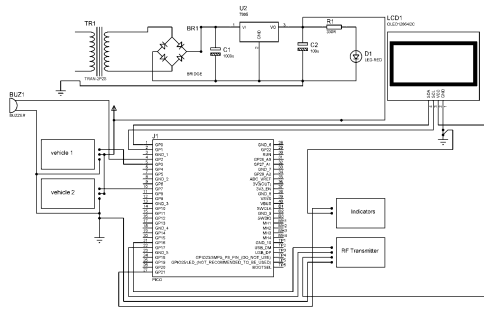

FIG 3 Schematic Diagram of Transmitter Section

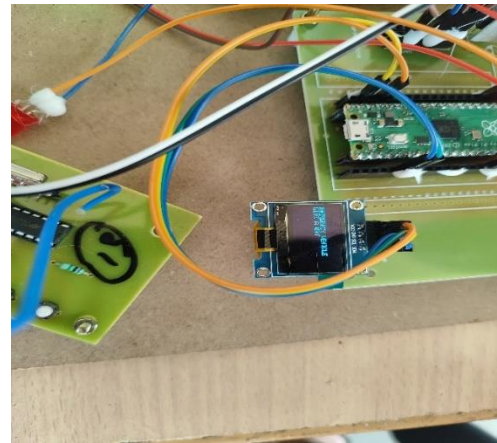

FIG 4 Prototype of The System

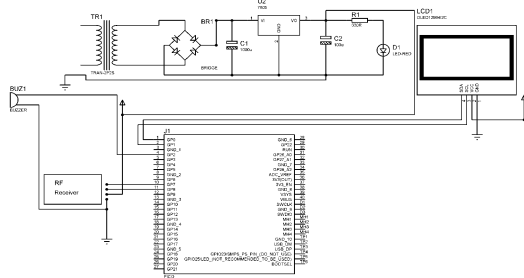

FIG 4 Schematic Diagram of Receiver Section

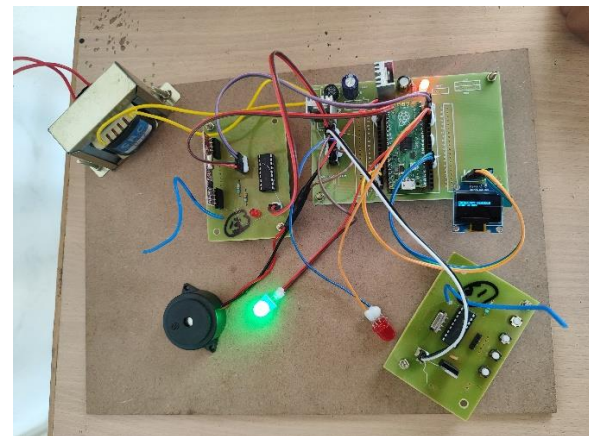

FIG 5 Prototype of The System

VII. SOFTWARE DETAILS

THE ARDUINO INTEGRATED DEVELOPMENT ENVIRONMENT

Arduino Software (IDE) - contains a text editor for writing code, a message area, a text console, a toolbar with buttons for common functions and a series of menus. It connects to the Arduino and Genuino hardware to upload programs and communicate with them.

VIII. CONCLUSION

The paper has the project “Intelligent Traffic Control System for Emergency Vehicle Using RF Technology” has been successfully designed and tested. In this implementation we have used Radio Frequency Technology. It is developed with integration of all hardware components. Existence of every module has been examined out and placed carefully thus contributing to the best working of the unit. Secondly, with the benefit of expanding technology using highly advanced IC's the project has been successfully implemented.

ACKNOWLEDGEMENT

This project stands as a testament to the unwavering support and invaluable contributions of numerous individuals, without whom its fruition would not have been possible. We extend our heartfelt gratitude to the mentors, educators, and technical experts whose guidance and assistance have been instrumental in transforming our vision into reality.

First and foremost, we express our profound appreciation to Dr S P Yadav HOD&DEAN OF ACADEMICS in the Department of Electronics and Communication Engineering, whose unwavering guidance has been pivotal throughout the course of this dissertation.

We are immensely grateful to G.Praveena Reddy, Project Coordinator, and our entire faculty for their ceaseless encouragement and unwavering support, which have served as the driving force behind the completion of this project.

Our sincere thanks extend to Dr. S. P. Yadav, Head of the Department of Electronics and Communication Engineering, whose invaluable suggestions have greatly contributed to the success of this endeavor, serving as a constant source of inspiration.

We also extend our gratitude to Dr.K.Venkata Rao, Principal, for his continuous support and valuable guidance throughout this journey.

We acknowledge with deep appreciation the support and encouragement received from Dr. H.S. Saini, Managing Director of Guru Nanak Group of Institutions, whose unwavering belief in our abilities has been a source of motivation.

Additionally, we express our gratitude to our parents, friends, and all those who have provided encouragement and support along the way. Their belief in us has been a driving force behind our efforts.

Lastly, we extend our thanks to all other staff members, both teaching and non-teaching, for their timely assistance and contributions, which have facilitated the progress of this project.

REFERENCES

- [1] Y. Zhang and Q. Huang , Dynamic Balancing of Distributed Traffic Information System, IEEE International Conference on Consumer Communications and Networking (2007).
- [2] Bilal, J. M., & Jacob, D. (2007). Intelligent Traffic Controller System. IEEE International Conference on Signal Processing and Communications. doi:10.1109/icspc.2007.4728364.
- [3] Varapasad.G, Wahidabanu R.S.D.,“FlexibleRouting Algorithm for Vehicular Area Networks”, in Proc. IEEE Conference on Intelligent Transport Systems Telecommunications, Japan, pp.30-38, 2010.
- [4] Chirag Tahilyani, Niketa Chellani(2013) Traffic Congestion Detection and Control using RFID Technology International Journal of Engineering Research & Technology (IJERT) Vol. 2 Issue 10, October – 2013, ISSN: 2278-0181.
- [5] C Vilarinho, J P Tavares and J.F. Rossetti, Design of a Multiagent System for Real Time Traffic Control, in IEEE journal of Intelligent Systems, Volume: 31, Issue: 4, Pages 68-80, 2016.
- [6] Ramaprasad, S. S., & Sunil Kumar, K. N. (2017). Intelligent traffic control system using GSM technology. 2017 IEEE on Power, Control, Conference Signals and Instrumentation Engineering (ICPCSI).
- [7] Javaid, S., Sufian, A., Pervaiz, S., & Tanveer, M. (2018). "Smart traffic management system using Internet of Things". 20th International Conference on Advanced Communication Technology (ICACT).2018
- [8] R. Puviarasi, Mritha Ramalingam, Elanchezhian Chinnavan," Design of Intelligent Traffic Controlling System using RF Transponder", 4th International Conference on Advances in Electrical, Electronics,

Information, Communication and Bio-Informatics (AEEICB-18).

[9] A Smart Ambulance System D. Sandeep reddy , vandhana khare, pg Scholar, Dept of ECE, CMRCET, Hyderabad, TS, India. 2Associate Professor, Dept of ECE, CMRCET, TS, India.

[10] "Adaptive Traffic Light Control System"., Swapnil Manohar Shinde Student, Dept. of Electronics and Telecommunication Engineering, SRES Sanjivani College of Engineering, Maharashtra, India.

[11] Advanced traffic clearance system for ambulance clearance using rf-434 module” r. surshkumar, r. balaji, g. manikandan and appanaboina masthan Department of Electronics and Communication Engineering, Aarupadai Veedu Institute of Technology, Vinayaka Missions University, CHENNAI (T.N.) INDIA.