

IOT-Based Automatic Smart Street Light

Rugved Jadhav, Avantika Aswale, Nupur Nakhwa, Arya Joshi

Electronics and Telecommunication, Vidyalankar Polytechnic
Electronics and Telecommunication, Vidyalankar Polytechnic
Electronics and Telecommunication, Vidyalankar Polytechnic
Electronics and Telecommunication, Vidyalankar Polytechnic

Abstract - It is a smart street lighting system implemented using IoT technology based on ESP32 that automatically controls and monitors the operations of streetlights in real time. The LDR and PIR sensors will regulate the switching on/off of the street lights depending on whether it is night time or not and in case there is movement. Other sensors such as the current sensors for fault detection, MPU6050 sensors for pole safety, and the MQ135 sensor for air quality monitoring have also been incorporated into the system.

Energy harvesting will also be employed together with IoT technology by connecting the street light poles to WiFi.

Key Words: Internet of Things (IoT), Smart Street Lighting, Energy Efficiency, Energy Harvesting, Sensor-Based Automation

1. INTRODUCTION

Street lights in contemporary cities require considerable energy and operational cost, as well as less effective management by humans. Therefore, IoT Smart Street Lights using ESP32 can resolve such problems by implementing automation and resource optimization within the design.

LDR sensor and motion detection sensors are used in order to turn the street light on and off depending on particular environmental requirements. Other functions that the device implements include fault detection, monitoring air quality, as well as detecting pole safety. Built-in Wi-Fi allows for sending data to a cloud server, such as Blynk or ThingSpeak, in real time.

2. Body of Paper

2.1 System Architecture:

The proposed IoT-based smart street lighting system is designed using a centralized control architecture with the ESP32 microcontroller as the main processing unit. Various sensors such as LDR, IR, MQ135, and MPU6050 are connected to the ESP32 to collect real-time environmental data. The LDR sensor detects light intensity, the IR sensor detects motion, the MQ135 monitors air quality, and the MPU6050 detects vibration or tilt of the pole.

The ESP32 processes all sensor inputs and controls the street light through a relay module. A buck converter is used to provide a stable power supply to the system. The ESP32 also uses its built-in Wi-Fi to send data to IoT cloud platforms like Blynk for remote monitoring and control. This architecture ensures automatic operation, real-time monitoring, improved safety, and energy-efficient street lighting suitable for smart city applications.

2.2 Working Principle:

The smart street lighting system comprises of ESP32 which controls the street lights according to the feedback obtained from the sensors. The LDR light sensor detects the presence of darkness and daylight, which enables it to switch the lights off during the daytime and on at nighttime through the use of relay module. IR motion sensor detects the motion and boosts the illumination whenever there are people or vehicles around.

There are other sensors such as MQ135 and MPU6050 that are utilized in monitoring air quality and detecting vibrations or tilting. All the data collected is analyzed by the ESP32 and can be transferred to an Internet of Things system using Wi-Fi technology.

2.3 Components Used:

ESP32 Microcontroller
IR Sensor
LED Lights
Relay Module
MPU6050
LDR Sensor
MQ135
Buck Converter

Table -1:

Components & Their Functions

Component	Function
ESP32	Controls the system and enables IoT communication
IR Sensor	Detects motion or nearby objects
LED Lights	Provides energy-efficient illumination
Relay Module	Controls switching of lights (ON/OFF)
MPU6050	Detects motion, tilt, or vibration (accidents)
LDR Sensor	Detects ambient light intensity
MQ135 Sensor	Detects air quality and harmful gases
Buck Converter	Regulates and steps down voltage supply

Sensor Specifications

Sensor	Parameter	Range	Output
IR Sensor	Obstacle/Motion Detection	2 – 30 cm (approx.)	Digital
MPU6050	Acceleration & Gyroscope	+2g to +16g	Digital (I2C)
LDR	Light Intensity	0 – 1000 lux (approx.)	Analog
MQ135	Gas/Air Quality	10 – 1000 ppm	Analog

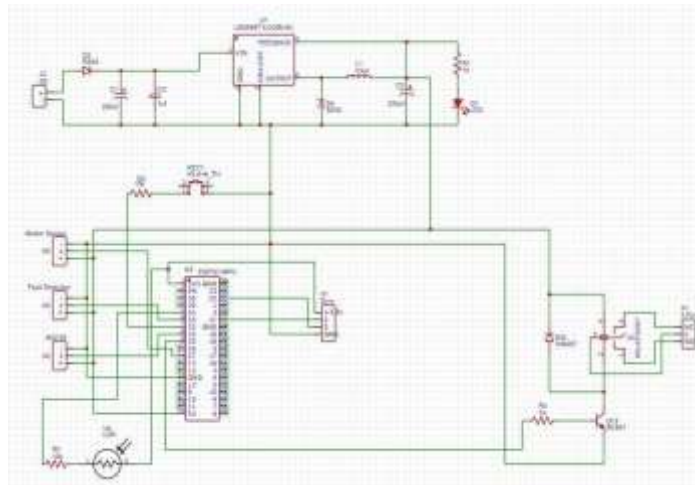

Fig -1: IoT-Based Automatic Smart Street Light

3. CONCLUSIONS

The smart street light system based on ESP32 is efficient, automated, and intelligent. It is designed to control the street lights based on the environmental conditions and the movement of the people or the vehicles using the sensors like LDR and motion sensors. This will help in reducing the wastage of power.

Some additional sensors like gas sensors, vibration sensors, and current sensors have been added to the system. These sensors will help in monitoring the environmental conditions and detecting the problems that may have occurred in the street light circuit.

Using the IoT technology, the system can be monitored and controlled through the wireless network. This will help the authorities to access the data from the system at any time and will be aware of the problems that have occurred in the system.

Thus, the proposed system is efficient in reducing the wastage of power and is very helpful in the development of the smart city.

REFERENCES

1. Automated Street Lighting System Using IoT – Amira Nasir Farhan
https://www.researchgate.net/publication/393638162_Automated_Street_Lighting_System_Using_IOT
2. A Comprehensive Survey on IoT-Based Smart Public Street Lighting – S. Khemakhem
<https://www.sciencedirect.com/science/article/pii/S2773186324000720>
3. IoT Based Smart Street Light System – T. Gopinath
https://www.researchgate.net/publication/380951400_IOT_BASED_SMART_STREET_LIGHT_SYSTEM
4. A Study on IoT Based Smart Street Light Systems
<https://www.ijert.org/a-study-on-iot-based-smart-street-light-systems>
5. Smart Street Lighting Using IoT
https://www.researchgate.net/publication/390660540_SMART_STREET_LIGHTING_USING_IOT