

IoT based Noise and Air pollution Monitoring System

Khimanshu Balbudhe, Pratik Tayde, Prajwal Gajbhiye, Soyel Sheikh, Mr. D. G. Gahane

Department of Electronics & Telecommunication Engineering

Priyadarshini College of Engineering, Nagpur

Abstract— This project develops an IoT-based system to continuously monitor noise and air pollution in urban, industrial, and residential areas in a cost-effective and reliable way. The system utilizes an ESP32 microcontroller integrated with a sound sensor and MQ135 gas sensor to measure ambient noise levels and air quality parameters in real time. The collected data is processed and compared with predefined safety thresholds, displayed locally on an LCD, and transmitted to a cloud-based dashboard via Wi-Fi for remote monitoring. An alert mechanism using a buzzer is activated whenever pollution levels exceed safe limits, ensuring immediate awareness and timely response. Owing to its low cost, scalability, real-time monitoring capability, and remote accessibility, the proposed system supports smart city initiatives, environmental protection, and public health management.

Keywords: *IoT, Noise Pollution, Air Pollution, ESP32, MQ135 Gas Sensor, Sound Sensor, Real-Time Monitoring, Smart Cities*

I. INTRODUCTION

Noise and air pollution have become serious environmental concerns in recent years due to rapid urbanization, industrial expansion, and the continuous growth of transportation systems. Increasing population density and human activities such as traffic congestion, construction work, and industrial operations have significantly degraded air quality and raised ambient noise levels. These environmental issues are often overlooked because their effects are not always immediately

visible, yet they pose long-term risks to human health, ecological balance, and overall quality of life.

Air pollution consists of harmful gases and particulate matter released into the atmosphere from vehicles, industries, and burning of fossil fuels. Pollutants such as carbon dioxide, nitrogen oxides, ammonia, and smoke contribute to respiratory diseases, cardiovascular problems, and environmental degradation. Similarly, noise pollution caused by excessive sound levels from traffic, machinery, and public activities leads to hearing loss, stress, sleep disorders, and reduced productivity. Continuous exposure to such conditions emphasizes the need for efficient monitoring systems that can detect pollution levels accurately and promptly.

Traditional noise and air pollution monitoring systems are usually expensive, bulky, and limited to fixed locations. These systems often require manual data collection and do not provide real-time information, making them unsuitable for continuous and widespread monitoring. As a result, pollution spikes may go unnoticed, delaying preventive measures and increasing health risks. This limitation creates a demand for a more flexible, automated, and cost-effective solution that can provide real-time environmental data.

The advancement of the Internet of Things (IoT) has enabled the development of smart monitoring systems using interconnected sensors, microcontrollers, and cloud platforms. IoT-based systems allow continuous data collection, real-time processing, and remote accessibility of information. By integrating sensors with wireless

communication, IoT offers a scalable and efficient approach to environmental monitoring that can be deployed across multiple locations.

In this context, the proposed IoT-based Noise and Air Pollution Monitoring System aims to provide real-time monitoring, instant alerts, and remote data access using an ESP32 microcontroller, sound sensor, and MQ135 gas sensor. The system supports smart city development, enhances public awareness, and assists authorities in making informed decisions for environmental protection and sustainable urban planning.

II. AIMS & OBJECTIVES

Aim

The primary aim of the proposed system is to design and develop an efficient, intelligent, and automated solution that enhances system performance, reliability, and sustainability by integrating embedded hardware, sensors, and software platforms. The system focuses on real-time monitoring, control, and optimization to overcome the limitations of conventional manual or fixed systems, thereby improving overall operational efficiency and reducing human intervention.

Objectives

1. To design and implement a robust embedded system architecture using a suitable microcontroller platform for real-time data acquisition and control.
2. To continuously monitor critical system parameters using appropriate sensors and ensure accurate data collection under varying environmental conditions.
3. To process sensor data efficiently and make intelligent decisions through programmed control logic or algorithms.
4. To automate system operations in order to minimize manual intervention, reduce human error, and improve consistency in performance.
5. To display real-time system status, measured parameters, and operational feedback using a user-

friendly interface such as an LCD, OLED, or web-based dashboard.

6. To ensure energy-efficient operation by optimizing power consumption and utilizing renewable or low-power components wherever applicable.
7. To validate the system performance through experimental testing and analyze results to demonstrate improvements over traditional methods in terms of efficiency, accuracy, and reliability.

These aims and objectives collectively guide the development of the proposed system, ensuring it meets technical requirements while addressing practical challenges and future scalability.

III. LITERATURE SURVEY

The study of environmental monitoring systems has gained significant attention due to the increasing levels of air and noise pollution in urban and industrial regions. Traditional monitoring stations have been widely used to measure air quality and noise levels; however, these systems are often expensive, stationary, and limited in number, which restricts their ability to provide real-time and location-specific data. As a result, researchers have shifted their focus toward low-cost, scalable, and real-time monitoring solutions using IoT-based technologies that can be deployed in multiple locations for continuous environmental assessment.

Several research works highlight the use of gas sensors such as MQ135 and MQ7 for detecting harmful gases like carbon monoxide, carbon dioxide, ammonia, and smoke. These sensors are widely preferred due to their low cost, ease of integration, and ability to detect multiple pollutants. In many IoT-based air quality monitoring systems, MQ series sensors are interfaced with microcontrollers such as ESP32 or ESP8266 to collect and process real-time environmental data. These systems typically display air quality information on LCD screens and transmit data to cloud platforms for remote monitoring and analysis, enabling users to access pollution levels through web or mobile applications.

In addition to air quality monitoring, noise pollution measurement has also been integrated into smart environmental systems using sound sensors or microphones. These sensors convert sound intensity into electrical signals, which are then processed by microcontrollers to determine noise levels in decibels or relative units. Literature indicates that combining air and noise monitoring into a single system provides a more comprehensive understanding of environmental conditions, especially in urban areas where both forms of pollution occur simultaneously due to traffic congestion, construction activities, and industrial operations.

The role of IoT in environmental monitoring has been widely emphasized in recent studies. IoT-enabled systems allow real-time data acquisition, wireless transmission, and cloud-based storage of environmental parameters. Using Wi-Fi modules integrated into microcontrollers like ESP32, sensor data can be continuously uploaded to cloud dashboards where it is visualized in graphical formats. This enables remote accessibility, long-term data storage, and trend analysis, which are essential for smart city development and environmental management strategies. Research also shows that IoT-based systems improve responsiveness by enabling real-time alerts when pollution levels exceed safe thresholds.

Further advancements in literature suggest the integration of distributed and mobile sensor networks to improve spatial coverage of pollution monitoring. Instead of relying on fixed monitoring stations, some systems propose deploying sensor nodes across different locations or even on moving platforms such as public transport vehicles. This approach increases the density of collected data and provides a more accurate representation of environmental conditions across a wider area. Cloud-based architectures combined with IoT sensors also enable scalable and flexible systems that can be expanded easily based on monitoring requirements.

Another important aspect discussed in the literature is the use of real-time alert systems. Many IoT-based pollution monitoring systems incorporate buzzer alarms, LEDs, or mobile notifications to alert users when pollution levels exceed predefined safety limits. This feature is crucial for

immediate response and helps reduce prolonged exposure to harmful environmental conditions. Studies emphasize that combining monitoring, visualization, and alert mechanisms significantly improves the effectiveness of environmental safety systems.

Recent research trends also focus on enhancing data analytics and prediction capabilities using IoT-generated environmental data. By storing long-term pollution data in cloud platforms, researchers can analyze trends, identify pollution hotspots, and even predict future pollution levels using machine learning techniques. This helps in better urban planning, traffic management, and industrial regulation. Such intelligent systems contribute to the development of smart cities by enabling data-driven decision-making and proactive environmental control.

Overall, the literature clearly indicates a transition from conventional static monitoring systems to smart IoT-based environmental monitoring solutions. These systems are characterized by low cost, real-time operation, wireless communication, and cloud integration. The proposed IoT-based Noise and Air Pollution Monitoring System aligns with these advancements by combining MQ135 gas sensing, sound level detection, ESP32-based processing, cloud connectivity, and alert mechanisms to provide an efficient and scalable solution for modern environmental challenges.

IV. METHODOLOGY

The methodology of this IoT-based Noise and Air Pollution Monitoring System explains the step-by-step process used to design and develop a real-time monitoring system. It focuses on integrating hardware components such as sensors and microcontroller units with software platforms like cloud services and embedded programming tools. The main goal of this methodology is to ensure accurate data acquisition, efficient processing, real-time visualization, and timely alert generation for effective monitoring of environmental conditions.

1. System Design and Component Integration

The first step in the methodology involves selecting and integrating appropriate hardware components. The system consists of an ESP32 microcontroller as the central processing unit, a sound sensor for measuring noise levels, and an MQ135 gas sensor for detecting air pollutants. These sensors are interfaced with the ESP32 through analog input pins. Additional components such as an LCD display, buzzer, voltage regulator, and power supply are included to support output display, alert generation, and stable operation. Proper circuit design ensures reliable communication between all components.

2. Sensor Data Acquisition

In this stage, the sound sensor continuously captures ambient noise levels from the surrounding environment, while the MQ135 gas sensor detects harmful gases such as CO₂, NH₃, NO_x, smoke, and other pollutants. These sensors generate analog signals proportional to the intensity of noise and concentration of gases. The signals are then sent to the ESP32 microcontroller for further processing. This step ensures continuous environmental data collection in real time.

3. Signal Conversion and Data Processing

The ESP32 reads the analog signals and converts them into digital values using its built-in ADC. These digital readings are then calibrated and mapped into meaningful values representing noise levels and air quality indicators. The system applies predefined threshold values to determine whether the environmental conditions are safe or unsafe. This processing stage ensures accurate interpretation of raw sensor data.

4. Decision Making and Control Logic

After processing the sensor data, the system compares the measured values with predefined safety limits. If both noise and air pollution levels are within acceptable ranges, the system continues normal operation. However, if any parameter exceeds the threshold, the ESP32 triggers an alert condition. This decision-making process is a key part of the

methodology as it determines system responses such as display updates and alarm activation.

5. Local Display and Alert Mechanism

The processed data is displayed on a 16×2 LCD screen to provide real-time environmental readings at the monitoring location. In addition, if pollution levels exceed safe limits, the buzzer is activated to generate an audible alert. This dual-output system ensures that users are immediately informed about environmental conditions both visually and audibly, improving safety and awareness.

6. IoT Communication and Cloud Integration

The ESP32 uses its built-in Wi-Fi module to transmit real-time sensor data to a cloud platform. This enables remote monitoring of noise and air pollution levels through a web or mobile dashboard. The cloud system stores both real-time and historical data, allowing users to analyze trends, identify pollution hotspots, and make informed decisions. This step ensures scalability and remote accessibility of the system.

Working of the System

1. The system is powered ON, and the ESP32 initializes all connected sensors and modules.
2. The sound sensor measures ambient noise levels continuously, while the MQ135 sensor detects air quality parameters.
3. The analog signals from both sensors are sent to the ESP32, where they are converted into digital values using ADC.
4. The ESP32 processes the data and compares it with predefined threshold values for safe environmental conditions.
5. Real-time noise and air quality readings are displayed on the LCD screen for local monitoring.
6. If pollution levels exceed safe limits, the buzzer is activated to generate an alert.
7. Simultaneously, the ESP32 sends the processed data to a cloud platform using Wi-Fi for remote monitoring.

8. The system continuously repeats this cycle, ensuring uninterrupted real-time monitoring of environmental conditions.

The methodology clearly explains the structured approach used in designing and implementing the system, while the working demonstrates how each component interacts in real time. Together, they ensure that the IoT-based Noise and Air Pollution Monitoring System provides accurate, efficient, and continuous environmental monitoring suitable for smart cities and public safety applications.

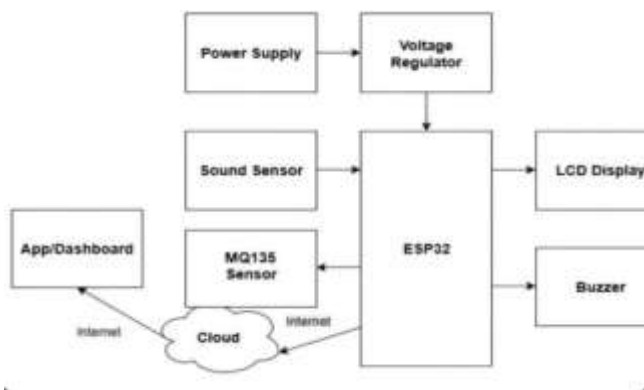

Figure 1: Block Diagram

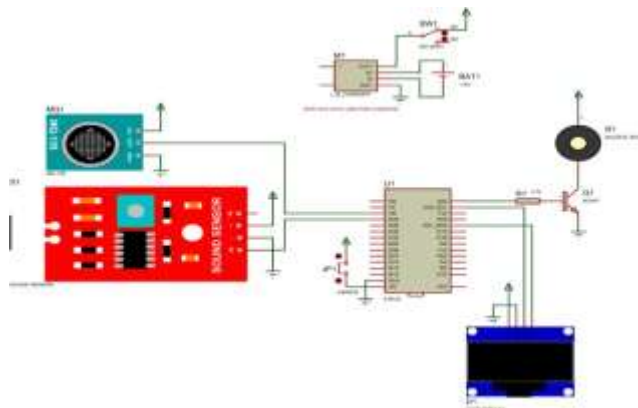

Figure 2: Circuit Diagram

V. RESULTS & CONCLUSION

Results

The implementation of the IoT-based Noise and Air Pollution Monitoring System showed effective and reliable performance in monitoring environmental conditions in real time. The system successfully measured ambient noise levels using the sound sensor and detected air quality variations using the MQ135 gas sensor. The ESP32 processed the sensor

data accurately and displayed real-time readings on the LCD screen with minimal delay. Additionally, the system efficiently transmitted data to the cloud platform, enabling remote monitoring and visualization of pollution levels through a dashboard. The buzzer alert mechanism also functioned properly, activating immediately whenever noise or air pollution exceeded predefined threshold values. Overall, the system demonstrated stable operation, accurate sensing, and continuous monitoring capability, making it suitable for real-world environmental applications.

Conclusion

The IoT-based Noise and Air Pollution Monitoring System provides an efficient, low-cost, and scalable solution for continuous environmental monitoring. By integrating sensors, ESP32 microcontroller, cloud connectivity, and alert mechanisms, the system successfully addresses the limitations of traditional pollution monitoring methods. It enables real-time data acquisition, local display, remote access, and instant alerts, thereby improving awareness and response to hazardous environmental conditions. The system proves to be highly useful for smart cities, industrial zones, and residential areas, contributing to better environmental management and public health protection. With further enhancements such as advanced sensors and predictive analytics, the system can be further improved for more accurate and intelligent pollution monitoring.

REFERENCES

1. Mishra, Ayaskanta. "Air pollution monitoring system based on IoT: Forecasting and predictive modeling using machine learning." In the International Conference on Applied Electromagnetics, Signal Processing and Communication (AESPC). 2018.
2. Jo, ByungWan, and Rana Muhammad Asad Khan. "An internet of things system for underground mine air quality pollutant prediction based on azure machine learning." *Sensors* 18, no. 4 (2018): 930.
3. Ayele, TemeseganWalelign, and Rutvik Mehta. "Air pollution monitoring and prediction using IoT." In 2018

- second international conference on inventive communication and computational technologies (ICICCT), pp. 1741-1745. IEEE, 2018.
4. Pushpam, VS Esther, and N. S. Kavitha. "IoT enabled machine learning for vehicular air pollution monitoring." In 2019 International Conference on Computer Communication and Informatics (ICCCI), pp. 1-7. IEEE, 2019.
 5. Pushpam, VS Esther, and N. S. Kavitha. "IoT enabled machine learning for vehicular air pollution monitoring." In 2019 International Conference on Computer Communication and Informatics (ICCCI), pp. 1-7. IEEE, 2019.
 6. Srivastava, Chavi, Shyamli Singh, and Amit Prakash Singh. "IoT-enabled air monitoring system." In Intelligent Systems, Technologies and Applications: Proceedings of ISTA 2018, pp. 173-180. Singapore: Springer Singapore, 2019.
 7. Srivastava, Harshit, Shashidhar Mishra, Santos Kumar Das, and Santanu Sarkar. "An IoT-Based Pollution Monitoring System Using Data Analytics Approach." In Electronic Systems and Intelligent Computing: Proceedings of ESIC 2020, pp. 187-198. Springer Singapore, 2020.
 8. Shetty, Chetan, B. J. Sowmya, S. Seema, and K. G. Srinivasa. "Air pollution control model using machine learning and IoT techniques." In Advances in Computers, vol. 117, no. 1, pp. 187-218. Elsevier, 2020.
 9. Zhibin Liu, Guangwen Wang, Liang Zhao, Guangfei Yang, "Multi-Points Indoor Air Quality Monitoring Based on Internet of Things", IEEE Access- March 26, (2021).
 10. Rafael Fayos-Jordan, Jaume Segura-Garcia, Antonio Soriano-Asensi, Santiago Felici-Castell, Jose M. Felisi, Jose M. Alcaraz-Calero, "VentQsys: Low-cost open IoT system for CO2 monitoring in classrooms", Wireless Networks (2021)27:5313– 5327, [https://doi.org/10.1007/s11276-021-02799-5\(0123456789-vol V\) \(2021\)](https://doi.org/10.1007/s11276-021-02799-5(0123456789-vol V) (2021)).
 11. T. Manglani et al., "IoT-based Air and Sound Pollution Monitoring System for Smart Environment," 2022 International Conference on Electronics and Renewable Systems (ICEARS), 2022, pp. 604-607.
 12. Chourey, P., Soni, K., Singh, N.J. and Agarwal, R., 2022. IoT-Sodar Network for Airshed Management Planning. IETE Journal of Research, pp.1-15.
 13. J. J. Saldaña-Barrios, M. A. Cedeño-Cedeño, and R. Rodríguez-Vázquez, "Designing an IoT-Based System for Monitoring Noise in Urban Environments," Sensors, vol. 23, no. 22, pp. 1–18, Nov. 2023, doi: 10.3390/s23229015.