

IOT-Enabled Aquaculture Management System

Prof. Dr. R Senthil Kumar, Abhinav Sajeevan, Abhirami K V, Adhithya E V, Elizabeth T Mani

EEE Department, Vimal Jyothi Engineering College, Kannur, India EEE Department,

Vimal Jyothi Engineering College, Kannur, India

Abstract – Aquaculture plays a significant role in satisfying the growing global demand for seafood products. However, maintaining optimal water quality and ensuring the health of aquatic organisms remain major challenges for fish farmers. Factors such as temperature fluctuations, dissolved oxygen levels, pH imbalance, and water contamination can significantly affect fish growth and lead to economic losses if not monitored properly.

Traditionally, aquaculture management relies on manual monitoring and periodic testing of water quality parameters. These methods are time-consuming, less accurate, and often fail to provide real-time insights, making it difficult to respond quickly to unfavorable conditions. As a result, there is a need for an automated, efficient, and reliable system to manage aquaculture environments.

To address these issues, this project proposes an IoT Enabled Aquaculture Management System that provides continuous monitoring and intelligent control of water quality parameters. The system utilizes various sensors to measure key factors such as temperature, pH, turbidity, and dissolved oxygen in real time. The collected data is processed using a microcontroller and transmitted to a cloud platform through IoT technology.

Based on the sensor data, the system can automatically control devices such as aerators, water pumps, and feeding mechanisms to maintain optimal conditions for aquatic life. In addition, farmers can monitor real-time data and receive alerts through a mobile application, enabling remote supervision and timely intervention when abnormal conditions are detected.

Overall, the proposed system improves efficiency, reduces manual effort, enables real-time monitoring, and enhances productivity in aquaculture operations. By integrating IoT technology with smart automation, the proposed solution aims to ensure sustainable fish farming and maximize yield while minimizing resource wastage.

Key Words: IoT, Aquaculture, Water Quality Monitoring, ESP32, Smart Fish Feeder, Firebase, Automation

1.INTRODUCTION

Aquaculture has emerged as one of the fastest-growing sectors in food production, playing a critical role in meeting the increasing global demand for fish and other aquatic products. In countries like India, aquaculture serves as a major source of livelihood for rural communities, contributing significantly to food security, employment generation, and economic development. With the steady rise in population and declining capture fisheries, the importance of efficient and sustainable aquaculture practices has become more prominent than ever.

Despite its rapid growth, aquaculture faces several challenges, particularly in maintaining optimal water quality and ensuring the healthy growth of aquatic organisms. Key parameters such as temperature, pH, dissolved oxygen, turbidity, and ammonia levels directly influence fish metabolism, growth rate, and survival. Even slight variations in these parameters can lead to stress, disease outbreaks, and large-scale mortality, resulting in significant financial losses for farmers. In traditional aquaculture systems, monitoring of these parameters is performed manually, which is time-consuming, labor-intensive, and often lacks accuracy and real-time responsiveness.

Conventional methods also fail to provide continuous monitoring and timely alerts, making it difficult for farmers to take immediate corrective actions. Delayed responses to unfavorable water conditions can severely impact productivity and resource utilization. Furthermore, manual feeding practices often result in overfeeding or underfeeding, leading to feed wastage and water pollution.

Recent developments in IoT, sensor technology, and automation have enabled the development of intelligent aquaculture management solutions. IoT technology allows continuous data collection, remote supervision, and automated control of aquaculture environments. The integration of sensors, microcontrollers, and cloud

platforms allows continuous monitoring of water quality parameters and optimize farm operations with minimal human intervention.

In this work, an IoT-enabled aquaculture management system is proposed to provide continuous monitoring and intelligent control of critical water parameters. The system utilizes multiple sensors to measure temperature, pH, turbidity, and dissolved oxygen, with data transmitted to a cloud-based platform for analysis and visualization. Based on predefined threshold values, automated control mechanisms regulate aerators, water pumps, and feeding systems to maintain optimal conditions. Additionally, a mobile application interface allows farmers to monitor real-time data and receive instant alerts in case of abnormal conditions.

By combining IoT technology with smart automation, the proposed system aims to improve operational efficiency, reduce manual effort, enhance productivity, and promote sustainable aquaculture practices.

2. LITERATURE REVIEW

With the advancement of the Internet of Things (IoT), wireless sensor networks, and smart automation technologies, aquaculture management systems have evolved significantly in recent years. Researchers have focused on developing intelligent systems capable of monitoring water quality parameters in real time and automating farm operations to improve productivity and sustainability.

Several studies have emphasized IoT-based water quality monitoring systems. For instance, Kumar et al. (2022) [1] proposed an IoT-enabled framework that uses sensors to monitor parameters such as temperature, pH, and turbidity, with data transmitted to a cloud platform for visualization. Their system provides real-time monitoring; however, it lacks automated control mechanisms to respond to changing environmental conditions.

Automation in aquaculture has also been explored to reduce manual intervention. Zhang et al. (2021) [2] developed an automated aquaculture system integrating dissolved oxygen sensors with aeration control. The system activates aerators when oxygen levels fall below a threshold, improving fish survival rates. While effective, the system is limited to a single parameter and does not consider multiple environmental factors simultaneously.

Cloud-based solutions have further improved remote accessibility and data analysis. Patel et al. (2023) [4] introduced a cloud-integrated aquaculture monitoring system that allows farmers to access real-time data through mobile applications. The system also provides

alert notifications for abnormal conditions. However, it primarily focuses on monitoring and lacks intelligent decision-making for automated control.

Recent research has also explored the integration of machine learning techniques for predictive analysis. Singh et al. (2024) [5] proposed a smart aquaculture system that uses machine learning algorithms to predict water quality trends and optimize feeding schedules. Although this approach enhances efficiency, it requires high computational resources and large datasets for training.

In addition, energy-efficient system design has been a key research focus. Rahman et al. (2022) [6] developed a low-power IoT-based monitoring system using optimized sensor sampling and sleep modes to extend battery life in remote aquaculture farms. Their work highlights the importance of sustainable and cost-effective system deployment.

In this work, an integrated IoT-enabled aquaculture management system is proposed that combines real-time multi-parameter monitoring, automated control of aeration and feeding mechanisms, cloud-based data management, and mobile application support. The proposed system aims to overcome the limitations of existing solutions by providing a comprehensive, scalable, and efficient approach to modern aquaculture management.

3. PROPOSED SYSTEM AND METHODOLOGY

The proposed IoT-Enabled Aquaculture Management System operates through a structured process that integrates real-time sensing, automated control, and cloud-based communication. The methodology begins with continuous monitoring of pond water parameters using pH, turbidity, and temperature sensors interfaced with the ESP32 microcontroller. These sensors collect environmental data at regular intervals and transmit it to the controller for processing. The microcontroller compares the measured values with predefined threshold limits to determine whether corrective actions are required.

When turbidity levels exceed the acceptable range, the system automatically activates the outlet pump through a relay module to remove contaminated water. After draining a specified amount, the inlet pump is triggered to refill the pond with fresh water, thereby restoring water clarity and maintaining optimal conditions for fish growth. Temperature and pH values are continuously logged and displayed both locally on a 16×2 LCD display and remotely through a mobile application.

For automated feeding, the system uses a Real-Time Clock (RTC)-based scheduling mechanism integrated within the ESP32. At predefined feeding times set via the mobile application, the controller sends step pulses to the A4988 motor driver, which drives a NEMA 17 stepper motor connected to a 3D-printed auger mechanism. This ensures controlled and precise dispensing of fish feed, minimizing wastage and improving feed efficiency.

All sensor data and system statuses are transmitted via Wi-Fi to the Firebase Realtime Database, enabling real-time cloud storage and synchronization. The Android application developed using Kodular retrieves this data for remote monitoring and allows users to configure feeding schedules and system parameters. Additionally, an ESP32-CAM module provides live surveillance of the pond environment. Through this integrated methodology, the system achieves automation, remote accessibility, improved water management, and enhanced overall productivity in aquaculture operations.

4. SYSTEM ARCHITECTURE

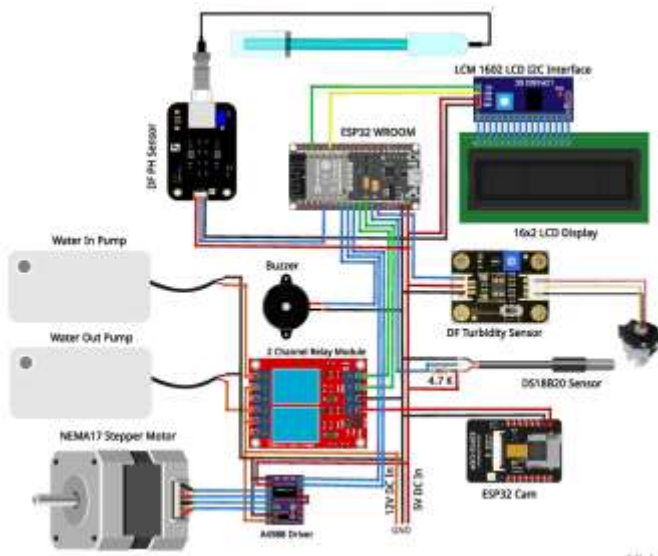

Fig.1. Design of IoT-based Smart Fish Feeder Device

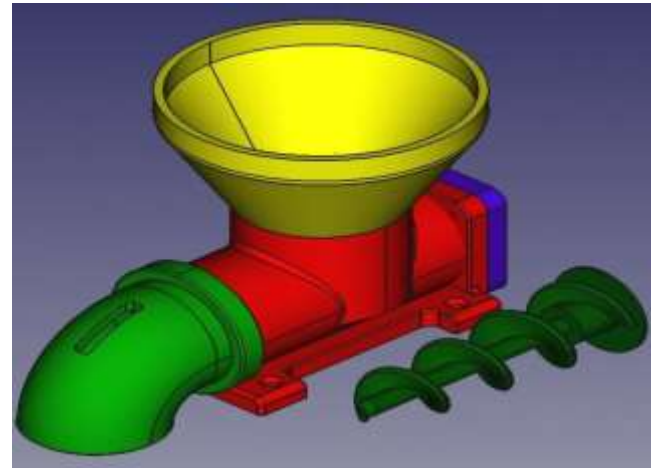

Fig.2. 3D-Printed Feeder Mechanism



Fig.3. App Screenshot -Dashboard And Feeder Settings

The system architecture of the proposed IoT-Enabled Aquaculture Management System is designed as an integrated framework consisting of sensing, processing, control, and communication layers. At the core of the architecture is the ESP32 microcontroller, which acts as the central control unit. The sensing layer includes pH, turbidity, and DS18B20 temperature sensors that continuously monitor critical water quality parameters. These sensors transmit real-time data to the ESP32, where the values are processed and compared with predefined threshold levels.

The control layer consists of a 2-channel relay module connected to inlet and outlet water pumps, enabling automated water exchange when turbidity exceeds safe limits. The feeding mechanism is driven by a NEMA 17 stepper motor controlled through an A4988 motor driver. A 3D-printed auger screw mechanism ensures accurate and consistent dispensing of fish feed according to scheduled timings stored in the system.

For communication and remote monitoring, the ESP32 utilizes its built-in Wi-Fi module to transmit sensor data

to the Firebase Realtime Database. The cloud layer stores and synchronizes data, allowing users to monitor pond conditions through a mobile application developed using Kodular. Additionally, an ESP32-CAM module provides live video streaming for surveillance of pond activity. This multi-layered architecture ensures efficient data acquisition, automated control, remote accessibility, and enhanced reliability, making the system suitable for modern smart aquaculture applications.

5. EXPERIMENTAL RESULTS

The experimental evaluation of the proposed IoT-Enabled Aquaculture Management System was carried out to analyze its performance, reliability, and effectiveness under real-time aquaculture conditions. The primary objective of the testing phase was to assess the accuracy of sensor data acquisition, system responsiveness, stability of communication, and the efficiency of automated control mechanisms.

The system was deployed in a controlled aquaculture setup where multiple sensors were used to continuously monitor key water quality parameters, including temperature, pH, turbidity, and dissolved oxygen. The sensor readings were recorded at regular intervals and compared with standard measurement instruments to verify accuracy. The results indicated that the system provided consistent and reliable readings with minimal deviation, demonstrating its suitability for real-time monitoring.

To evaluate system responsiveness, different environmental conditions were artificially created by varying water parameters. When any parameter exceeded predefined threshold limits, the system successfully triggered appropriate control actions such as activating aerators for low dissolved oxygen levels, switching on water pumps for circulation, and regulating feeding mechanisms. The response time of the system was observed to be minimal, ensuring timely corrective actions and preventing adverse effects on aquatic life.

The communication performance was also analyzed by monitoring data transmission from the microcontroller to the cloud platform. The system successfully uploaded real-time data to the cloud database without significant delay or data loss. The mobile application interface was able to retrieve and display the data accurately, providing users with continuous remote monitoring capabilities. Instant alerts and notifications were generated whenever

abnormal conditions were detected, enabling prompt intervention by the user.

System stability was tested through continuous operation over extended periods. The system maintained reliable performance without major interruptions, demonstrating robustness and suitability for long-term deployment in aquaculture environments. Additionally, the automated feeding and control mechanisms contributed to reduced manual effort and optimized resource utilization.

Overall, the experimental results confirm that the proposed system operates efficiently and reliably in real-time conditions. It ensures accurate monitoring, rapid response to environmental changes, and seamless remote access. These outcomes demonstrate that the system is a practical, cost-effective, and scalable solution for improving productivity and sustainability in modern aquaculture practices.

6. FUTURE SCOPE

The proposed IoT Enabled Aquaculture Management System can be further enhanced by integrating advanced machine learning and data analytics techniques to enable predictive and intelligent decision-making. By analyzing historical sensor data, the system can forecast variations in water quality parameters, detect early signs of fish diseases, and optimize feeding schedules. This would help in improving productivity, reducing losses, and enabling proactive farm management rather than reactive control.

Further improvements can be achieved by incorporating additional sensors to monitor parameters such as ammonia, nitrate levels, and salinity, which play a crucial role in maintaining a healthy aquatic environment. The system can also be extended with computer vision technologies for monitoring fish behavior, growth rate, and health conditions. Integration of edge computing can reduce latency and ensure faster response times, making the system more reliable in remote areas with limited internet connectivity.

In addition, the scalability and sustainability of the system can be improved by supporting multi-pond monitoring with centralized control and advanced data visualization dashboards. The use of renewable energy sources such as solar power can make the system energy-efficient and suitable for off-grid deployments. These advancements can transform the proposed system into a fully autonomous and intelligent aquaculture management

solution, contributing to sustainable and large-scale aquaculture practices.

7. CONCLUSION

The proposed IoT Enabled Aquaculture Management System presents an effective and reliable solution for modern aquaculture practices by integrating real-time monitoring, automation, and remote accessibility. The system successfully monitors critical water quality parameters such as temperature, pH, turbidity, and dissolved oxygen using sensor-based technology, ensuring a healthy environment for aquatic organisms. By continuously tracking these parameters, the system minimizes the risks associated with manual monitoring and delayed intervention.

The implementation of automated control mechanisms, including aerators, water pumps, and feeding systems, enables timely corrective actions when environmental conditions deviate from optimal levels. Additionally, the integration of cloud connectivity and a mobile application allows farmers to monitor their aquaculture systems remotely and receive instant alerts, thereby improving operational efficiency and reducing manual effort. The experimental results demonstrate that the system performs reliably with accurate data acquisition, quick response time, and stable communication.

Overall, the proposed system provides a cost-effective, scalable, and user-friendly approach to aquaculture management. It enhances productivity, optimizes resource utilization, and supports sustainable farming practices. By leveraging IoT and smart automation technologies, this system offers a practical solution to address the challenges faced in traditional aquaculture and contributes to the advancement of intelligent and sustainable fish farming systems.

REFERENCES

1. M. A. Abid, M. Amjad, K. Munir, H. U. R. Siddique, and A. D. Jurcut, "IoT-Based Smart Biofloc Monitoring System for Fish Farming Using Machine Learning," *IEEE Access*, vol. 12, pp. 86333–86345, Apr. 2024, doi: 10.1109/ACCESS.2024.3384263.
2. J. Kumar, R. Gupta, S. Sharma, T. Chakrabarti, P. Chakrabarti, and M. Margala, "IoT-Enabled Advanced Water Quality Monitoring System for Pond Management and Environmental Conservation," *IEEE Access*, vol. 12, pp. 58156–58167, Apr. 2024, doi: 10.1109/ACCESS.2024.3391807.
3. N.-B.-V. Le, H. Woo, D. Lee, and J.-H. Huh, "AgTech: A Survey on Digital Twins Based Aquaculture Systems," *IEEE Access*, vol. 12, pp. 125751–125764, Aug. 2024, doi: 10.1109/ACCESS.2024.3443859.
4. N.-B.-V. Le and J.-H. Huh, "AgTech: Building Smart Aquaculture Assistant System Integrated IoT and Big Data Analysis," *IEEE Transactions on Agrifood Electronics*, vol. 2, no. 2, pp. 471–482, Sept.–Oct. 2024, doi: 10.1109/TAFE.2024.3416415.
5. J. Kristmundsson, Ø. Patursson, J. Potter, and Q. Xin, "Fish Monitoring in Aquaculture Using Multibeam Echosounders and Machine Learning," *IEEE Access*, vol. 11, pp. 108306–108316, Oct. 2023, doi: 10.1109/ACCESS.2023.3320949.
6. N. B. V. Le and J.-H. Huh, "Building-smart-aquaculture-assistant-systemintegrated-IoTs-and-big-data-analysis," 2023. [Online]. Available: <https://github.com/baovanle/Building-Smart-Aquaculture-Assistant-System-Integrated-IoTs-and-Big-Data-Analysis>.
7. J. G. Ferreira, L. Bernard-Jannin, A. Cubillo, J. L. E. Silva, G. P. J. Diedericks, H. Moore, M. Service, and J. P. Nunes, "From soil to sea: An ecological modelling framework for sustainable aquaculture," *Aquaculture*, vol. 577, Dec. 2023, Art. No. 739920.
8. R. M. M. Salem, M. S. Saraya, and A. M. T. Ali-Eldin, "An Industrial Cloud-Based IoT System for Real-Time Monitoring and Controlling of Wastewater," *IEEE Access*, vol. 10, pp. 6528–6540, Jan. 2022, doi: 10.1109/ACCESS.2022.3141977.
9. D. R. Prapti, A. R. Mohamed Shariff, H. Che Man, N. M. Ramli, T. Perumal, and M. Shariff, "Internet of Things (IoT)-based aquaculture: An overview of IoT application on water quality monitoring," *Rev. Aquaculture*, vol. 14, no. 2, pp. 979–992, Mar. 2022, doi: 10.1111/raq.12637.
10. P. McIntosh, L. T. Barrett, F. Warren-Myers, A. Coates, G. Macaulay, A. Szetey, N. Robinson, C. White, F. Samsing, F. Oppedal, O. Folkedal, P. Klebert, and T. Dempster, "Supersizing salmon farms in the coastal zone: A global analysis of changes in farm technology and location from 2005 to 2020," *Aquaculture*, vol. 553, May 2022, Art. No. 738046.
11. The State of World Fisheries and Aquaculture 2022, *Towards Blue Transformation*, FAO, Rome, Italy, 2022.

12. M. Singh, K. S. Sahoo, and A. Nayyar, “Sustainable IoT Solution for Freshwater Aquaculture Management,” *IEEE Sensors Journal*, vol. 22, no. 16, pp. 16563–16572, Aug. 2022, doi: 10.1109/JSEN.2022.3188639.
13. S. K. Viswanathan, S. Rajendran, S. K. Prashanth, and M. M. Ramya, “An Intelligent-IoT-Based Data Analytics for Freshwater Recirculating Aquaculture System,” *IEEE Internet of Things Journal*, vol. 9, no. 21, pp. 21345–21353, Nov. 2022, doi: 10.1109/JIOT.2022.3189726.
14. K. Rose, S. Eldridge, and L. Chapin. (Oct. 2015). *The Internet of Things: An overview*. Internet Society. Accessed: Nov. 20, 2021.
15. V. Saiz-Rubio and F. Rovira-Más, “From smart farming towards agriculture5.0: A review on crop data management,” *Agronomy*, vol. 10, no. 2, p. 207, 2020.