

# LORA Video Streaming in Rural Wireless Multimedia Sensor Networks

Mr. Ch. Pavan Kumar<sup>1</sup>, J. Manoja<sup>2</sup>, J. PenugondaShyam<sup>3</sup>, D. Gayathri<sup>4</sup>, Ch. Vasavi Priya<sup>5</sup>, Sk. Nasheed<sup>6</sup>

*Department of Electronics and Communication Engineering,  
PBR Visvodaya Institute of Technology & Science, Kavali (Autonomous),  
SPSR Nellore (Dt.), Andhra Pradesh – 524201, India*

\*\*\*

**Abstract** - This paper presents an integrated rural surveillance and environmental monitoring system that combines real-time video streaming with multi-sensor data acquisition using long-range, low-power LoRa communication. The proposed system utilizes an IP camera for continuous video surveillance, while an Arduino Uno interfaces with gas, fire, and DHT (temperature and humidity) sensors to monitor environmental conditions in real time. Sensor data is transmitted over a LoRa link to a remote receiver unit, enabling reliable communication in areas with limited or no conventional network infrastructure. To ensure timely response during critical situations, a GSM module is incorporated to automatically send SMS alerts to users when hazardous conditions such as fire, gas leakage, or abnormal temperature and humidity levels are detected. A push-button mechanism is also included for manual alert generation. The integration of video surveillance, environmental sensing, and long-range wireless communication into a unified platform overcomes the limitations of conventional rural monitoring systems that rely on short-range connectivity and non-integrated components. The system demonstrates improved reliability, extended coverage, low power consumption, and real-time situational awareness. It provides a cost-effective and scalable solution suitable for applications such as rural safety, smart village development, disaster management, and industrial monitoring in remote areas.

**Keywords:** LoRa Communication, Rural Surveillance, Environmental Monitoring, IoT, GSM Alerts, Wireless Sensor Network, Real-Time Monitoring.

## 1. INTRODUCTION

With the rapid growth of technology, monitoring and surveillance systems have become important for ensuring safety and proper environmental management. However, implementing these systems in rural and remote areas is challenging due to the lack of reliable communication infrastructure such as internet and Wi-Fi. Traditional systems are not suitable for long-distance communication and often consume high power. Rural areas are also more vulnerable to hazards like gas

leakage, fire accidents, and sudden changes in temperature and humidity, which can cause serious damage if not detected early.

To address these issues, this paper proposes a LoRa-based monitoring system that combines environmental sensing with real-time video surveillance. LoRa technology enables long-range communication with low power consumption, making it ideal for rural applications. The system uses gas, fire, temperature, and humidity sensors to continuously monitor environmental conditions, along with an IP camera for visual monitoring. A push button is included for manual alerts, and a GSM module is used to send SMS notifications during abnormal conditions. Overall, the proposed system provides a simple, cost-effective, and efficient solution for improving safety and monitoring in rural areas.

## 2. LITERATURE SURVEY

Recent research has extensively explored the use of LoRa technology for low-power, long-range communication in Internet of Things (IoT) applications, particularly for environmental monitoring and surveillance. The study titled “Multimedia Transmission over LoRa Networks for IoT Applications: A Survey of Strategies, Deployments, and Open Challenges” (2025) highlights that while LoRa is highly efficient for scalar data transmission, its application in multimedia communication is limited due to constraints such as low data rate, restricted payload size, and duty-cycle regulations. The authors emphasize that most existing implementations focus on image transmission, with limited work on video and audio, and propose techniques such as compression, fragmentation, and hybrid network architectures to enhance performance.

Similarly, the paper “Heterogeneous LoRa-Based Wireless Multimedia Sensor Network Multiprocessor Platform for Environmental Monitoring” (2019) addresses the challenge of balancing energy efficiency and computational capability in wireless multimedia sensor networks. It proposes a heterogeneous multiprocessor platform combining an ultra-low-power

microcontroller with a high-performance processor, enabling efficient multimedia data processing, adaptive system control, and reduced energy consumption while supporting inputs from cameras and microphones. Furthermore, the study “LoRa-Based Video Data

Transmission for Real-Time Monitoring of Pig Farm” (2023) demonstrates the practical feasibility of transmitting video data over LoRa networks by employing video compression techniques such as H.265 and segmenting data into smaller packets. The system achieved a transmission range of up to 2 km with low power consumption while maintaining acceptable video quality, confirming the potential of LoRa for real-time monitoring applications. Collectively, these studies indicate that although LoRa-based systems offer promising solutions for rural monitoring and multimedia applications, challenges related to limited bandwidth, energy optimization, and real-time performance still persist, thereby motivating the development of more efficient and integrated systems.

### 3. EXISTING SYSTEM

In traditional rural monitoring systems, surveillance and environmental monitoring are often handled separately. Video streaming is usually limited to short-range Wi-Fi or wired networks, making coverage in remote areas difficult. Environmental sensors such as gas, temperature, and fire detectors operate independently and may require local monitoring or frequent manual checking. Alerts are generally not automated, resulting in delayed response to hazardous conditions. These systems lack integration of long-range communication and real-time alerts, reducing their efficiency and reliability in rural environments.

**Limitations:** The primary constraint is the low data rate and limited payload size of LoRa communication, which restricts the transmission of high-quality real-time multimedia data, especially video and audio. Although compression and fragmentation techniques are used, they often introduce latency and reduce data quality. Many existing systems rely on complex architectures such as multi-hop networks, heterogeneous processors, or cloud-based platforms, which increase system complexity, cost, and maintenance requirements. Energy consumption also becomes a concern when handling continuous multimedia transmission, particularly in remote deployments with limited power sources. Additionally, most solutions focus either on environmental sensing or multimedia transmission, but lack full integration of both functionalities along with real-time alert mechanisms. Dependence on external infrastructure for video

streaming and data processing further limits their effectiveness in rural and remote areas. These challenges highlight the need for a simplified, energy-efficient, and fully integrated system for reliable monitoring and surveillance.

### 4. PROPOSED SYSTEM

The proposed system is designed as a LoRa-based rural surveillance and environmental monitoring platform that integrates sensing, communication, video monitoring, and alert mechanisms into a unified architecture. The system is divided into two main sections: the transmitter unit and the receiver unit, as illustrated in the block diagram.

At the transmitter side, an Arduino Uno microcontroller acts as the central processing unit, interfacing with multiple sensors such as a gas sensor, fire sensor, and DHT sensor for measuring temperature and humidity. These sensors continuously monitor environmental conditions and send real-time data to the microcontroller. A push-button switch is also connected to the transmitter unit, allowing users to manually trigger an alert during emergency situations. The processed sensor data is then transmitted using a LoRa module, which enables long-range wireless communication with low power consumption, making it suitable for rural and remote areas.

In addition to environmental sensing, an IP camera is deployed to provide real-time video surveillance of the monitored area. The camera operates independently over an internet or local network connection, enabling users to visually observe the environment alongside sensor data.

At the receiver side, another LoRa module is used to receive the transmitted data. The received information is processed and displayed on an LCD screen for continuous monitoring.

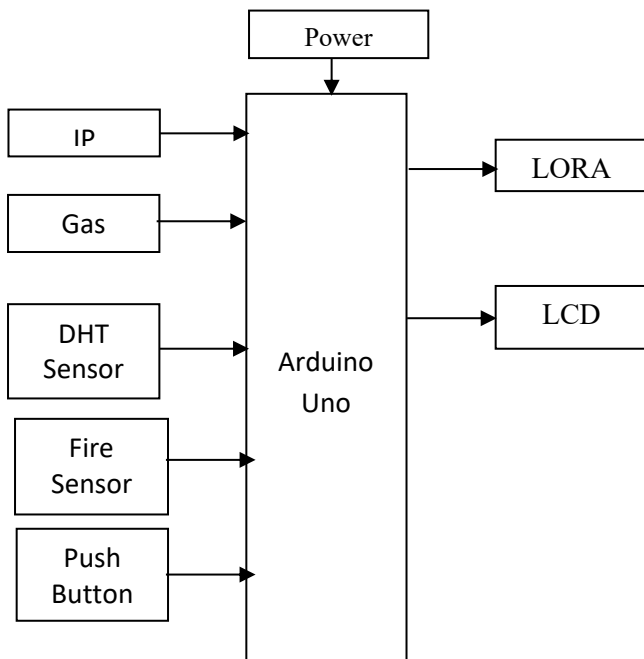

Fig 4.1 Block Diagram of The Proposed System (Transmitter)

A GSM module is integrated into the receiver unit to send SMS alerts to predefined users whenever abnormal conditions such as gas leakage, fire detection, or extreme temperature and humidity levels are identified. This ensures timely notification and quick response, even when users are not physically present at the location.

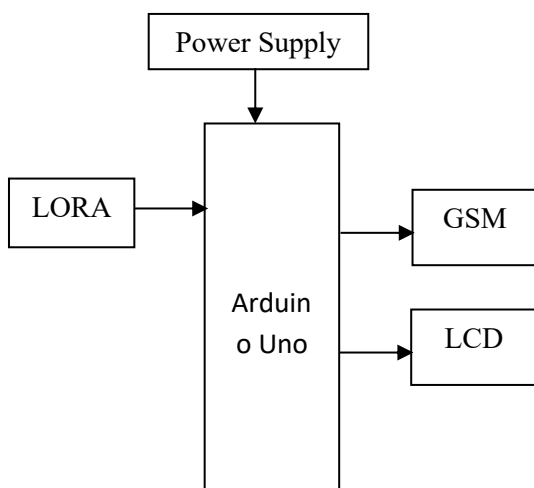

Fig 4.2 Block Diagram of The Proposed System (Receiver)

Overall, the proposed system combines long-range LoRa communication, real-time environmental sensing, manual alert functionality, video surveillance, and GSM-based notification into a single efficient platform. This integrated approach improves reliability, reduces the need for manual monitoring, and provides a

cost-effective and energy-efficient solution for rural safety, environmental monitoring, and smart village applications

### 5. IMPLEMENTATION AND RESULTS

The proposed system was implemented by integrating both hardware and software components to achieve real-time environmental monitoring and alerting. The system consists of two main sections, namely the transmitter and receiver, which communicate using LoRa technology for long-range data transmission as shown below in fig 5.1.

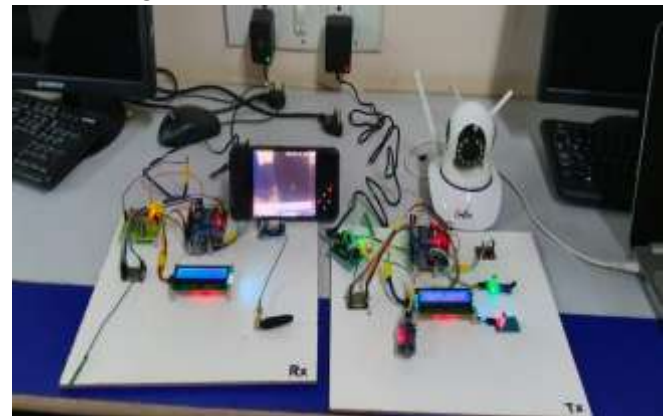

Fig 5.1 Implementation of Proposed system

In the transmitter section, an Arduino Uno microcontroller is used as the central control unit and is interfaced with a gas sensor for detecting gas leakage, a DHT11 sensor for measuring temperature and humidity, and a fire sensor for detecting flame presence. A push button is also included for manual triggering of alerts. These sensors continuously monitor environmental conditions, and the collected data is processed by the Arduino based on predefined threshold values. The processed data is then transmitted wirelessly using the LoRa module. An IP camera is also deployed in the monitoring area to provide real-time video streaming, enabling users to remotely observe the environment when required. In the receiver section, another Arduino Uno connected to a LoRa module receives the transmitted data and processes it to display real-time information on an I2C-based LCD. A GSM module is integrated to send alert messages to predefined mobile numbers whenever an abnormal condition is detected, where the system first displays a warning message on the LCD and then sends the GSM alert. The entire system is developed using the Arduino IDE with embedded C programming, incorporating functionalities such as sensor initialization, continuous data acquisition, wireless communication, condition monitoring, LCD display control, and GSM-based alert notification. Thus, the implementation effectively combines sensing, communication, and alert

mechanisms to ensure reliable and continuous monitoring of environmental conditions.

The proposed LoRa-based rural monitoring and surveillance system was successfully implemented and tested under different environmental conditions to evaluate its performance. The system effectively monitored parameters such as temperature, humidity, gas leakage, and fire detection using the integrated sensors. The sensor readings were accurately captured by the Arduino Uno and transmitted to the receiver unit via LoRa communication without significant data loss.

The LoRa module demonstrated reliable long-range communication, maintaining stable data transmission over distances of up to approximately 1–2 km in open rural conditions. The system exhibited low power consumption, making it suitable for continuous operation in remote areas. Real-time data was displayed on the receiver-side LCD, allowing users to monitor environmental conditions efficiently.

The GSM module performed effectively by sending instant SMS alerts to users when abnormal conditions such as gas leakage, fire detection, or extreme temperature and humidity levels were observed. The alert system responded promptly, ensuring timely notification and enabling quick preventive action. Additionally, the push-button mechanism successfully triggered manual alerts during emergency situations as shown in below fig5.2.

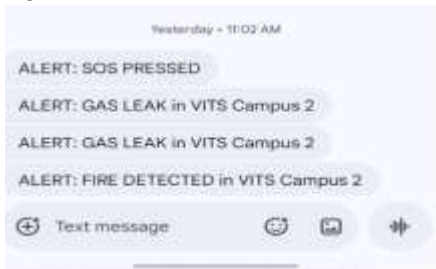

Fig 5.2 Alert messages received in user mobile

The IP camera provided continuous video surveillance, enabling real-time visual monitoring of the environment. Although LoRa was not used for direct video transmission, the integration of video monitoring with sensor data enhanced overall situational awareness as shown in below figure 5.3.



Fig5.3 Access of IP Camera through user mobile Phone .

Overall, the system demonstrated reliable performance, efficient communication, and accurate detection of environmental hazards. The integration of LoRa communication, multi-sensor monitoring, GSM-based alerting, and video surveillance provides a cost-effective and scalable solution for rural and remote area applications. However, limitations such as LoRa bandwidth constraints and dependency on GSM network availability were observed, which can be addressed in future enhancements.

## 6. DISCUSSION

The proposed LoRa-based monitoring system effectively addresses the limitations of existing rural surveillance systems. One of the key challenges of LoRa communication is its low data rate and limited bandwidth. This issue is managed in the proposed system by using LoRa only for transmitting sensor data, while real-time video monitoring is handled separately through an IP camera. This hybrid approach improves system efficiency and avoids overloading the communication network. In addition, the use of an Arduino-based architecture ensures low power consumption, making the system suitable for rural areas where energy resources are limited.

The system also demonstrates reliable performance in detecting environmental hazards such as gas leakage, fire, and temperature variations. The GSM module provides quick alert messages to users, ensuring timely response during emergency situations. The integration of sensors, LoRa communication, GSM alerts, and video monitoring improves overall system functionality and situational awareness. However, the system has some limitations, such as dependence on GSM network availability and the inability of LoRa to support high-data-rate applications like video transmission. Despite these limitations, the system provides a practical and efficient solution for rural monitoring applications.

## 7. CONCLUSION

The proposed LoRa-based rural surveillance and environmental monitoring system provides an effective solution for real-time monitoring in remote areas. By integrating environmental sensors, LoRa communication,

GSM alerts, and an IP camera, the system ensures reliable data collection, long-range transmission, and timely alert generation. The use of low-power components makes the system suitable for rural deployment, where power and communication infrastructure are limited.

The system successfully detects hazardous conditions such as gas leakage, fire, and abnormal temperature and humidity, and sends instant notifications to users. Although limitations such as LoRa bandwidth constraints and dependence on GSM networks exist, the overall system performance is efficient and reliable. Future improvements can include cloud integration, mobile application support, and advanced data analysis to enhance system functionality and scalability.

## ACKNOWLEDGEMENT

The authors sincerely thank Mr. Ch. Pavan Kumar (Assistant Professor, ECE, PBR VITS Kavali) for his guidance, Dr. R. Sravanthi (Professor & HoD, ECE) for providing facilities, and Dr. V. Anil Kumar (Principal, PBR VITS Kavali) for the academic environment that enabled this work.

## REFERENCES

- [1] De, S., Jalajamony, H. M., Adhinarayanan, S., Joshi, S., Upadhyay, H., & Fernandez, R., "Multimedia Transmission over LoRa Networks for IoT Applications: A Survey of Strategies, Deployments, and Open Challenges," *Sensors*, vol. 25, no. 23, p. 7128, 2025. [Google Scholar] [CrossRef]
- [2] García, S., Larios, D. F., Barbancho, J., Personal, E., Mora-Merchán, J. M., & León, C., "Heterogeneous LoRa-Based Wireless Multimedia Sensor Network Multiprocessor Platform for Environmental Monitoring," *Sensors*, vol. 19, no. 16, p. 3446, 2019. [Google Scholar] [CrossRef]
- [3] Reza, M. N., Ahmed, S., Islam, S., Kabir, M. S. N., Song, M., Kim, G., & Chung, S.-O., "LoRa-Based Video Data Transmission for Real-Time Monitoring of Pig Farm," in *Proceedings of the Korean Society for Agricultural Machinery (KSAM) Conference, 2023*. [Google Scholar]
- [4] Hatfield, J.L.; Prueger, J.H. Temperature extremes: Effect on plant growth and development. *Weather Clim. Extrem.* 2015, 10, 4–10. [Google Scholar] [CrossRef]

- [5] Dauvergne, P.; Clapp, J. Researching global environmental politics in the 21st century. *Glob. Environ. Polit.* 2016, 16, 1–12. [Google Scholar] [CrossRef]
- [6] Zanne, A.E.; Tank, D.C.; Cornwell, W.K.; Eastman, J.M.; Smith, S.A.; Fitzjohn, R.G.; McGlenn, D.J.; O'Meara, B.C.; Moles, A.T.; Reich, P.B.; et al. Three keys to the radiation of angiosperms into freezing environments. *Nature* 2014, 506, 89. [Google Scholar] [CrossRef] [PubMed]
- [7] Schwartz, M.D. Advancing to full bloom: Planning phenological research for the 21st century. *Int. J. Biometeorol.* 1999, 42, 113–118. [Google Scholar] [CrossRef]
- [8] Larios, D.F.; Rodríguez, C.; Barbancho, J.; Baena, M.; Simón, F.; Marín, J.; León, C.; Bustamante, J. Intelligent monitoring system for bird behavior study. In *Communications in Computer and Information Science, Proceedings of the International Conference on E-Business and Telecommunications, Rome, Italy, 24–27 July 2012*; Springer: Berlin/Heidelberg, Germany, 2014. [Google Scholar]
- [9] Luque, J.; Larios, D.F.; Personal, E.; Barbancho, J.; León, C. Evaluation of MPEG-7-based audio descriptors for animal voice recognition over wireless acoustic sensor networks. *Sensors (Switz.)* 2016, 16, 717. [Google Scholar] [CrossRef] [PubMed]
- [6] Zanne, A.E.; Tank, D.C.; Cornwell, W.K.; Eastman, J.M.; Smith, S.A.; Fitzjohn, R.G.; McGlenn, D.J.; O'Meara, B.C.; Moles, A.T.; Reich, P.B.; et al. Three keys to the radiation of angiosperms into freezing environments. *Nature* 2014, 506, 89. [Google Scholar] [CrossRef] [PubMed]
- [7] Schwartz, M.D. Advancing to full bloom: Planning phenological research for the 21st century. *Int. J. Biometeorol.* 1999, 42, 113–118. [Google Scholar] [CrossRef]
- [8] Larios, D.F.; Rodríguez, C.; Barbancho, J.; Baena, M.; Simón, F.; Marín, J.; León, C.; Bustamante, J. Intelligent monitoring system for bird behavior study. In *Communications in Computer and Information Science, Proceedings of the International Conference on E-Business and Telecommunications, Rome, Italy, 24–27 July 2012*; Springer: Berlin/Heidelberg, Germany, 2014. [Google Scholar]
- [9] Luque, J.; Larios, D.F.; Personal, E.; Barbancho, J.; León, C. Evaluation of MPEG-7-based audio descriptors for animal voice recognition over wireless acoustic sensor networks. *Sensors (Switz.)* 2016, 16, 717. [Google Scholar] [CrossRef] [PubMed]