

Review on IoT-Enabled Smart Ultrasonic Radar for Real-Time Object Detection and Intelligent Tracking

Dr. D. D. Dhawale

Assistant Professor,

*Department of Electrical
Engineering, Priyadarshini
College Of Engineering Nagpur,
Maharashtra, India*

Gaurav. A. Meshram

Student

*Department of Electrical
Engineering, Priyadarshini
College Of Engineering Nagpur,
Maharashtra, India*

Dipanshu. S . Mendhe

Student

*Department of Electrical
Engineering, Priyadarshini
College Of Engineering Nagpur,
Maharashtra, India*

Ravindar Yerrola

Student

*Department of Electrical
Engineering, Priyadarshini
College Of Engineering Nagpur,
Maharashtra, India*

Yashshree Ghadle

Student

*Department of Electrical
Engineering, Priyadarshini
College Of Engineering Nagpur,
Maharashtra, India*

Soniya Gajbe

Student

*Department of Electrical
Engineering, Priyadarshini
College Of Engineering Nagpur,
Maharashtra, India*

Abstract- The safety of railway transportation is a burning issue because of the growing number of rail traffic, the deteriorating infrastructure and constant track-related failures. Track cracks and structural faults are among other reasons of railway accidents that cause derailments and disruption of services. The old methods of manual inspection are time consuming, labor intensive and can be subject to human error and as such, cannot be used effectively in proving continuous monitoring. The latest trends in the embedded systems, wireless sensor networks, and Internet of Things (IoT) technologies have made it possible to design smart railway track monitoring systems. This review paper is a detailed discussion of the currently available railway track crack detection systems that are grounded on the IoT, embedded systems, vibration sensors and wireless monitoring systems. It is a critical analysis of sensor technologies, data transmission techniques, detection precision, cost-efficiency, and scalability of the system. Moreover, the article identifies gaps in research in real-time monitoring, remote reporting and fault localization. This review will shed light on how effective, cost-effective and scalable railway track crack detection systems can be designed to promote operational reliability and passenger safety by synthesizing findings of recent research on this topic. The Development of an IoT-Based Smart Railway Accident Detection System based on Ultrasonic Sensing Technology tries to improve the safety of

railways by providing real-time monitoring and automatic detection of faults. The ultrasonic sensors identify any obstacles, cracks or abnormalities on the railway tracks and the IoT technology sends the alerts to a control center. The system facilitates the early identification, minimization of accidents, and efficient maintenance and safety management of the railways.

Keywords— *Railway Track Monitoring, Crack Detection, Internet of Things (IoT), ultrasonic sensor, IR Sensors, Railway Safety etc.*

I. INTRODUCTION

Rail transport is a critical component in the development of the economy, movement of freights, and passenger transportation within the globe. In other countries with large railway systems like India, integrity of the tracks is a big problem as the rails are old and the traffic density is very high with the environmental factors and poor maintenance schedules. Among the most foremost causes of railroad derailments and the failure of infrastructure are track defects, especially cracks and fractures. Recent research indicates that the probability of accidents and maintenance costs are highly reduced by identifying rail defects early [1]. Old-fashioned approaches to inspecting the railway tracks are based on manual inspection and planned maintenance procedures. Experts use physical inspection of the tracks to detect any visible cracks, misalignments, and deformities. Manual inspection is however time consuming, labor

intensive and prone to human error. Also, the rate of inspection is minimized particularly in remote or busy locations, which would lead to the possibility of faults going undetected [2]. Such restrictions have inspired scientists to research the automated and intelligent monitoring systems. The development of embedded systems and sensor technologies has led to the development of automated monitoring of the railway track. Embedded systems with sensors to detect cracks can constantly check the track conditions and give instant notifications when anomalies are detected. Memon et al. [3] suggested embedded fault detection system which can detect anomaly in a railway in real time and show better reliability than the traditional inspection process. These systems lower their reliance on human intervention and promote efficiency in their operations. With the advent of the Internet of Things (IoT), the railway monitoring applications have also become revolutionary. IoT allows the acquisition of data, wireless transmission, cloud storage, and remote monitoring. In [1], Revathi et al. designed an IoT-based railway crack detection system that involves the combination of sensors and wireless communication modules to report faults in real-time. They emphasize on the significance of continuous surveillance and centralized monitoring as a way of preventing derailments. The IoT-based systems enable railway.

Rail defect detection has also been achieved by wireless sensor networks (WSNs) that have been extensively studied. Zhao et al. [4] surveyed different wireless sensor-based methods and classified them according to sensing methodologies of ultrasonic testing, vibration analysis, acoustic emission, and infrared sensing. The technologies have different benefits in accuracy of detection, price, and the possibility of deployment. Nonetheless, issues like power consumption, communication latency, and environmental interference are still aspects to be done in research. Recent developments in multi-sensor fusion and vibration-based monitoring have shown promising results. Salim et al. [2] introduced a cost-efficient real-time monitoring system with the help of vibration sensors and optimized strategies of sensors placement. They found that their study had high detection accuracy and better efficiency in detecting incoming trains and track anomalies. Multi-sensor fusion increases reliability through a combination of multiple data streams, which minimizes false positives and increases detection accuracy. The ultrasonic sensing technology is capable of accurately identifying obstacles and anomalies on railway tracks. Internet of Things (IoT) can be integrated, which allows data to be transmitted in real-time and be monitored remotely. The proposed IoT-based system assists in identifying accidents or monitoring faults in a timely manner and sending notifications to the authorities of the railroad. This method enhances the safety of railways,

efficiency.



Figure 1. Crack on track, Manual crack detection by human and railway accidents

Despite significant advancements, several challenges persist in the implementation of automated railway crack detection systems. High deployment costs, integration complexity, power management issues, and limited scalability hinder large-scale adoption. Furthermore, many existing systems lack precise fault localization and rapid alert mechanisms required for immediate corrective action. There is a need for cost-effective, scalable, and energy-efficient IoT based systems with real time remote reporting and accurate crack detection. The goal of this paper is to critically examine the latest contributions to the research on the system of crack detection in railway tracks and the development of IoT-based, sensor-based, embedded systems, and wireless communication models. This study will make it possible to create advanced, reliable and intelligent railway monitoring systems that will improve the safety and efficiency of passengers and operations by establishing the current trends, limitations and research gaps.

II. PROBLEM IDENTIFICATION

Track cracks, fractures and structural defects are major safety problems in the railway transportation systems that are usually detected at an advanced stage when they have caused serious damage. The manual checking systems that are used traditionally are labor-intensive, time-consuming, and prone to human error which limits their efficiency in continuous monitoring. The acceleration in train speed, high axle loads, and the age of the railroads compounds the process of track deterioration. Current automated systems are either

costly, complicated or do not provide real-time remote reporting. Moreover, a lot of monitoring strategies do not offer accurate fault localization and immediate alerting systems, postponing corrective measures. The rail degradation is also caused by environmental factors like temperature variation, vibration and corrosion. This lack of cost-effective, scalable, and IoT-integrated system to detect cracks contributes to the threat of derailments, disruptions in service, and economic loss. Consequently, strong demand exists to have an intelligent, real-time and automated rail track monitoring solution to improve safety and operational reliability.

III. LITERATURE REVIEWS

A. Literature Survey

1. Revathi, D.M., et al. (2024), The authors suggested an IoT-based model of crack detection on the railway with the use of IR sensors, a microcontroller, and a wireless communication unit. Monitoring is carried out continuously by the system and real-time alerts are sent to a centralized control unit. The experimental validation indicated a better detection efficiency than when manually inspecting the product. The research indicates less human dependency and quicker response. The suggested architecture is affordable and can be used in large railway networks. Nonetheless, practical limitations were found to be environmental noise and sensor alignment problems. The study highlights the significance of IoT implementation in remote monitoring and preventive maintenance measures in railroads.

2. Salim, S.I., et al. (2025), The present study proposed a vibration-based monitoring system based on multi-sensor fusion and optimal sensor positioning schemes. The system attained a detection accuracy of around 95% of track anomalies and train detection within 1km. The authors used meta-heuristic algorithms to decrease the deployment cost without sacrificing the reliability. Preventive maintenance planning was enhanced by real-time data acquisition and processing. The paper mentions that there are pros to the use of vibration sensing in conjunction with wireless communication. for better efficiency.

3. Memon, T.R., et al. (2023), The work describes a microcontroller-built system to identify rail faults in real-time. Sensors constantly check the state of the tracks and raise an alarm when anomalies are observed. The system enhances quickness in the inspection and minimizes manual reliance. Findings indicate higher operational efficiency and reliability than the traditional inspection procedures. The study

also talks of integration with wireless modules to report remotely. Practical issues identified were environmental sustainability and sensor maintenance. The research establishes that embedded systems are important in the modernization of railway monitoring systems.

4. Zhao, Y., et al. (2022), This review divides rail defect detection technologies into ultrasonic, vibration, acoustic emission, and infrared-based systems. The wireless sensor networks are seen as a potential solution to continuous monitoring. The authors examine the accuracy of detection, the scalability and the efficiency of communication. The paper highlights the importance of energy saving communication schemes and real time data processing algorithms. Despite the flexibility of wireless systems in monitoring, issues like power consumption, environmental interference, and signal attenuation continue to be challenges. The review points out the integration of IoT as a future of management of the intelligent infrastructure of railway.

5. Castillo-Mingorance, J.M., et al. (2020), This paper is a critical review of sensor technologies to monitor railways, such as strain gauges, accelerometers, fiber optic sensors, and ultrasonic sensors. Continuous monitoring systems proved to enhance efficiency in maintenance and sustainability of infrastructure. The authors underline predictive maintenance, which is backed up by real-time sensing. Although smart sensors minimize the risk of failures, its high cost of installation and maintenance is a limiting factor in its use. It was proposed to integrate with IoT platforms to provide better data management. The research offers useful information as to how to shift to intelligent continuous monitoring systems, as opposed to periodic inspection.

6 Khan, A., & Sharma, R. (2021), The authors developed a smart IoT-based railway monitoring prototype that is based on sensors and GSM communication modules. The system identifies cracks and reminds the railway authorities through SMS. It saves on inspection time, and it increases safety. Experimental results demonstrate reliable crack detection in small-scale models. The research is affordability and simplicity oriented and hence it fits in the developing regions. Nonetheless, scalability and the integration with cloud-based monitoring systems need to be improved. The study has identified IoT as a feasible means of automating railways.

7. Kumar, V., & Patel, S. (2022), This study has introduced a sensor-based embedded system that has the potential to detect faults on railroads in real-time. The system employs several sensors to check cracks, misalignments and structural weaknesses. Wireless modules are used to send real time alerts. There is better speed and reliability of detection in the study. The authors focus on cost-saving and modular design to be easily deployed. Difficulties in terms of severe environmental conditions and sensor calibration were detected. The study will help improve the safety of railway systems by incorporating automation technologies.

8. Li, H., et al. (2021), The article describes a wireless sensor network architecture to detect faults on the railway tracks. Vibration and strain data is gathered by sensors and sent to a central server to be analyzed. Anomaly detection is used by using machine learning algorithms. Findings show high accuracy and low false alarms. The study brings out scalability and remote monitoring features. Nonetheless, the power consumption and network stability are still a major issue. To enhance sustainability, the study suggests the incorporation of energy-efficient IoT communication protocols in the study.

9. Sharma, P., et al. (2023), This paper suggests an IoT-enabled rail health monitoring system that combines cloud computing and real-time analytics. The system gathers the information of distributed sensors and conducts analysis of predictive maintenance. The experimental validation shows the extra reliability and early fault detection. The cloud platform allows monitoring and data visualization to be centralized. The authors emphasize enhanced safety and maintenance planning. However, data security and communication latency are cited as issues. The paper highlights the need to incorporate IoT with analytics in next-generation railway safety systems.

10. Ahmed, R., et al. (2022), This study aims at detecting the vision-based railway cracks through image processing algorithms. Images of tracks are taken by cameras on inspection vehicles, and digital image processing methods determine the presence of cracks. The method enhances the detection accuracy over manual inspection. The system helps in automated reporting and less time on inspection. There are, however, some high computational demands and sensitivity to lighting conditions that restrict performance. The study suggests combining image processing with IoT and sensor-based systems for

improved reliability and scalability in real-time railway monitoring.

B. Literature Summary

Recent research on railway track crack identification focuses on the shift in the manual inspection process to automated and IoT-enabled monitoring systems. Embedded systems, infrared sensors, vibration analysis, ultrasonic testing and wireless sensor networks have been studied by researchers in the field of real-time rail defects detection. With IoT integration, remote monitoring, centralized data storage, as well as speedy transmission of alerts is made possible. Multi-sensor fusion methods have shown enhanced accuracy and less false.

detection rates. A number of studies indicate a detection efficiency of over 90% which notes the effectiveness of smart monitoring frameworks. Nevertheless, most of the solutions have shortcomings including high costs of installation, power management issues, environmental interference and lack of scalability. Generally, the literature suggests that there has been a lot of advancement in intelligent railway safety systems, but practical implementation issues still exist in the realisation of reliable, cost efficient and large scale deployment in large railway networks.

C. Research Gap

Although the IoT-based railway monitoring systems have been developed, there are still some gaps in research. Most of the current models are more concerned with laboratory testing as opposed to large-scale deployment in reality. Most systems do not properly handle accurate fault localization and position tracking using GPS. The research needs to be done on power efficiency and long-term survival of sensors in adverse environmental conditions. Moreover, there is a low level of integration with cloud analytics and predictive maintenance systems. The cost of implementation is high and system architecture is complicated making it difficult to use in the developing regions. Mechanisms of real-time response that can automatically halt trains are not commonly installed. It also has a deficiency of standardized communication protocols to facilitate smooth passing of data. Thus, an economical, scalable, energy-saving and fully automated crack detecting system with accurate reporting of faults is still required.

IV. METHODOLOGY

A. Proposed System

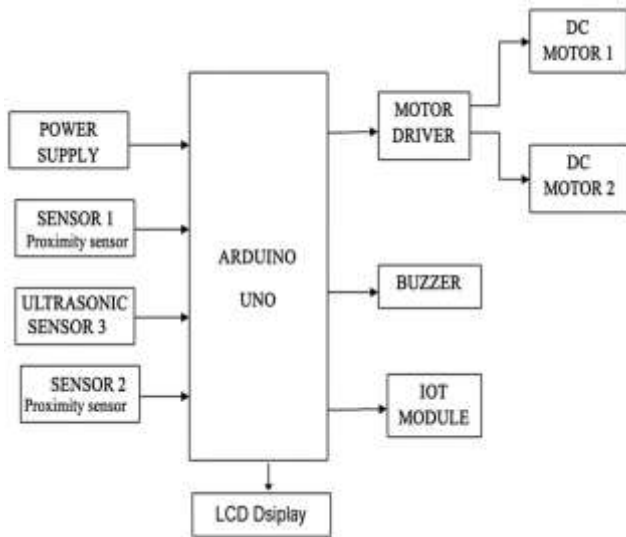

Figure 2. Proposed System

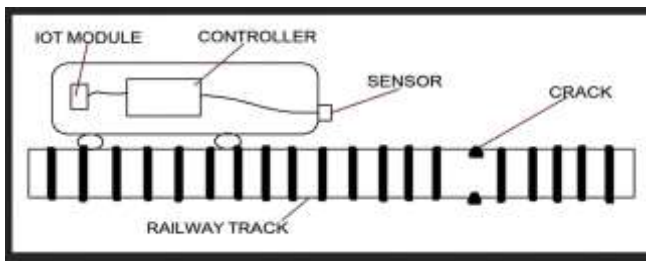

Figure 3. Functional Diagram

B. Working Principle

The design entails the automatic surveillance of railway tracks with cracks and structural defects via ultrasonic sensor installed with the IoT technology. Ultrasonic sensor modules place them below the mobile inspection vehicle to scan the surface of the railway track continuously.

- Upon activation of the system when the microcontroller is powered ON, the motor is activated and the inspection vehicle is able to run along the railway track.
- The ultrasonic sensor continuously sends ultrasonic high-frequency waves to the track's surface.
- Normal conditions Under normal conditions, the reflected ultrasonic waves bounce back within a given time range and this implies that the track is healthy and intact.
- When there is a crack, gap or structural fault, the pattern of the reflected signal or echo time is altered drastically.
- The microcontroller compares the distance and the echo time in real time and determines abnormalities.

- When a crack or fault is detected, the microcontroller will immediately shut down the motor to avoid any further motion and minimize the risk of accidents.
- At the same time, the IoT module gathers the fault data (location and status) and sends it to the central monitoring station.
- The system also uses a buzzer and LED indicators to give real time on site notifications.
- A cloud-based web interface sends real-time information to the control room, allowing railway authorities to promptly take corrective measures.
- Why: This automated ultrasonic based monitoring system will have a higher detection rate, less man power will be spent in inspection and the safety of the railways will be greatly increased.

C. Main Features

- Ultrasonic-Based Detection: This is the use of ultrasonic sensors to precisely identify obstacles, cracks, and abnormalities on the railway tracks on the fly.
- IoT Integration: allows permanent monitoring and transmitting data in real-time to a distant control center using wireless communication.
- Real-Time Alerts: Immediately notifies the railway authorities whenever faults or possible accidents are detected.
- Automated Operation: Reduces the human factor through automation of the detection, monitoring and alert systems.
- Accident Prevention Mechanism: Gives a warning signal in advance to minimize the chances of derailments and collisions.
- Remote Monitoring System: Makes the track conditions monitored by the railway officials via a web interface or a mobile interface.
- Low-Cost Implementation: It is structured using low-cost parts, making it fit in large scale applications.
- Energy Efficient System: Power efficiency through battery-powered modules to allow full functionality.

Scalability: Scalable and can be incorporated into large scale railway systems.

- Strong Performance: Can perform well in different environmental conditions like dust, rain, and change in temperatures.

D. Hardware Used :

- Ultrasonic Sensor (HC-SR04): It is a sensor that works with sound waves to measure the distance to the obstacle, cracks or any other anomaly on the tracks to identify it with high accuracy.
- Microcontroller (Arduino UNO / ESP32): The central processing unit that processes sensor data, runs logic and manages system operations.
- IoT Module (ESP8266 / ESP32 Wi-Fi): Allows a wireless connection and transmits real-time data to the control room or cloud platform.
- DC Motor (12 V, 30 RPM): Propels the inspection vehicle smoothly up the railroad track to keep it constantly monitored.

Motor Driver (L298N): A motor driver controlled by microcontroller commands, which determine motor direction and speed.

Battery (12V, 2Ah): This is used to supply power to all the electronic components so that the system does not stop functioning.

- Buzzer & LEDs: Provide instant audible and visual alerts when faults or obstacles are detected.
- Chassis/Vehicle Frame: Frame that supports mechanical assembly and movement of the system on the railway tracks.
- E. Software Used
- Arduino IDE: To program microcontroller functions and interface sensors.
- Embedded C: The default code language to control hardware.
- Cloud Platform (Thingspeak): Saves and plots patient health information offsite.
- Mobile server: Enables doctors to have real-time access to patient information.
- Data Analytics Tools: Assist in trend analysis and report-generation to improve healthcare insights.

V. ADVANTAGES AND APPLICATIONS

A. Advantages:

- Offers real-time crack and obstacle detection in railway tracks.
- Minimizes reliance on manual inspection and human involvement.
- Reduces risk of derailments and railway accidents.

- Facilitates real-time alerting using the IoT.
- Inexpensive and able to operate over large railway systems.
- Provides quicker response and preventive maintenance.
- Enhances reliability in operation and safety of passengers.
- Helps in constant surveillance in distant and busy locations.

B. Applications:

- Constant surveillance of railway lines both in urban and rural regions.
- Installation in high speed railways to increase safety.
- Metro rail and suburban railway systems.
- Connection with centralized railway control rooms.
- Bridge, tunnel and critical rail section monitoring.
- Preventive maintenance planning and asset management.
- Live fault reporting of the railway authorities.
- Smart Infrastructure development Train smart railway infrastructure development.

VI. CONCLUSION

The development of an IoT-based smart railway accident detection system with the implementation of ultrasonic sensing technology is effective and reliable in enhancing the efficiency of railways in terms of safety and monitoring.

The proposed system will allow detecting obstacles, cracks, and possible accident conditions in real-time on railway tracks by combining ultrasonic sensors with IoT and embedded systems.

This system is a more effective way of preventing human error than the manual inspection methods used in traditional inspection. It also offers continuous monitoring and reacts quickly to faulty conditions.

- IoT technology enables immediate transmission of information to a control center, and railway authorities can take timely preventive measures. The system is affordable, scalable, and can be installed on large railway systems, including remote and high-risk locations. Its capability to issue early warnings

greatly helps mitigate the risks of derailments and collisions.

- Altogether, the suggested system will increase operational reliability and facilitate predictive maintenance and passenger safety. It is a great leap toward creating smart railway infrastructure and modernizing railway monitoring systems with sophisticated sensing and communication technologies.

VII. REFERENCES

- [1] D. M. Revathi, et al., IoT Based Railway Track Crack Detection System, SSRN Electronic Journal, 2024.
- [2] S. I. Salim, et al., "A Cost-Effective Real-Time Rail Track Monitoring System, Scientific Reports, 2025.
- [3] T. R. Memon, et al., "Embedded System Development in Detection of Railway Faults, Procedia Computer science, vol. 137, no. 2, pp. 1245-1270, 2023.
- [4] Y. Zhao, et al., Review on Rail Defect Detection Systems using Wireless Sensors, vol. 22, no. 17, p. 6358, 2022.
- [5] J. M. Castillo-Mingorance, et al., A Critical Review of Sensors, Continuous Monitoring of Railway Tracks, Sustainability, vol. 12, no. 22, p. 9428, 2020.
- [6] A. Khan and R. Sharma, Smart Railway Track Monitoring System using IoT, International Journal of Recent Technology and Engineering (IJRTE), vol. 10, no. 5, pp. 423–430, 2021.
- [7] V. Kumar and S. Patel, Real-Time Railway Fault Detection with Embedded Systems and Sensors, Journal of Transportation Engineering, vol. 148, no. 3, p. 04021048, 2022.
- [8] Kamble, S.B. et al., "Railway Accident Prevention System for Collision Avoidance, Signals and Rail Track Detection," *International Journal of Creative Research Thoughts (IJCRT)*, vol. 13, no. 4, pp. b591-b597, Apr. 2025.
- [9] Ankitha et al., "RAILWAY TRACK CRACK DETECTION," *International Journal of Creative Research Thoughts (IJCRT)*, vol. 12, no. 5, pp. 189-195, May 2024.
- [10] Anil, M.D. et al., "Advanced Railway Accident Prevention System Using Sensor Networks," *International Journal of Advanced Research in Computer and Communication Engineering*, vol. 3, no. 5, May 2014.