

Review Paper on Low Cost Scada System for Micro Industry

Prof.Saurabh Lawate¹, Shruti S.Thulkar², Khushal Giradkar³, Avinash G.More⁴,

Vaishnavi Shinde⁵, Krutika Parate⁶, Ashish A.Bhanarkar

Vidarbha Institute of Technology,Uti,Nagpur

Abstract - The main objective of the project is to use the SCADA system to control data in real time. It is necessary to monitor all the processes and control the elements related to them because many processes are running simultaneously in large enterprises. We can achieve this goal by using technology such as Wireless SCADA (Supervisory Control and Data Analysis). The AT89S52 microcontroller is interfaced with temperature sensors. The microcontroller wirelessly transmits data continuously from the sensors, which are then received via a USB type trans-receiver connected to a PC or laptop. The computer software that records the data into a file and displays it on the front panel of the PC or laptop is loaded. On the SCADA screen, we can change the parameters such as the setting, the low limit, and the high limit. The microprocessor sends instructions to the appropriate relay as soon as the temperature sensor drops below a predetermined level. In response to their sensors, the field devices connected by the communicator are switched from ON to OFF. For the purpose of making the alarm sound on the PC when there is a malfunction, there are more restrictions and lower options. Thus SCADA can be used to control processes accurately and safely at hazardous locations. On the SCADA screen, we can change the parameters such as the setting, the low limit, and the high limit

Key Words: SCADA, Working Strategy, Future Scope

1.INTRODUCTION

This SCADA (Supervisory Control and Data Acquisition) is an integration of software and hardware components that enable remote or local control and supervision of industrial or other activities. The SCADA unit makes it easy and simple to observe and manage every aspect of the production process. The SCADA system is currently used frequently, and its use is expanding every day, but small and medium-sized businesses cannot afford to use it to monitor their plant processes due to the higher cost. If making wired connections to a remote location is too expensive or takes too long, a wireless SCADA is required. Its Wireless technology, which has become more popular in the IT industry recently, may also be appropriate for industrial control networks, offering solutions with high return on investment for safety, control, and diagnostics. Power-efficiency, timeliness, and scalability also present some potentially attractive properties for supporting large-scale ubiquitous computing applications. It is evident from managing the transition to wireless that common wireless protocols such as Wi-Fi and Bluetooth can be used in manufacturing settings.

2. OBJECTIVE

The goals of SCADA (Supervisory Control and Data Analysis) generally include: Automation of business processes: The main goal of a SCADA system is to automate business processes business, improve efficiency, and reduce the impact of the book. Real-time monitoring and control: The SCADA system provides monitoring and control of various industries and assets, enabling operators to respond quickly to changes. Improve process efficiency: The data collected by the SCADA system can be analyzed to identify opportunities for optimization, resulting in improved efficiency and reduced costs. Improved safety: By automating processes, SCADA systems help reduce the risk of accidents and improve overall safety in the business environment. Improved decision-making: A SCADA system provides real-time data, allowing managers and operators to make informed decisions based on accurate information. Remote monitoring and control: A SCADA system can be accessed remotely, providing the ability to monitor and control processes from a central location, regardless of physical location.

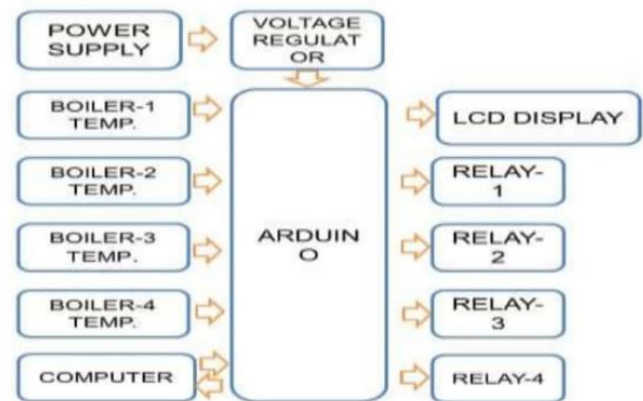

Block Diagram: SCADA System

3.WORKING

SCADA (Supervisory Control and Data Acquisition) is a type of business management software that allows businesses to monitor and control various business processes. Copy to a remote machine. It is widely used in industries such as oil and gas, water and waste, power generation and manufacturing. A SCADA system collects data from sensors and control devices in remote locations and transmits the data to a central control room for monitoring and analysis. It allows operators to monitor and control processes and systems, and can be used to perform various tasks. SCADA systems usually consist of several components, including human-machine interfaces (HMIs), logic controllers (PLCs), remote control units (RTUs),

and communication networks. These units work together to collect data, provide control and transmit information between the control unit and remote locations. In recent years, SCADA systems have become increasingly complex, integrating advanced technologies such as cloud computing, artificial intelligence, and the Internet of Things (IoT).

The working of a SCADA system involves the following steps:

1. **Data Acquisition:** The SCADA system gathers data from various field devices, such as sensors, actuators, and PLCs (Programmable Logic Controllers), using protocols like Modbus, DNP3, or OPC.
2. **Data Processing:** The collected data is processed, analyzed, and stored in a central database for further use.
3. **Monitoring:** The SCADA system provides a graphical interface for monitoring the status of the processes and the field devices. The interface displays real-time information about the process parameters, alarms, and trends.
4. **Control:** The SCADA system allows operators to control the processes remotely by sending commands to the field devices. The commands are executed by the field devices and the process parameters are adjusted accordingly.
5. **Reporting:** The SCADA system generates various reports and provides historical data analysis, which helps in decision making and process optimization.
6. **Alarm Management:** The SCADA system provides an alarm management system that alerts the operators about any abnormal conditions or deviations in the processes. The operators can then take corrective actions to minimize downtime and prevent losses.

4. FUTURE SCOPE:

The future scope of SCADA (Supervisory Control and Data Acquisition) systems is very promising due to the increasing demand for smart and efficient industrial control systems. The future of SCADA systems is expected to be impacted by the integration of new technologies such as Internet of Things (IoT), cloud computing, machine learning, and artificial intelligence.

5. CONCLUSION:

To monitor the load status and temperature in a remote plant, we created an example of a wireless SCADA system. This system uses remote plant data collection technology, which is connected to a PC to monitor parameters of remote plant and transformer load conditions. Using a (programming language) environment platform, we have successfully tested a low-cost SCADA implementation that can be installed and implemented in small-scale running units and SCADA interfaces to monitor and control the entire plant process. Monitor the entire plant process. The findings of this study can be used to build SCADA to monitor and control the entire industry for both commercial and educational purposes. The user interface can be made more user-friendly so that it can be operated from the webpage directly by using the selector switches and input data, and SMS alerts can be delivered to system administrators of any essential notifications for a more facilitated and enlarged service.

REFERENCES

- [1] K.A Akpado "Design, Modeling and Simulation of a Microcontroller Based Temperature Control in a Ventilation System" International Journal of Advanced Research in Electrical, Electronics and Instrumentation Engineering Vol. 2, Issue 7, July 2013
- [2] Purnima "ZIGBEE AND GSM BASED PATIENT HEALTH MONITORING SYSTEM" International Journal of Advanced Research in Electrical, Electronics and Instrumentation Engineering Vol. 3, Issue 1, January 2014
- [3] Hildick-Smith, Andrew, "Security for Critical Infrastructure SCADA Systems," (SANS Reading Room, GSEC Practical Assignment, Version 1.4c, Option 1, February 2005
- [4] A. Dhivya, J. Infanta, K. Chakrapani "Automated agricultural process using PLC and Zigbee", Journal of Artificial Intelligence, ISSN:1994-5450, pp.1-8, 2012
- [5] Bhavneet Sidhu, Hardeep Singh, and Amit Chhabra. "Emerging Wireless Standards - WiFi, ZigBee and WiMAX", World Academy of Science, Engineering and Technology 25, 2007.
- [6] L. Zheng, "ZigBee wireless sensor network in industrial Applications," SICE-ICASE International Joint Conference, pp. 1067-1070, October 2006.
- [7] ZigBee Alliance, Network Specification, Version 2.0, Dec. 2006.
- [8] L. O. Aghenta and M. T. Iqbal, "Low-Cost, Open Source IoT-Based SCADA System Design Using Thingier. IO and ESP3 Thingier," Electronics, vol. 8, no. 8, p. 822, 2019
- [9] GT Heng. Microcomputer-based remote terminal unit for a scada system. Microprocessors and Microsystems, 20(1):39-45, 1996.