

# Solar power Fertilizer Dispensing and pesticide sprayer system

Jadhav Mamta Balkrushna<sup>1</sup>, Salunke Ankita Santosh<sup>2</sup>, Jadhav Aashka Shailendra<sup>3</sup>, Bhongle Samiksha Anil<sup>4</sup>, Nikam N. B.<sup>5</sup>

<sup>1,2,3,4</sup> Student, Department of Electronics and telecommunication Engineering, Institute of Engineering and Technology, Kannad, Maharashtra, India,

<sup>5</sup> Professor, Department of Electronics and telecommunication Engineering, Institute of Engineering and Technology, Kannad, Maharashtra, India,

## Abstract

In order to promote sustainable farming, this paper describes a solar-powered pesticide and fertilizer spraying system. The system reduces reliance on fuel and outside electricity by using solar energy to power the pesticide sprayer and fertilizer dispenser. Lightweight dispensing and spraying equipment appropriate for small and medium-sized farms is powered by a battery that is charged by the solar panel. The system helps farmers accomplish two important agricultural tasks more effectively by combining pesticide spraying at the front and fertilizer application at the back. It seeks to lower operating costs, save time, lessen manual labor, and encourage environmentally friendly farming methods. An overview of the system's concept, design, and anticipated advantages for contemporary farming is given in this study. Keywords: solar energy, pesticide spraying, fertilizer dispensing, solar-powered systems, agricultural automation, eco-friendly farming, renewable energy in farming, dual-purpose sprayer systems, smart farming, and sustainable agriculture.

## Introduction

One of the most crucial industries for producing food is agriculture, but farmers frequently deal with issues like growing fuel prices, a lack of electricity in rural areas, and the requirement for effective crop management. The labor-intensive and time-consuming nature of traditional fertilizer and pesticide spraying techniques can lower productivity and raise labor costs. The use of

automated systems and renewable energy in agriculture is becoming more crucial to overcoming these obstacles.

A clean, affordable, and dependable solution for contemporary agriculture is provided by a solar-powered fertilizer dispensing and pesticide spraying system. The system is appropriate even in remote locations with limited electricity because solar energy offers a consistent and environmentally friendly power source. Farmers can more effectively complete two crucial tasks by integrating pesticide spraying and fertilizer dispensing into a single unit. Additionally, this ensures better crop health, increases accuracy, and minimizes chemical waste.

The idea of a dual-purpose solar-powered system intended to assist small and medium-sized farmers is presented in this paper. The system seeks to lower operating costs, save time, minimize human labor, and encourage sustainable farming methods. An outline of the necessity of this technology is given in the introduction, which also emphasizes how renewable energy can boost agricultural output.

## Hardware Requirement :

- Solar Panel
- Battery Charger
- Controller (Arduino Mega)
- Solar Charge Controller (PWM 10A)
- Bluetooth module
- Buck Converter (5V, 0.5A)
- Relay Driver Board (12V, 0.5A)
- L298N Motor Drivers

- DC Gear Motor (Driving Motor) (12V, 4A)
- DC Pump (Pesticide Sprayer Pump) (12V, 3A)
- Seed/Fertilizer Dispensing Mechanism with Motor (servo motor)
- Frame / Chassis
- Pipes, Nozzles, and Supporting Hardware
- Wheel (Metal Lug Wheel)
- **Total Hardware cost – 7000**

**Block Diagram :**

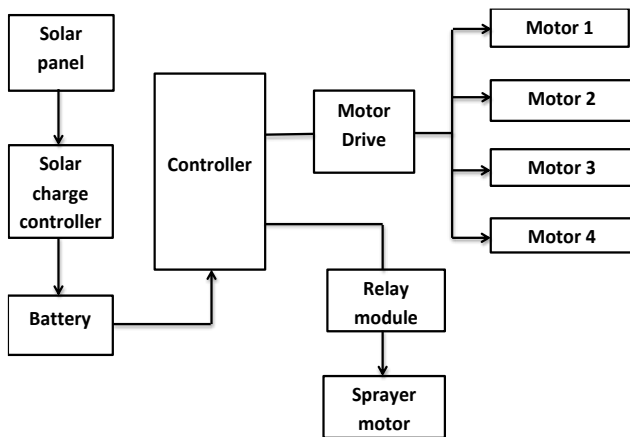

**Working Principle :**

The system uses solar energy to run several motors and a pesticide and fertilizer sprayer.

1. A solar panel

Sunlight is transformed into electrical energy (DC power) by the solar panel.

2. Controller for Solar Charge

The solar charge controller receives the electricity generated by the solar panel.

Its duties include controlling the voltage and current.

Prevent deep discharge or overcharging of the battery.

3. The battery

The electrical energy produced by the solar panel is stored in the battery.

Even in situations where there is little or no sunlight, the system is powered by this stored energy.

4. Controller (Control Unit/Microcontroller)

The battery provides power to the controller.

It serves as the system's brain and:

accepts user input (button or mobile control)

chooses which sprayer or motor to turn on or off.

provides the relay modules with control signals.

5. Relay Components

Relays function similarly to electrically operated switches.

The relay switches the motors' power supply on or off in response to a signal from the controller.

Low-power signals are used to safely control high-power devices.

6. Motors (from Motor 1 to Motor 4)

These motors are useful for:

The vehicle's motion

Mechanism for dispensing fertilizer

Relay control allows each motor to run independently.

7. Motor for Sprayers

A different relay module controls the sprayer motor.

It pumps pesticide or fertilizer through the sprayer nozzle when it is turned on.

Low-power signals are used to safely control high-power devices.

### The system operates in multiple steps:

#### Step 1: Generation of Solar Power

- The solar panel generates DC electricity by absorbing sunlight.
- The battery receives this power from the charge controller.

Step 2: Power Storage • The battery stores energy so that the system can function even at night or in cloudy conditions.

Step 3: System Control: All motors, pumps, and sensors are controlled by the Arduino Mega, which gets power from the buck converter.

#### Step 4: Steering and Driving

- The machine is propelled forward by the hub motor.
- For steering, the winder motor modifies the direction of the wheels.

#### Step 5: Applying Fertilizer

- The fertilizer screw mechanism is rotated by a motor.
- Fertilizer is applied uniformly throughout the field.

#### Step 6: Applying Pesticides

- The pesticide liquid is extracted from the tank by the pump.
- It creates a fine mist by spraying the liquid through nozzles.

#### Step 7: Monitoring the Moisture Sensor

- The moisture sensor determines how wet the soil is.

- If automation is used, fertilizer flow can be adjusted based on the reading.

### Small Points from the Literature Review

#### 1. The System's necessity

Farmers deal with high fuel prices and a labor shortage.

For a good yield, chemical application needs to be consistent.

Dependency on gasoline and diesel sprayers is decreased by solar power.

#### 2. Solar Energy Utilization (Study Results)

DC pumps can be efficiently powered by solar panels during the day.

Constant spray pressure is maintained with the aid of a battery and charge controller.

#### 3. Research on Fertilizer Dispensing

Auger/roller mechanisms are used in the dispensing of granular fertilizer.

Particle size and speed affect flow rate.

Research indicates that motorized metering units increase accuracy.

#### 4. Research on Pesticide Spraying

With the appropriate nozzles, solar sprayers produce consistent spray patterns.

For improved pressure stability, diaphragm pumps are recommended.

The effectiveness of pest control is increased by uniform droplet size.

## Background Study: A Few Details

### 1. Fundamentals of Solar Energy

uses photovoltaic panels to convert sunlight into DC electricity.

Battery health is maintained by the charge controller.

Pumps and motors are powered by stored energy.

### 2. Fundamentals of Pumping and Spraying

The necessary pressure for spraying is produced by DC pumps.

Droplet size and coverage are determined by nozzles.

When spraying pesticides, filters prevent clogging.

### 3. Fundamentals of Fertilizer Dispensing

Controlled metering is necessary for solid fertilizer.

Common mechanisms include fluted rollers, rotary discs, and augers.

For uniform application, flow rate and forward speed must be equal.

### 4. Fundamentals of Control Systems

Motor speed, pump switching, and sensor input are all managed by microcontrollers.

Constant output is guaranteed by flow sensors.

Uniform application per meter is ensured by GPS/encoder.

## Circuit Diagram :

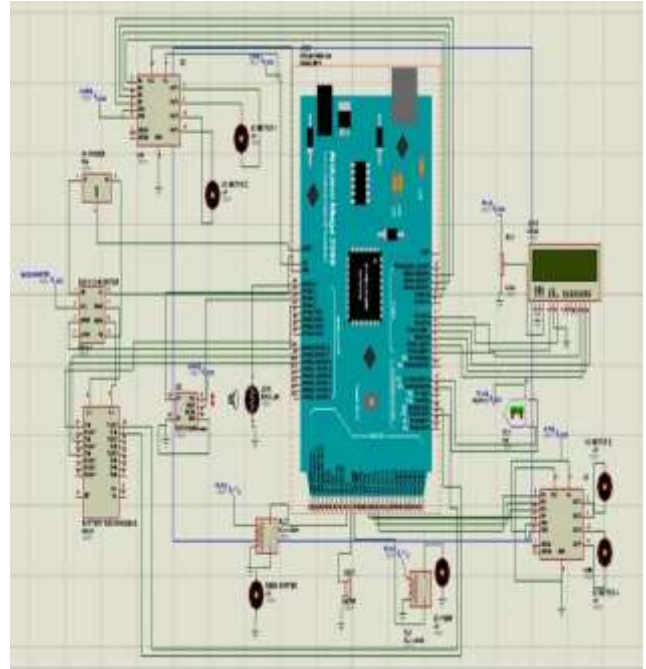

## Working Principle:

Using solar and battery power, this circuit uses an Arduino Mega 2560 to control a sprayer system and several DC motors.

### 1. Power Source

A battery, which is powered by a solar panel via a charge controller, powers the system.

The battery voltage is lowered by a buck converter to the safe level (5V/12V) needed by the Arduino and other parts.

### 2. The Arduino Mega 2560 Controller

The Arduino serves as the system's primary control unit.

It: Gets commands to operate a button, switch, or wireless module.

handles the logic of the program.

transmits control signals to relay modules and motor driver integrated circuits.

### 3. ICs for motor drivers (L293D/L298 type)

Since Arduino pins cannot directly drive motors, motor driver integrated circuits are utilized.

These ICs: Get Arduino control signals.

Increase the current

Control DC motor direction and ON/OFF.

### 4. DC Motors (Motors 1 through 4)

Motor drivers are used to connect four DC motors.

They serve the following purposes:

Movement of vehicles

Mechanism for dispensing fertilizer

The Arduino provides commands that drive motors.

### 5. Module for Relays

The sprayer motor or pump is controlled by a relay.

When the relay is turned on by Arduino:

The sprayer motor is turned on.

Fertilizer or pesticide is sprayed

### 6. LCD Screen

The LCD displays system status, including:

ON/OFF motor

System messages regarding sprayer status

### 7. Buzzer

When the system is operating or is active, the buzzer sounds an alert.

Component	Quantity	Cost (₹)
Solar Panel	1	1500
Battery	1	1200
Arduino Uno	1	375
Bluetooth Module	1	250
L298N	3	360

### Component Quantity Cost (₹)

DC Motors	6	1020
Motor	1	170
Pump	1	800
Wheel	6	300
Jump Wier	40	200
Miscellaneous	-	500

Total Cost ≈ ₹ 6775

### How does the system that dispenses fertilizer and sprays pesticides work?

Two primary farming tasks are carried out by a single machine in the combined system:

Dispensing fertilizer and seeds

Spraying pesticides

A window winder motor is used for steering and a DC hub motor is used for driving the machine on the field. A remote controller allows the farmer to regulate the movement.

A dispensing wheel is rotated by a DC motor to dispense fertilizer. There are several slots on this wheel. Fertilizer or seeds are periodically dropped into the soil from the hopper as it rotates.

Liquid pesticide is drawn from a small tank and forced into pipes and nozzles by a 12V DC pump. The pesticide is evenly sprayed on the plants by these nozzles. This eliminates the need for manual spraying, which exposes farmers to hazardous chemicals.

The entire system is managed by an Arduino Mega. Relays and an L293D motor driver are used to turn the pump or dispensing motor on and off after receiving inputs from the moisture sensor and remote control signals.

Because the farmer does not require two separate machines, the combined design saves money, time, and labor.

### What are the main benefits and effects on farmers of this combined system?

For farmers, this combined system offers numerous significant benefits. Time and labor savings are the main advantages. One machine is used for both fertilizer and spraying, as opposed to separate machines. Farming becomes more productive as a result.

The system has very low operating costs because it is solar-powered. The farmer doesn't require electricity or fuel like gasoline or diesel. Over time, this results in significant financial savings.

Additionally, the system enhances the accuracy and quality of the work. The proper rate of fertilizer dispensing minimizes waste. Pest control is improved by evenly spraying pesticides. The overall crop yield may rise as a result.

Farmers can use the machine safely, especially when spraying pesticides. Farmers don't have to carry bulky sprayers or breathe in dangerous chemicals. This safeguards their well-being.

In general, the system offers:

Cheaper price

Increased output

Reduced exertion

More precise farming

Improved crop quality

As a result, both large-scale and small-scale farmers benefit greatly from the system.

### **Conclusion :**

In conclusion, the Solar Powered Fertilizer Dispensing and Pesticide Spraying System is a practical and beneficial agricultural project. It is intended to lessen farmers' labor-intensive tasks and speed up and simplify farming operations. The system operates without fuel or electricity thanks to solar energy, which is very beneficial in rural areas. The pesticide spraying unit correctly applies

chemicals to crops, while the fertilizer dispensing unit evenly distributes fertilizer on the soil. This increases crop growth and lowers pesticide and fertilizer waste.

### **Conclusion (Points)**

Additionally, by shielding farmers from direct exposure to dangerous chemicals, the system enhances their health and safety. Utilizing renewable solar energy lowers pollution and makes the system more environmentally friendly. Even small and medium-sized farmers can easily use it because of its straightforward, inexpensive, and simple design. The system increases agricultural productivity while saving money, time, and labor. All things considered, this project demonstrates how basic automation and solar energy can enhance conventional farming practices. It promotes the use of clean energy in agriculture and sustainable agriculture.

1. Requires neither fuel nor electricity because it uses solar energy.
2. Saves farmers time and lessens manual labor.
3. Offers efficient pesticide spraying and consistent fertilizer dispensing.
4. Prevents farmers from being directly exposed to chemicals.
5. An inexpensive and simple system to use.
6. Eco-friendly and lessens pollution in the environment.
7. Fit for small and medium-sized farms.
8. Aids in raising crop efficiency and productivity.
9. Is able to function even in places without electricity.
10. Encourages intelligent and sustainable farming.

## RESULT & OUTPUT

The developed Solar Power Fertilizer Dispensing and Pesticide Sprayer System was successfully designed, simulated, and implemented. The system operated efficiently using solar energy as the primary power source. The solar panel was able to charge the battery properly, and the buck converter provided a stable voltage supply to the Arduino and other components.

During testing, the DC motors worked as expected, allowing smooth movement of the system in different directions. The motor driver IC controlled the motors effectively based on the programmed instructions. The relay module successfully controlled the ON/OFF operation of the pump, and the pump was able to spray fertilizers and pesticides uniformly.

The system demonstrated proper coordination between all components, including power supply, control unit, and output devices. The spraying mechanism worked efficiently, covering the required area with consistent output. The buzzer also provided proper indication during operation.

Overall, the project achieved its objective of automating fertilizer dispensing and pesticide spraying using solar energy. The system proved to be reliable, efficient, and suitable for agricultural applications, reducing manual effort and improving productivity.



## Reference :

- UG Students, Jhulelal Institute of Technology, Nagpur, India (2022) Solar Powered Multifunction Pesticide Sprayer, International Journal for Research in Engineering Application & Management (IJREAM) [https://www.researchgate.net/publication/362013227\\_Solar\\_Powered\\_Multifunction\\_Pesticides\\_Sprayer](https://www.researchgate.net/publication/362013227_Solar_Powered_Multifunction_Pesticides_Sprayer)
- Smart Solar Powered Agricultural Fertilizer Sprayer by Srinivasan Mallan, K. Karthick, B. Cheran, and S. Karthickram Bannari Amman Institute of Technology, Sathyamangalam (2021) [https://www.researchgate.net/publication/349933452\\_Smart\\_Solar\\_Powered\\_Agricultural\\_Fertilizer\\_Sprayer](https://www.researchgate.net/publication/349933452_Smart_Solar_Powered_Agricultural_Fertilizer_Sprayer)
- Design of Solar Hybrid Pesticide Spray System, Surrender Kumar (2024), International Journal of Technical Research & Science, [https://www.ijtrs.com/uploaded\\_paper/DESIGN%20OF%20SOLAR%20HYBRID%20PESTICIDE%20SPRAY%20SYSTEM.pdf](https://www.ijtrs.com/uploaded_paper/DESIGN%20OF%20SOLAR%20HYBRID%20PESTICIDE%20SPRAY%20SYSTEM.pdf)
- Kumawat Mukesh M, Dipak Wadavane, Naik Ankit, Vidhate Dipak, Ghuge Chandrakant, BE student (2018) Solar-powered pesticide sprayer for agricultural use: <https://www.irjet.net/archives/V5/i5/IRJET-V5I5646.pdf>