

# THREE PHASE VOLTAGE AND CURRENT FLUCTUATION RECORDER WITH SINGLE DISPLAY USING MICROCONTROLLER

1. Mr.S.SARATHKUMAR, PG STUDENT

Dr Kalaingar Karunanithi Institute of Technology

2. Mr.R.DHAKSHINESH, 3.Mr.R.JAI RAHUL, 4.Mr.M.LAKSHAN SUGAN,

5. Mr.T.RANJITHKUMAR, 6.Mr.S.RAJESH

Final Year Students Nanjiah Lingammal Polytechnic College, Coimbatore.

**Abstract** -The quality of power supplied is affected by various internal and external factors of the power system. The presence of harmonics, voltage and frequency variations deteriorate the performance of the system. In this paper the frequently occurring power quality problem- voltage variation is discussed. The voltage sag/dip is the most frequently occurring problem. There are many methods to overcome this problem. Among them the use of FACT devices is an efficient one. This paper presents an overview of the FACT devices like- DVR, D-STATCOM, and Auto-Transformer in mitigating voltage sag. All kinds of input parameters will be first converted into voltage level by using proper transducers. Then these voltages are given to the analog input pin of micro controller circuit ATMEGA-16. The port lines are connected to the LCD display. The set pot and key input are connected to the micro controller. The microcontroller senses the voltage level and current level and counts the no of fluctuation status. If enter recall key we can see the no of fluctuations status. Here we develop the circuit with easily available ICs, the operation and installation of our unit is not a risky one. We can easily provide the unit in Main panel Board.

**Key Words:** 3 Phase Power, FACTS, DVR, Current, Voltage Measurement, ATMEGA-16

## 1. INTRODUCTION

Electrical energy is the most efficient and popular form of energy and the modern society is heavily dependent on the electric supply. The life cannot be imagined without the supply of electricity. At the same time the quality and continuity of the electric power supplied is also very important for the efficient functioning of the end user equipment. Most of the commercial and industrial loads demand high quality uninterrupted power. Thus, maintaining the qualitative power is of utmost important. The quality of the power is affected if there is any deviation in the voltage and frequency values at which the power is being supplied. This affects the performance and life time of the end user equipment. Whereas, the continuity of the power supplied is affected by the faults which occur in the power system. So, to maintain the continuity of the power being supplied, the faults should be cleared at a faster rate and for this the power system switchgear should be designed to operate without any time lag. The power quality is affected many problems which occur in transmission system and distribution system. Some of them are like-harmonics, transients, sudden switching operations, voltage fluctuations, frequency variations etc. These problems are also responsible in deteriorating the consumer appliances. In order to enhance the behaviour of the power system, these all problems should be eliminated.

## 2. OBJECTIVE

The objectives of this paper are:

- To investigate the techniques to mitigate voltage sag, swell
- To study and analyse the behaviour of FACT devices in reducing the voltage unbalance
- To select a device that best suits the application
- To control the device such that desired performance is obtained

## 3. PROBLEM STATEMENT

The electrical energy is one of the easily used forms of energy. It can be easily converted to other forms of energy. With the advancement of technology, the dependency on the electrical energy has been increased greatly. Computer and telecommunication networks, railway network banking, post office, life support system is few applications that just cannot function without electricity. At the same time these applications demand qualitative energy. However, the quality of power supplied is affected by various internal and external factors of the power system. The presence of harmonics, voltage and frequency variations deteriorate the performance of the system.

Voltage sag is defined as a sudden reduction in supply voltage to between 90% and 10% of the nominal value, followed by a recovery after a short interval. The standard duration of sag is between 10 milliseconds and 1 minute. Voltage sag can cause loss in production in automated processes since voltage sag can trip a motor or cause its controller to malfunction. Voltage swell is defined as sudden increase in supply between 110% and 180% of the nominal value of the duration of 10 milliseconds to 1 minute. Switching off a large inductive load or energizing a large capacitor bank is a typical system event that causes swell.

Voltage sag/swell is most important power quality problems challenging the utility industry can be compensated and power is injected into the distribution system. By injecting voltage with a phase advance with respect to the sustained source-side voltage, reactive power can be utilized to help voltage restoration. Dynamic Voltage Restorer, which consists of a set of series and shunt converters connected back-to-back, three series transformers, and a dc capacitor installed on the common dc link.

## 4. PROPOSED METHODOLOGY

In this paper the frequently occurring power quality problem- voltage variation is discussed. The voltage sag/dip is the most frequently occurring problem. There are many methods to overcome this problem. Among them the use of FACT devices is an efficient one.

## 5. BLOCK DIAGRAM

The microcontroller based three phase voltage and current calculator for the transmission system is shown in above diagram fig 5.1.

The paper consists of the following block.

- a) Microcontroller
- b) LCD display unit
- c) Load driver relay
- d) Comparator
- e) Power supply section

### Power Supply

230-volt single phase supply is used for power source of the blocks

### Step Down Transformer

Transformer is a static device transfer the power without change the frequency of the supply. Here we use step down transformer convert the 230 volts into 12volt AC.

### Rectifier & Filter

The step downed voltage is fed as to the bridge rectifier for convert in to DC voltage and fed to filter for reduce the ripples of the AC.

### Regulator

Regulators used to regulate the output voltage from the rectifier and maintain the constant output voltage to the microcontroller.

### Comparator

The device used to compare the original value of voltage and current with reference value predefined by the consumer and give the error signal to the microcontroller which trigger the converter to increase the voltage level and vice versa.

### 3-Phase Voltage Measurement Circuit

In this block consists of potential Tran's former, potential divider circuit and voltage follower circuit. Here we are using op-amp 741 based voltage follower circuit. This output is connected to the microcontroller.

### 3- Phase Current Measurement Circuit

In this circuit consists of 10:0.1 ratio current transformers, IC 741 based precision rectifier circuit. The current sensor is used current transformer. The sensor output is going to current measurement circuit. This output is connected to the microcontroller.

### LCD Display

LCD display is interfaced with the micro controller to display the real value of power system and display the messages like no of power fluctuation status.

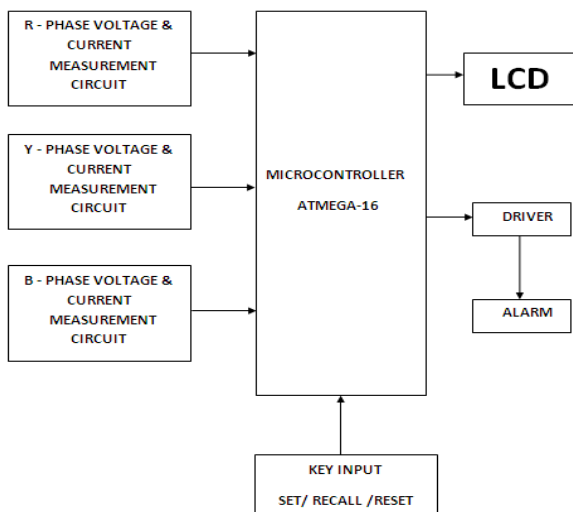

Fig 5.1 Block diagram of three phase scanner

### Control Algorithm

- Step 1:** Start the program.
- Step 2:** Initialize the Port C and Port B of microcontroller.
- Step 3:** Initialize LCD connected to Port D.
- Step 4:** Clear the LCD display.
- Step 5:** Display the "WELCOME".
- Step 6:** Check whether voltage sag problem occurred or not
- Step 7:** If "yes", go to next Step, otherwise go to Step 11.
- Step 8:** Microcontroller passes signals to Relay, Comparator and activates DVR Circuit
- Step 9:** Repeat Step 3 and Step 4.
- Step 10:** Display "VOLTAGE SAG OCCURS" and "VOLTAGE TO BE ADDED"
- Step 11:** Check whether the voltage is in Normal condition or not.
- Step 12:** If "yes", go to next step, otherwise go to Step 14.
- Step 13:** Repeat Step 3 & Step 4 and display "NORMAL STATE".
- Step 14:** Check whether the voltage is above the Normal level.
- Step 15:** If "yes", go to next Step, otherwise go to Step 6.
- Step 16:** Repeat Step 3 & Step 4 and display "LOAD REMOVED".

### 6. POWER MODULE

In the DVRs that employ ac/dc/ac conversion, it is required to use a large capacitor in the dc link to smooth the dc link voltage. Hereafter these topologies are called conventional DVRs. A considerable amount of technical works has been done on the conventional DVRs concerning both hardware circuit topology, control strategy and voltage disturbances detection methods. The topologies of DVRs vary from both viewpoints of how to connect to the system and the used inverter topology in the DVR structure. The DVRs can operate in both low voltage and medium voltage distribution systems Application of multilevel inverters in the conventional DVRs has been presented as a solution to handle high voltage and high power by the DVRs Beside the voltage sag and swell compensation, the DVR has been successfully used for voltage harmonic compensation and downstream fault current limitation.

#### 6.1 Current Measurements

This circuit around the first half formed as a half wave rectifier. That produces an inverted half wave replica of the input signal. For negative input signal at R1 output is positive. Figure 3.1 shows the circuit diagram of full wave precision rectifier. Forward biasing D1 and closing the negative feedback through R2. This produces an inverted gain of almost exactly one, since R1 and R2 are closely matched for positive input signals, the amplifier output is negative and D1 is off – D2 is on in this case, applying feed back to the summing point and clamping the op amp output to -0.6v this clamped output swing aids in minimizing response time, because it prevents amplifier saturation. Output from this inverting rectifier is added to the original input signal in next stage op amp (summing mixture), with the signal amplitude and phase relations. Negative attenuations of Ein results in no output at E1, due to the rectification. Ein feeds A2 through 200K ohms resistance, and E1 feeds A2 through a 100K ohms resistor. The net effect of this scaling is that, for equal amplitude of Ein and E1, E1 provide twice as much current from the running point. This fact is used to advantage here as the negative alteration of E1 produces twice the input current of that could by the positive alteration of Ein.

The output from the summing amplifier is given to the inverting amplifier with unity

$$\text{gain. Output} = \frac{-r_f}{r_1} \times V_{in}$$

Rf = feedback resistance = 10 K

RI = Input resistance = 10 K

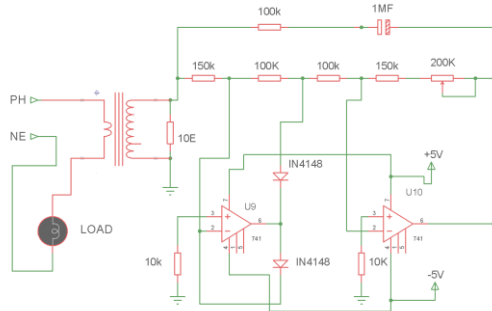

Fig 6.1 Current Measurement

### 6.2 Voltage Measurements

Potential transformers are used to operate voltmeters, the potential coils of watt meters and relays from high voltage lines. The primary winding of the transformer is connected across the line carrying the voltage to be measured and the voltage circuit is connected across the secondary winding.

The design of a potential transformer is quite similar to that of a power transformer but the loading of a potential transformer is always small, sometimes only a few voltage amperes. The secondary winding is designed so that a voltage of 9 to 12V is delivered to the instrument load. The normal secondary voltage rating is 12V.

Various types of potential transformer in higher voltages are,

1. Insulating casing PT
2. Moulded rubber PT
3. Cascaded transformer
4. Capacitive voltage transformer
5. Burden of an Instrument Transformer

It is convenient to express load across the secondary winding terminals as the output in voltage-ampere at the rated secondary winding voltage. The rated burden is the voltage ampere loading which is permissible without errors exceeding the limits for the particular class of array.

$$\text{Burden rating} = I_2^2 * Z_2^2 \text{ or } I_3^2 * Z_3^2$$

### Voltage Measurement Circuit

In this circuit consists of potential Trans former, rectifier potential divider circuit and voltage follower circuit. Here we are using opamp 741 based voltage follower circuit... This output is connected to the microcontroller.

The input line voltages fed to the 230v/12v step down transformer, the transformer reduce the input voltage. The secondary of the transformer is connected to the rectifier circuit. With filter.

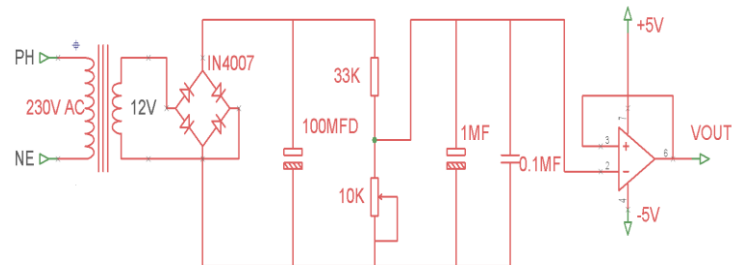

Fig 6.2 Voltage Measurements

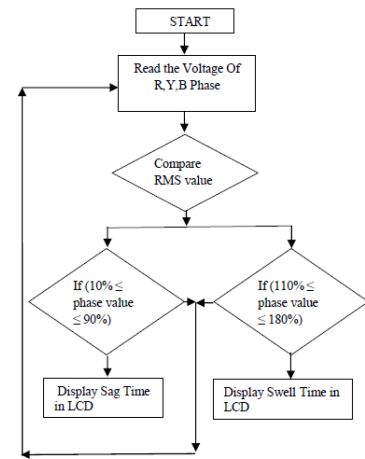

Fig 6.3 Flow Chart for R,Y, B PHASE Scanner

The rectified dc voltage reduces the 2.3v and connects to the IC 741 based analog buffer circuit. The analog buffer is nothing but a unity gain amplifier. It is maintained impedance matching and current driving process. In this circuit output is connected to the microcontroller circuit.

### 6.3 Power Module Explanation

The mains voltage AC 230V is Step Down to 9 Volt, using 9V Step down transformer. The low value secondary voltage is fed to the rectifier is formed using four no. of IN 4007. For first half cycle, Diodes D1 & D2 come to action and next half cycle diode D3 & D4 come to action, finally unidirectional dc supply is fed to the filter capacitor.

The charging & discharging property of capacitor provide pure smooth dc is nearly peak value of the secondary voltage. The pure DC supply is fed to regulator IC's input terminal. Due to the regulator action, finally, regulated 5 volts is available at output terminals. In this circuit we used the three potential transformer and current transformer for

measuring voltage and current and the sensed voltage and current fed as to the comparators.

Potential transformer output is fed as to the voltage measurements comparator and current transformer output fed to precision rectifier to measure the current and voltage for each phase if any changes in any phase, the comparator give the signal to the microcontroller and the microcontroller generate the trigger pulses for thyristor-based DVR to clear the

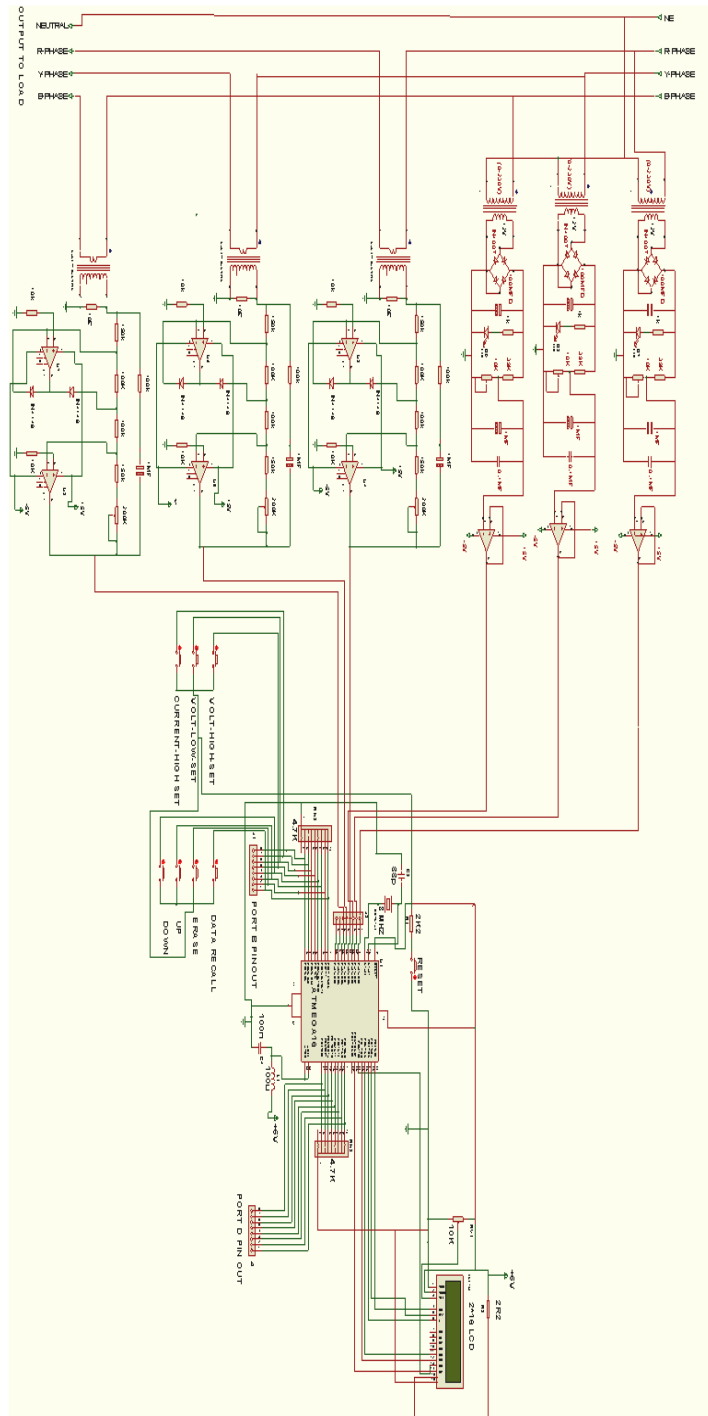

Fig 6.4 Circuit Diagram for R,Y, B 3Phase Scanner

voltage and current. LCD display used to display the sag and swell of voltage and DVR connections.

#### 6.4 Advantages

1. Digital display- very high accuracy.
2. Solid state devices- long life.
3. More number of channels can be added easily.

#### 6.5 Applications

1. All type of power plant and EB stations
2. Transmission and distribution system
3. Distribution transformer.

### 7. CONCLUSION

The demand for electric power is increasing at an exponential rate and at the same time the quality of power delivered became the most prominent issue in the power sector. Thus, to maintain the quality of power the problems affecting the power quality should be treated efficiently. Among the different power quality problems, voltage sag is one of the major one affecting the performance of the end user appliances. In this paper the methods to mitigate the voltage sag are presented. From this paper, the following conclusions are made among the different methods to mitigate the voltage sag, the use of FACT devices is the best method. Our paper successfully prepared and viewed by following.

1. The FACT devices like DVR, D-STATCOM are helpful in overcoming the voltage unbalance problems in power system.
2. DVR is a series connected device and injects voltage to compensate the voltage unbalance.
3. D-STATCOM is a shunt connected device and injects current into the system.
4. These devices are connected to the power network at the point of interest to protect the critical loads.
5. These devices also have other advantages like harmonic reduction, power factor correction.

8. HARD WARE MODULES

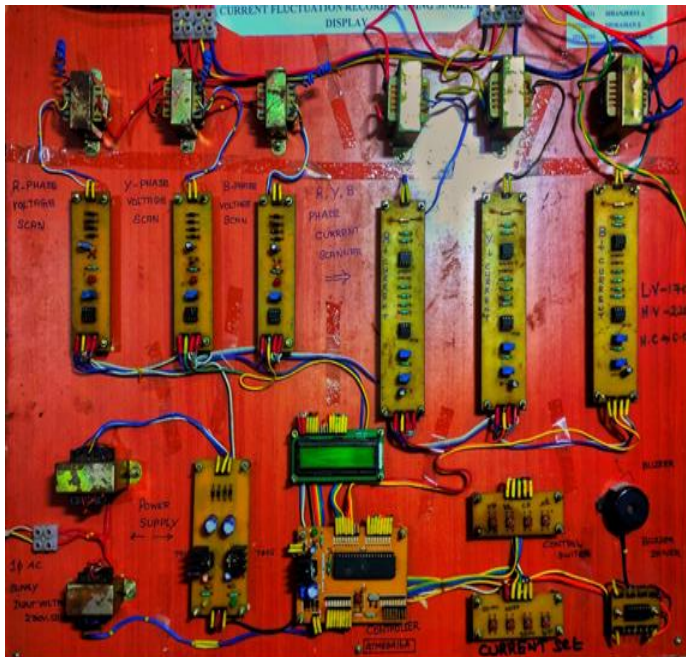

Fig 8.1 Hardware module for R, Y, B 3Phase Scanner

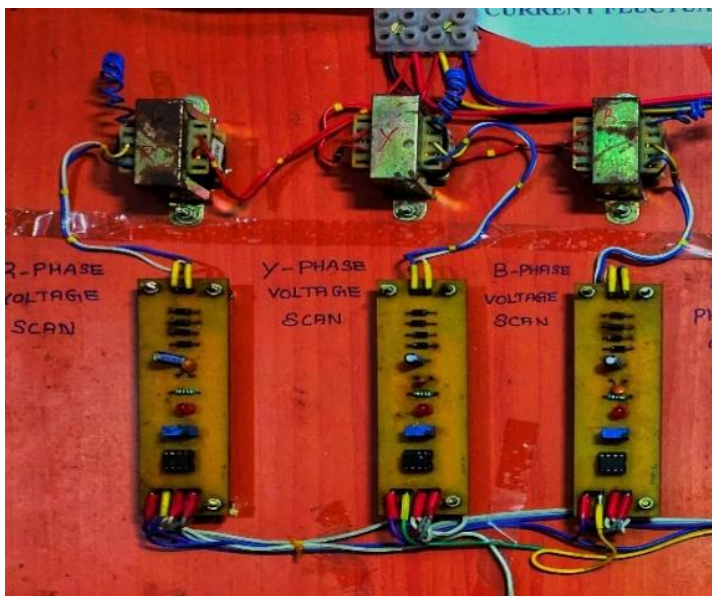

Fig 8.2 Hardware module for R, Y, B Voltage Scanner

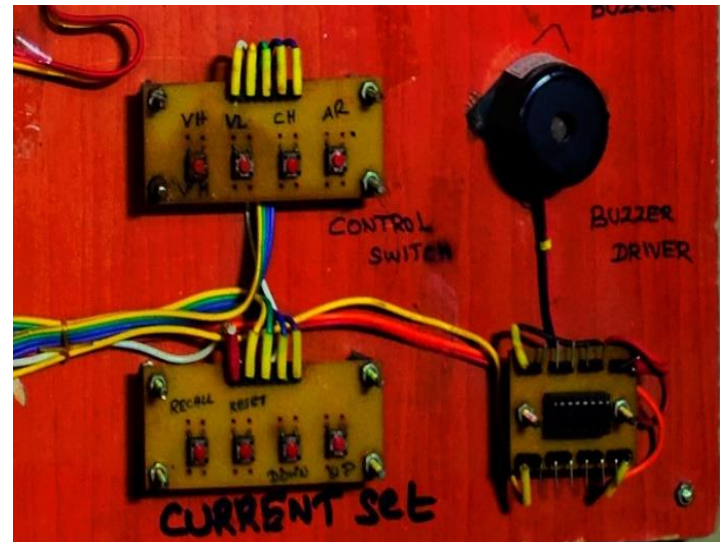

Fig 8.3 Hardware module for Control Unit and Alarm Unit

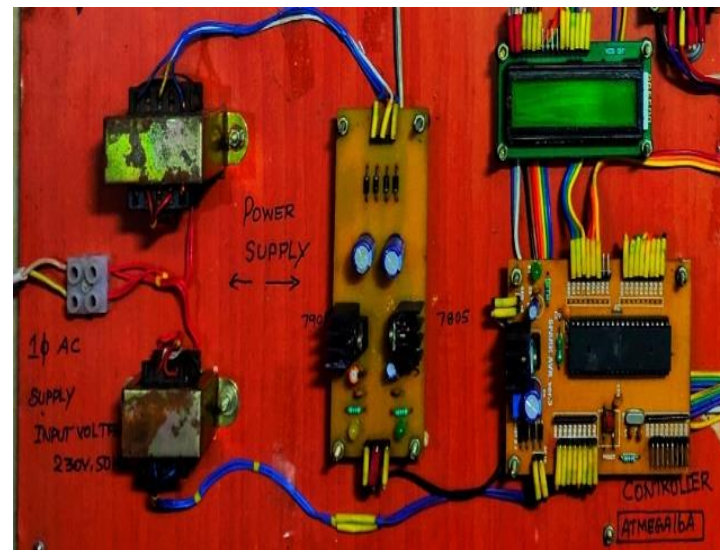

Fig 8.4 Hardware module for Microcontroller, DVR, Display Unit



Fig 8.5 Hardware module for R, Y, B Current Scanner

## 9. REFERENCE

- Kantaria, R. A.; Joshi, S.K.; Siddhapura, K. R., "A novel technique for mitigation of voltage sag/swell by Dynamic Voltage Restorer (DVR)," Electro/Information Technology (EIT), 2010 IEEE International Conference on , vol., no., pp.1,4, 20-ay 2010.
- Kong Shuhong; Yin Zhongdong; Shan Renzhong; Shang Weidong, "A Survey on the Principle and Control of Dynamic Voltage Restorer," Energy and Environment Technology, 2009. ICEET '09. International Conference on , vol.2, no., pp.57,60, 16-18 Oct. 2009.
- Elango, S.; Chandra Sekaran, E., "Mitigation of Voltage Sag by Using Distribution Static Compensator (D-STATCOM)," Process Automation, Control and Computing (PACC), 2011 International Conference on , vol., no., pp.1,6, 20-22 July 2011.

## 10. REFERENCE BOOKS

- KENNETH J. AYALA, 8051 Microcontroller Architecture, Programming and Applications.
- Power System Operation and Control S.Sarathkumar, P.J.Sureshbabu, 2015 ARK Publication Chennai.
- 8051 Microcontroller and Embedded Systems using Assembly and C by Mazidi, Mazidi and D.MacKinlay, 2006 Pearson Education Low Price Edition.
- Microprocessor and Microcontroller by R.Theagarajan, Sci Tech Publication, Chennai.
- Power Electronics and its applications .Sarathkumar, P.J.Sureshbabu, Dec-2015 ARK Publication Chennai.
- Microcontroller S.Sarathkumar, S.Sakthidevi, Feb-2018 ARK Publication Chennai.

## AUTHORS



**SARATHKUMAR S** has received the Bachelor Degree of **Electrical and Electronics Engineering** from **Anna University Chennai with University Gold Medal**. He is a PG scholar in Power System Engineering at **Dr Kalaingar Karunanithi Institute Of Technology Coimbatore**. He is a former Lecturer in Electrical and Electronics Engineering from **Nanjiah Lingammal Polytechnic College Coimbatore**. He is a Member of Research Foundation of India.



**DHAKSHINESH R** is a Final Year Student of Electrical and Electronics Engineering from **Nanjiah Lingammal Polytechnic College, Mettupalayam, Coimbatore, Tamilnadu**.



**JAI RAHUL R** is a Final Year Student of Electrical and Electronics Engineering from **Nanjiah Lingammal Polytechnic College, Mettupalayam, Coimbatore, Tamilnadu**.



**LAKSHAN SUGAN M** is a Final Year Student of Electrical and Electronics Engineering from **Nanjiah Lingammal Polytechnic College, Mettupalayam, Coimbatore, Tamilnadu**.



**RANJITHKUMAR T** is a Final Year Student of Electrical and Electronics Engineering from **Nanjiah Lingammal Polytechnic College, Mettupalayam, Coimbatore, Tamilnadu**.



**RAJESH S** is a Final Year Student of Electrical and Electronics Engineering from **Nanjiah Lingammal Polytechnic College, Mettupalayam, Coimbatore, Tamilnadu**.