

# TRACK SENSING OBSTACLE AVOIDANCE TECHNOLOGY FOR AUTONOMOUS VEHICLE

Y.Jeevan

ECE Department, Guru Nanak Institute of  
Technology,Hyderabad

P.Sandhya

[polepongusandhya1@gmail.com](mailto:polepongusandhya1@gmail.com)

ECE Department, Guru Nanak Institute of  
Technology,Hyderabad

S.Vedanth yadav

[salendravedhanth@gmail.com](mailto:salendravedhanth@gmail.com)

ECE Department, Guru Nanak Institute of  
Technology,Hyderabad

M.Imthiyaz

[imthiyazmolla@gmail.com](mailto:imthiyazmolla@gmail.com)

ECE Department, Guru Nanak Institute of  
Technology,Hyderabad

## ABSTRACT

The developed and tested autonomous robotic vehicle with a track sensing and obstacle avoidance system, using an motor driver and an controller. The vehicle is designed to move autonomously in different environments while detecting obstacles and making avoidance decisions. It is fitted with an HC-S ultrasonic sensor, which continuously measures the distance for the presence of an obstacle and changes the path of the vehicle accordingly. The motor driver L298 controls the two DC motors, which aid in controlling the movement of the robot accurately. The microcontroller then processes this information from the ultrasonic

sensor and instructs the motor driver to make adjustments to achieve a smooth navigation and obstacle avoidance in real-time. Designed for handling various types of terrains and obstacles, the robot showcases very advanced techniques of collision avoidance. The control software is written in the tonny and C++ programming, integrating sensor information with motor commands. This project is for improving efficiency and autonomy in terms of robotic vehicles, with absolutely no manual intervention to the least possible while improving operational reliability.

## INTRODUCTION

Track Sensing Obstacle Avoidance Technology is an essential part of autonomous vehicle systems, enabling vehicles to understand their surroundings, recognize obstacles, and navigate safely. It uses a combination of advanced sensors—LiDAR for high-resolution 3D mapping, RADAR for longrange detection and reliable velocity measurements, cameras for visual understanding of road signs, pedestrians, lanes, and objects, and GPS/IMU units for accurate positioning and orientation. Each sensor provides different strengths, and when fused together through sensor-fusion algorithms such as Kalman filters, deep learning models, and occupancy grid mapping, the vehicle gains a more complete and reliable picture of its environment. This integrated perception system identifies both static and dynamic obstacles, classifies them using AI models, and predicts their motion to determine how they might behave in the near future. Once the environment is understood, intelligent planning algorithms evaluate this information to decide the safest and most efficient action. These decisions may involve slowing down, stopping, changing lanes, or adjusting the route to avoid obstacles while maintaining smooth and stable driving. Path-planning methods like A\*, RRT, and Model Predictive Control help the vehicle generate a safe trajectory, while the control system precisely manages steering, acceleration, and braking to follow that path accurately. Although the system is highly advanced, it continues to

face challenges such as harsh

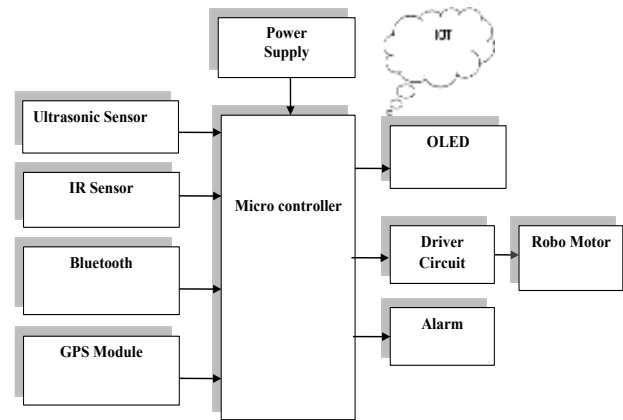

weather, lowlight conditions, unpredictable human or animal behavior, and unusual obstacles. As sensor technology, AI models, and onboard computing power continue to improve, track sensing and obstacle avoidance will become even more reliable, supporting higher levels of autonomy and increasing public trust in self-driving vehicles.

### I. EXISTING SYSTEM

II. Current obstacle avoidance systems in autonomous vehicles mainly rely on cameras, LiDAR, or GPS to detect road edges and obstacles. While these technologies are effective, they can be expensive, sensitive to weather conditions, and may require high processing power. In many basic robotic vehicles or low-cost autonomous systems, simple IR or ultrasonic sensors are used, but they often lack precision and struggle to handle complex or dynamic environments.

### PROPOSED SYSTEM

The proposed system uses a combination of track sensing and obstacle detection technology, such as infrared or ultrasonic sensors, to allow autonomous vehicles to follow a defined path while intelligently avoiding obstacles in real-time. The system

continuously scans the surroundings and adjusts the vehicle's direction to stay on track and prevent collisions. It is a cost-effective and efficient solution suitable for small-scale autonomous vehicles, especially in indoor or controlled environments

## II. METHODOLOGY

The methodology for the Track Sensing and Obstacle Avoidance Technology for Autonomous Vehicle project follows a structured and modular approach in which the system is divided into sensing, processing, and control units. A top-down design method is used to develop individual modules such as track sensing, obstacle detection, and motor control, which are later integrated into a complete system. The track sensing mechanism uses infrared (IR) sensors to detect the path by identifying contrast differences between the track and the surface, allowing the vehicle to continuously adjust its direction and stay aligned. For obstacle detection, an ultrasonic sensor is employed, which works on the principle of Ultrasonic Wave Propagation to measure the distance between the vehicle and any obstacle. The microcontroller acts as the central processing unit, receiving inputs from both IR and ultrasonic sensors and making decisions based on programmed logic, where obstacle avoidance is given higher priority than track following. The motor driver controls the movement of the vehicle by executing actions such as forward motion, turning, stopping, or reversing based on the control signals. The system operates in a continuous loop where sensor data is monitored in real time, and appropriate actions are taken instantly. Finally, the integrated system is tested under different track and obstacle conditions to evaluate performance in terms of accuracy, response time, and stability while considering constraints like sensor limitations, power consumption, and environmental factors.

## Applications

### 1. Surveillance and Security

The robot can be used for remote surveillance in homes, offices, warehouses, and restricted areas. Users can control it via mobile devices and monitor live data, making it useful for security patrols and real-time incident reporting.

### 2. Disaster Response and Rescue

In hazardous environments such as collapsed buildings, fire zones, or chemical spills, the robot can autonomously navigate and be remotely controlled to search for survivors or assess damage without risking human lives.

### 3. Smart Home Automation

The robot can perform tasks such as monitoring different rooms delivering small items, or interacting with smarthome devices, offering convenience and automation in daily household tasks.

### 4 . Agricultural Monitoring

It can be deployed in agricultural fields for monitoring crop health, soil conditions, and environmental parameters. The mobile and autonomous features make it ideal for use in large and uneven terrains.

### 5. Military and Defense Operations

These robots can be used for reconnaissance missions, bomb detection, or remote inspection in combat zones, reducing risk to soldiers while enhancing situational awareness.

### 6. Industrial Automation

In industries, the robot can assist in monitoring equipment, transporting small

components, or inspecting dangerous machinery areas where human access is limited.

## HARDWARE DETAILS

### Power Supply

The power supply is the backbone of the system. It ensures that all components receive the correct voltage and current. Typically, a Li-ion battery or adapter (5V or 9V) is used, with a voltage regulator (like 7805) to step down to 3.3V or 5V, suitable for components like NodeMCU, sensors, and motors. This also includes power distribution to the motor driver, sensors, and NodeMCU.

### Raspberry Pi Pico W

The microcontroller with built-in Wi-Fi. It acts as the central processing unit. It receives data from sensors (e.g., obstacle sensor), processes it, and makes decisions like stopping the motor or sending alerts. It also handles communication—both Bluetooth (via a module) and Wi-Fi (for IoT).

You can program it using Embedded C.

### Bluetooth Module

Typically an HC-05 Bluetooth module is used here. This module allows the robot to be controlled via a mobile application. When the user sends a command ("move forward"), it's received by the NodeMCU through this module, which then triggers motor movement.

### Obstacle Detection Sensor

Commonly IR sensor is used.

The sensor continuously checks for obstacles ahead. If it detects an object within a certain range, it sends a signal to the NodeMCU. NodeMCU then takes action: e.g., stops the robot, activates an alarm, or reroutes the robot.

### OLED Display

Usually a small OLED display is used. It displays real-time data like: Obstacle distance Battery level (if monitored) Robot status (e.g., "Obstacle Ahead", "Moving Forward", "Bluetooth Connected") It's useful for debugging and monitoring without needing to connect to a PC.

### IoT (Internet of Things)

NodeMCU's built-in Wi-Fi allows it to connect to cloud platforms. Popular platforms: ThingSpeak.

Enables:

Remote monitoring (e.g., obstacle logs, movement logs) Remote control via the internet Data logging (e.g., distance sensor data) This can extend the robot's functionality from local (Bluetooth) to global access.

### Alarm

This could be a simple buzzer. It activates under certain conditions like:

Obstacle detection, Unauthorized Bluetooth access System fault (e.g., motor failure) Acts as an auditory feedback for important events.

### Driver Circuit

Most likely a motor driver IC L293D. NodeMCU outputs low-power control signals; this circuit amplifies them to drive high-power motors.

Controls:

Direction (forward, backward) Speed (via PWM) It isolates the motors from the sensitive NodeMCU pins.

### Robo Motor

The motors used are DC geared motors or BO motors. These physically move the robot. They respond to control signals from the driver circuit and perform the movement (left, right, forward, reverse).

## SOFTWARE DETAILS

### Embedded System Software:

The core of the smart mobile controlled autonomous robot lies in its embedded system software, typically programmed using platforms like Arduino IDE, MicroPython, or C++. This software is responsible for interfacing with sensors (such as ultrasonic or IR), controlling motors through PWM signals, and managing

communication modules like Bluetooth (HC-05) or Wi-Fi (ESP32). It includes logic for switching between manual and autonomous modes,

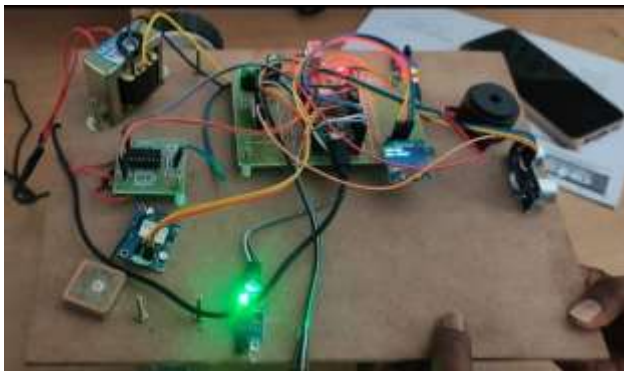

executing obstacle avoidance, line following, or simple navigation algorithms. Real-time data from sensors is processed to enable the robot to respond appropriately to its environment without human intervention.

**Mobile Application and Communication:**

The mobile control interface is developed using tools such as MIT App Inventor, Flutter, or Android Studio, allowing users to control the robot wirelessly through a smartphone. The app typically includes a joystick or button-based interface, a mode selector, and status indicators. Communication between the app and robot is established via Bluetooth or Wi-Fi using serial communication or HTTP protocols. In manual mode, the app sends commands for movement, while in autonomous mode, it can monitor the robot's actions. Advanced setups may include cloud integration for remote control, data logging, or real-time tracking through services like Firebase or MQTT.

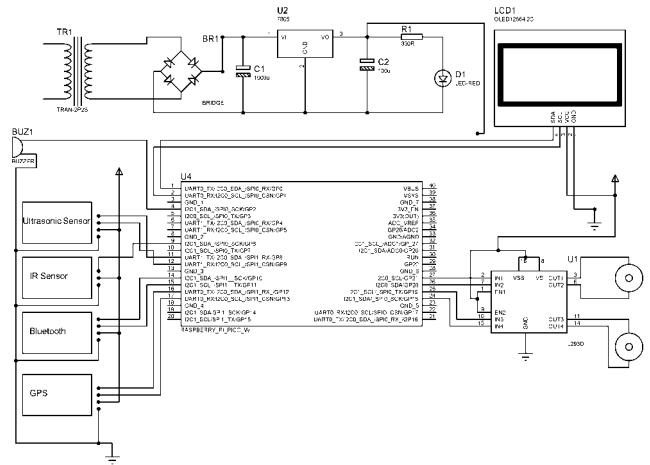

Fig.2 SCHEMATIC DIAGRAM

Fig 3: PROTOTYPE

**CONCLUSION**

The autonomous robotic vehicle developed in this project demonstrates a reliable and efficient solution for real-time navigation and obstacle avoidance without manual intervention. By integrating an L298 motor driver with a microcontroller and HC-SR04 ultrasonic sensor, the system successfully detects and avoids obstacles while navigating along a predefined track. The control logic, implemented using Tonny and C++ programming, ensures accurate and responsive motor control based on continuous sensor feedback.

This project highlights the potential of combining simple, cost-effective components with intelligent programming to create autonomous systems capable of operating in varied environments. The robot's ability to adapt to different terrains and avoid collisions in real-time makes it a practical model for future applications in autonomous transportation, search and rescue missions, and automated delivery systems. Overall, the system contributes to advancing the field of autonomous robotics with a focus on improved efficiency, safety, and self-reliance.

## ACKNOWLEDGEMENT

I would like to express my sincere gratitude to our internal guide, **Mr.Y.Jeevan**, Assistant Professor, Electronics and Communication Engineering, for his Valuable guidance, encouragement, and continuous Support throughout the duration of this project.

I am also thankful to **Dr.S.P.Yadav**, HOD and Dean Academics, Electronics and Communication Engineering, encouragement, and inspiration.

I would also like to thank the faculty members of the **Electronics and Communication Engineering** and the Lab Technicians for their assistance and cooperation during the practical work of my project.

I am grateful to my friends and well-wishers for their Encouragement, collaboration, and feedback throughout the project journey. Lastly, sincerely thank my parents for their constant support, patience, and motivation, which helped me complete this project successfully.

## REFERENCES

- [1] "What is an Autonomous Car?," Synopsys, Inc. [Online] Available: <https://www.synopsys.com/automotive/what-is-autonomous-car.html>
- [2] "What is an autonomous vehicle? Definition and meaning," Market Business News. [Online] Available: <https://marketbusinessnews.com/financial-glossary/autonomous-vehicle/>.
- [3] "Road traffic injuries," World Health Organization. February 7, 2020. [Online] Available: <https://www.who.int/news-room/fact-sheets/detail/road-traffic-injuries>
- [4] "Traffic Safety Facts," NHTSA. May 2019. [Online] Available: <https://crashstats.nhtsa.dot.gov/Api/Public/ViewPublication/812753>
- [5] "MANAGING A SLOW REACTION TIME," DriveSafety. [Online] December 3, 2018. Available: <https://drivesafety.com/managing-a-slow-reaction-time/>
- [6] A. Jarvis, "An Introduction to Autonomous Cars: How They Will Improve the Cost, Convenience, and Safety of Driving," Velodyne Lidar Inc. September 19, 2018. [Online] Available: [https://velodynelidar.com/blog/an-introduction-to-autonomous-cars-how-they-will-improve-the-cost-convenience-and-safety-of-driving/?utm\\_source=rss&utm\\_medium=rss&utm\\_campaign=an-introduction-to-autonomous-cars-how-they-will-improve-the-cost-convenience-and-safety-of-driving](https://velodynelidar.com/blog/an-introduction-to-autonomous-cars-how-they-will-improve-the-cost-convenience-and-safety-of-driving/?utm_source=rss&utm_medium=rss&utm_campaign=an-introduction-to-autonomous-cars-how-they-will-improve-the-cost-convenience-and-safety-of-driving).
- [7] M. Martínez-Díaz, F. Soriguera, (2018). Autonomous vehicles: theoretical and practical challenges. XIII Conference on Transport Engineering, CIT2018. Available: [www.sciencedirect.com](http://www.sciencedirect.com)

For his expert supervision and helpful suggestions, Which contributed significantly to the successful completion of this project.

I would like to express my profound sense of gratitude to **Dr. K. Venkata Rao, Principal**, for his constant and valuable guidance.

I would like to thank **Dr. Sanjeev Shrivastava, Director**, for his valuable support

I would like to express my deep sense of gratitude to

**Dr. H. S. Saini, Managing Director**, Guru Nanak Group for Testing of Gripper Properties in a Robotic Palletizing

- [8] Intel GO™ Automated Driving Solutions Automated driving, accelerated., Intel, 2016.
- [9] J. Arriola, “Automated and connected driving,” Report of Federal Minister of Transport and Digital Infrastructure. Rep 216, 18-27, 2017.
- [10] S. Shaheen, H. Totte. A. Stocker. “Future of Mobility White Paper,” UC Berkeley, UCConnect. 2018.